

# iBoard®



Scan for  
Installation Video

## iBoard® by APS

PART#: IB-190C&H

READ INSTRUCTIONS CAREFULLY BEFORE STARTING INSTALLATION. REMOVE CONTENTS FROM BOX AND VERIFY ALL PARTS ARE PRESENT. ASSISTANCE IS RECOMMENDED.

\*ROCKER PANEL MOUNT  
\*NO DRILLING REQUIRED

Fastener Size	Tightening Torque (ft-lbs)	Required
6mm	6-7	X
8mm	16-18	✓
10mm	31-32	✓
12mm	56-58	X
14mm	92-94	X

### PART LIST

#### Driver Side Step Bar

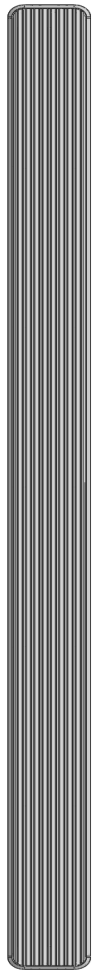

Driver Front Support  
Bracket (DFS)

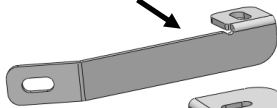

Driver Front Mounting  
Bracket (DFM)

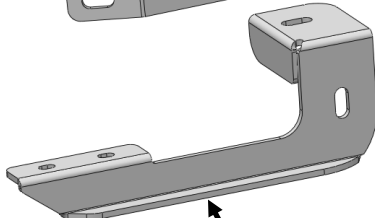

Driver Rear Mounting  
Bracket (DRM)

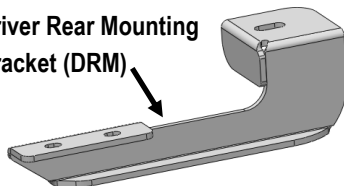

Front



#### Passenger Side Step Bar

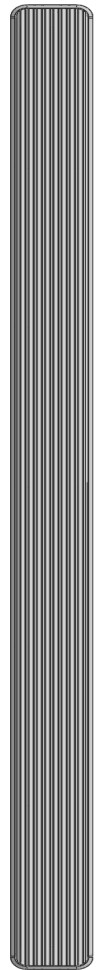

Passenger Front Support  
Bracket (PFS)

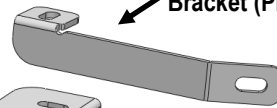

Passenger Front Mounting  
Bracket (PFM)

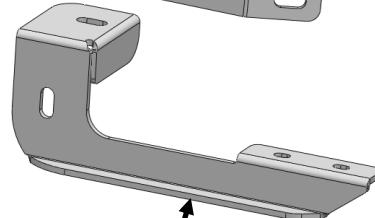

Passenger Rear Mounting  
Bracket (PRM)

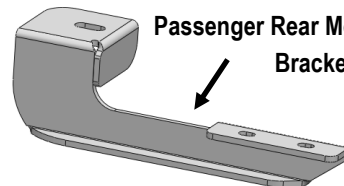

Customer Support: [info@iboardauto.com](mailto:info@iboardauto.com)



## Hardware Package A (For Bracket Installation)

Item	QTY	Description	Item	QTY	Description
1#	2	Rectangular Washers	5#	2	M10X1.5-35mm Hex Bolts
2#	4	M10 T Block Bolts	6#	10	M10 Large Flat Washers
3#	6	M10 Plastic Washers	7#	8	M10 Lock Washers
4#	2	M10X1.5-40mm Carriage Bolts	8#	8	M10 Hex Nuts

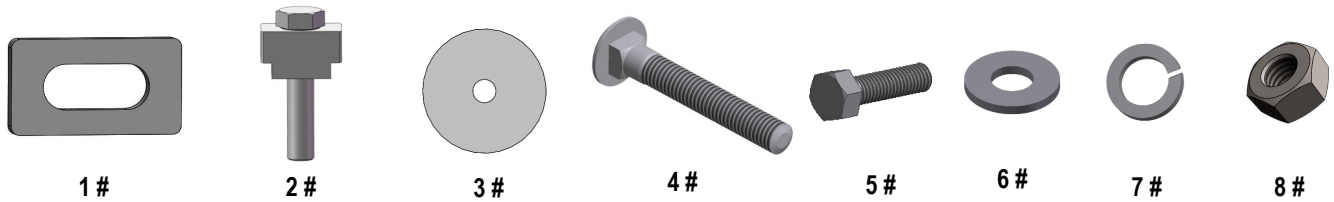

## Hardware Package B (For Stainless Steel Step Bar Installation)

Item	QTY	Description	Item	QTY	Description
1#	8	M8X1.25-35mm Carriage Bolts	3#	8	M8 Nylon Lock Nuts
2#	8	M8 Large Flat Washers	4#	4	Sliders (Packed with Step Bars)

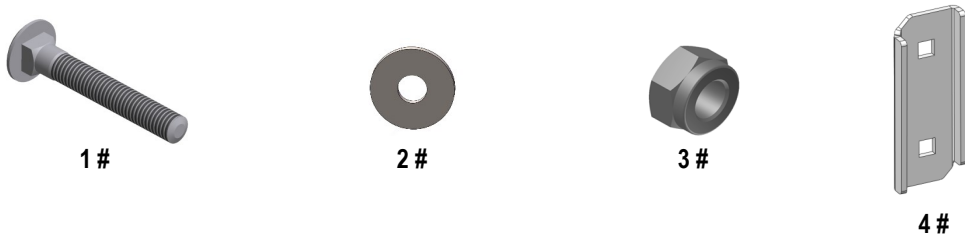



## STEP 1

Start installation from the driver side front of the vehicle. Locate and remove the factory round and oval rubber plugs in the bottom of the body panel located closest to the front tire opening, (Figs 1 & 2).

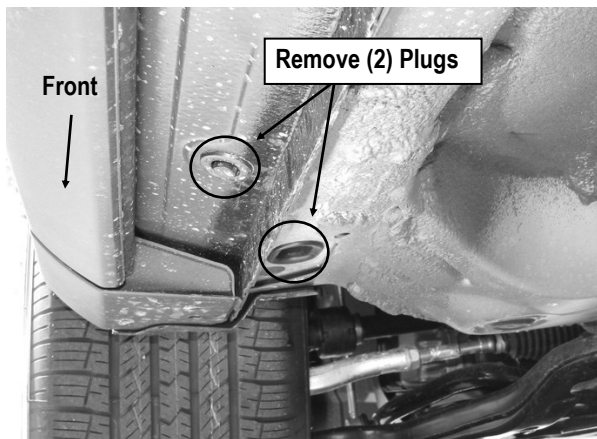

(Fig 1) Driver Side Front Mounting Location

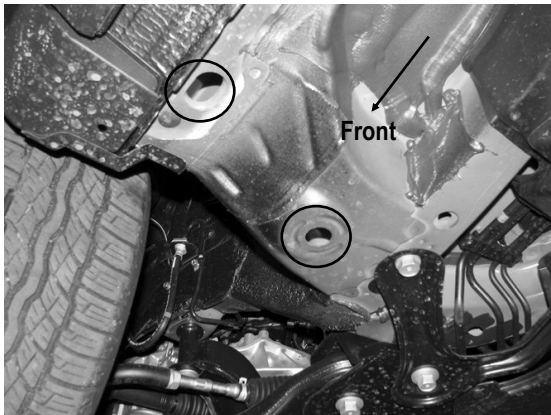

(Fig 2) Driver Side Front Mounting Location

## STEP 2

Select (1) M10X1.5-40mm Carriage Bolt, (1) M10 Rectangular Washer and (1) M10 Plastic Washer, (Fig 3A). Slide the Rectangular Washer onto and over the square shoulder on the Carriage Bolt. Thread the Plastic Washer part way onto the Bolt.

**NOTE:** The Plastic Washer is designed to help hold the Bolt in place during Bracket installation.

Insert the Carriage Bolt with Rectangular Washer and Plastic Washer into the inner round hole in the floor panel. Line up the Carriage Bolt with the center of the hole and the Rectangular Washer across the hole. Pull the Carriage Bolt down through the slot in the Washer. Thread the Plastic Washer down tight against the floor panel, (Fig 3B).

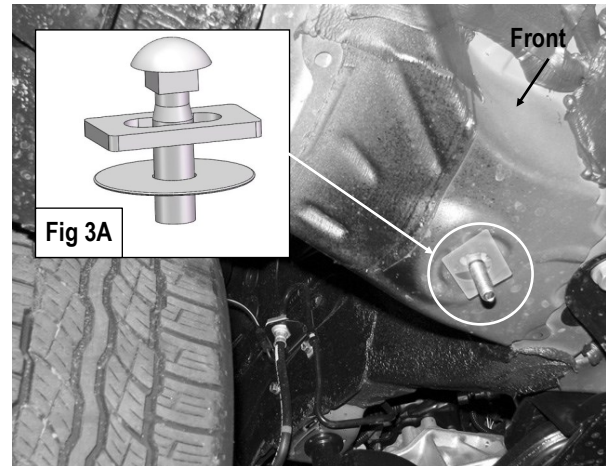

(Fig 3B) Insert M10X1.5-40mm Carriage Bolt

## STEP 3

Select (1) M10 T Block Bolt and (1) M10 Plastic Washer. Insert the M10 T Block Bolt up into the oval hole and rotate it 90-degrees so that the block is across the oval hole. Thread the Plastic Washer onto the T Block Bolt and tight against the floor panel, (Fig 4).

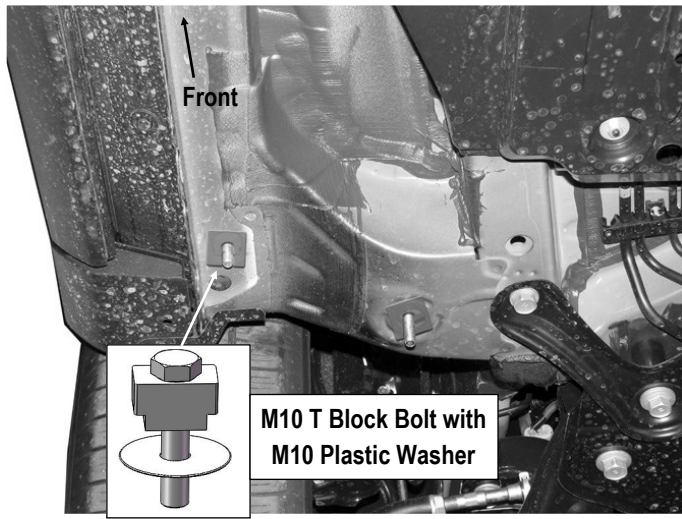

(Fig 4) Insert M10 T Block Bolt

- (1) M10X1.5-40 Carriage Bolt
- (1) M10 Rectangular Washer
- (1) M10 Plastic Washer
- (1) M10 Large Flat Washer
- (1) M10 Lock Washer
- (1) M10 Hex Nut

- (1) M10 T Block Bolt
- (1) M10 Plastic Washer
- (1) M10 Large Flat Washer
- (1) M10 Lock Washer
- (1) M10 Hex Nut

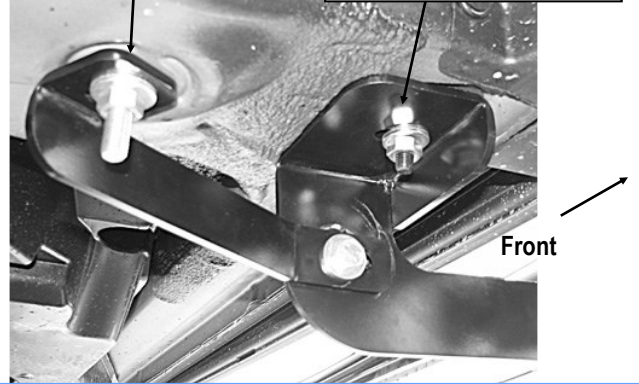

(Fig 6) Driver Side Front Mounting Bracket Installation

## STEP 4

Assemble the Driver Front Support Bracket (DFS) and the Driver Front Mounting Bracket (DFM) with (1) M10X1.5-35mm Hex Bolt, (2) M10 Large Flat Washers, (1) M10 Lock Washer and (1) M10 Hex Nut, (Fig 5). Do not fully tighten at this time.

Next, attach the Driver Front Mounting Bracket (DFM) to the M10 T Block Bolt with (1) M10 Large Flat Washer, (1) M10 Lock Washer and (1) M10 Hex Nut, (Fig 6). Bolt the Support Bracket to the M10X1.5-40mm Carriage Bolt with (1) M10 Large Flat Washer, (1) M10 Lock Washer and (1) M10 Hex Nut, (Fig 6). Do not fully tighten the hardware at this time.

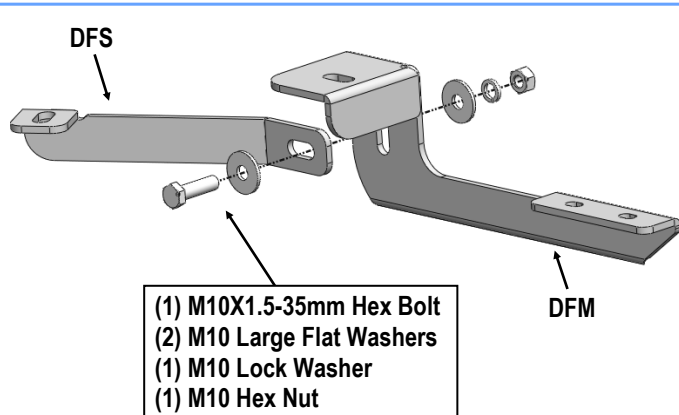

(Fig 5) Driver Side Front Brackets Assembly

## STEP 5

Move to the rear mounting location, (Fig 7). Remove the oval rubber plug. Select (1) M10 T Block Bolt and (1) M10 Plastic Washer. Insert the M10 T Block Bolt up into the oval hole and rotate 90-degrees so that the block is across the oval hole. Thread the Plastic Washer onto the T Block Bolt and tight against the floor panel as described in Step 2, (Fig 8).

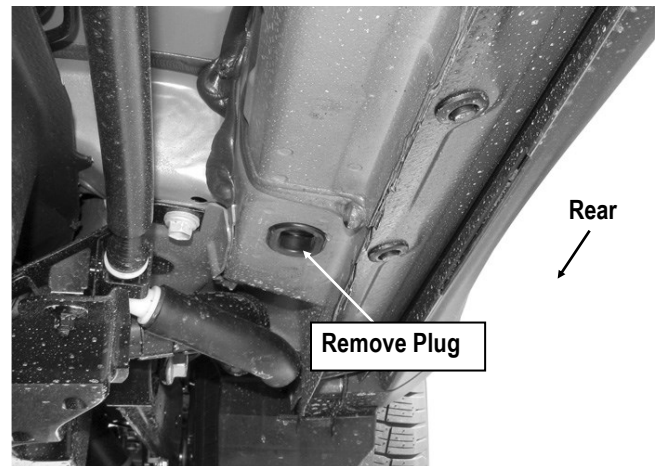

(Fig 7) Driver Side Rear Mounting Location

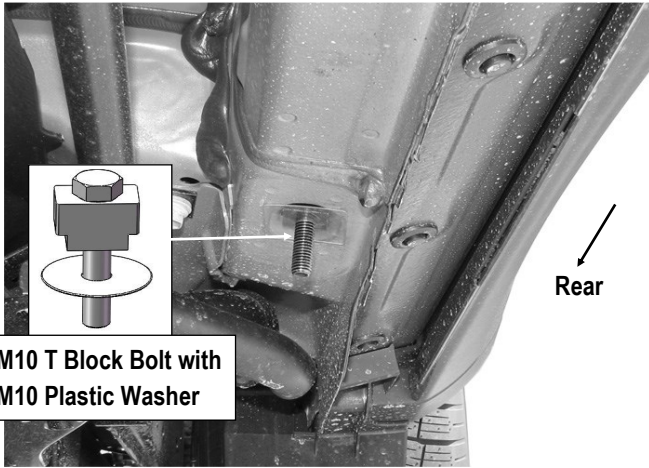

M10 T Block Bolt with  
M10 Plastic Washer

(Fig 8) Driver Side Rear Mounting Location

## STEP 6

Select the Driver Rear Mounting Bracket (**DRM**). Hang the Rear Bracket from the M10 T Block Bolt with (1) M10 Large Flat Washer, (1) M10 Lock Washer and (1) M10 Hex Nut, (**Fig 9**). Do not fully tighten the hardware at this time.



(1) M10 T Block Bolt  
(1) M10 Plastic Washer  
(1) M10 Large Flat Washer  
(1) M10 Lock Washer  
(1) M10 Hex Nut

(Fig 9) Driver Side Rear Mounting Bracket Installation

## STEP 7

Once all (2) Driver side mounting brackets are installed, then proceed to the Step Bar installation. (**Figs 10 & 11**)

- (1) Select (1) Slider and (2) M8X1.25-35mm Carriage Bolts;
- (2) Install (2) M8X1.25-35mm Carriage Bolts in (1) Slider.
- (3) Slide the Slider (with carriage bolts) to the **Step Bar**.
- (4) Repeat to install the other (1) slider to the step bar.
- (5) Attach the Step Bar (with the Sliders) onto the installed mounting brackets. Position the Sliders to the installed brackets. Secure the Step Bar to the installed Brackets by using (4) M8 Large Flat Washers and (4) M8 Nylon Lock Nuts and (2) Sliders, (**Fig 11**). Do not fully tighten hardware at this time.

**Note:** The Sliders are packed with the Step Bars.

Level and adjust the Step Bar and fully tighten all hardware. Repeat **Steps 1-7** for the other side Step Bar installation. **The installation is completed!!!**

### Attention

Do periodic inspections to the installation to make sure that all hardware is secure and tight.

In order to protect your bars/boards, please use mild soap/non-abrasive products for cleaning only.

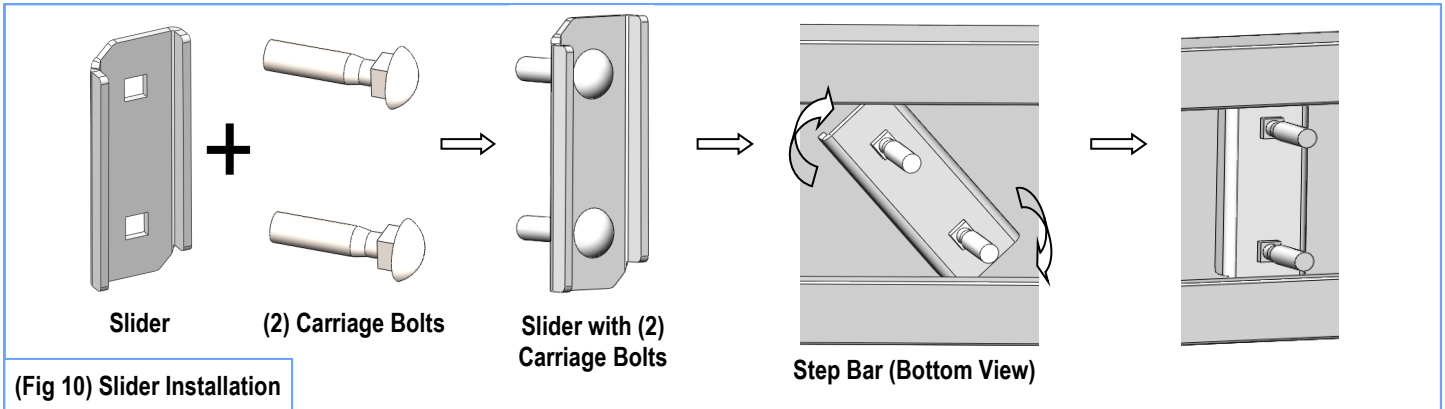

(Fig 10) Slider Installation

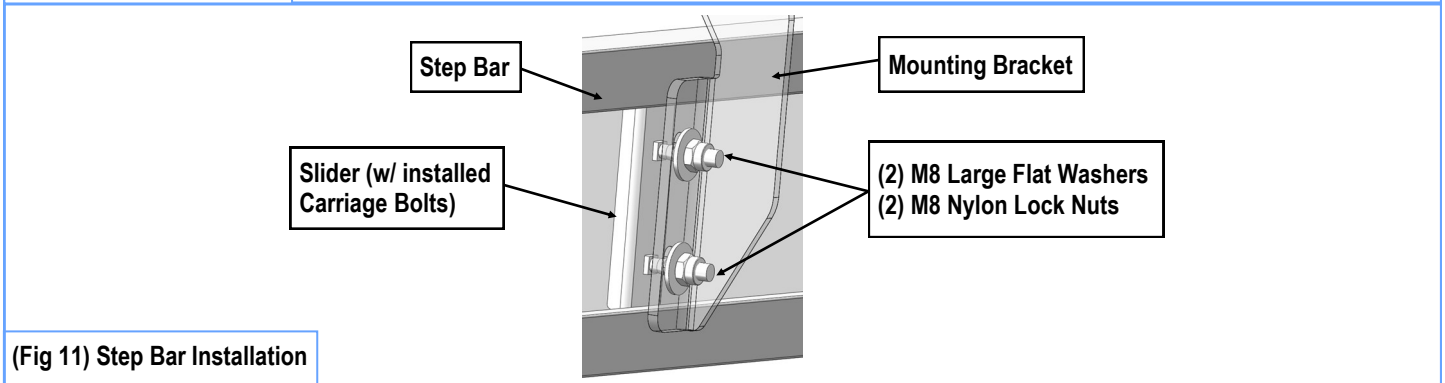

(Fig 11) Step Bar Installation