

iBoard®



Scan for
Installation Video

iBoard® by APS

PART#: IB-095L C&H

READ INSTRUCTIONS CAREFULLY BEFORE STARTING INSTALLATION. REMOVE CONTENTS FROM BOX AND VERIFY ALL PARTS ARE PRESENT. ASSISTANCE IS RECOMMENDED.

*ROCKER PANEL MOUNT
*NO DRILLING REQUIRED

Fastener Size	Tightening Torque (ft-lbs)	Required
6mm	6-7	X
8mm	16-18	√
10mm	31-32	√
12mm	56-58	X
14mm	92-94	X

PART LIST

Driver Side Step Bar

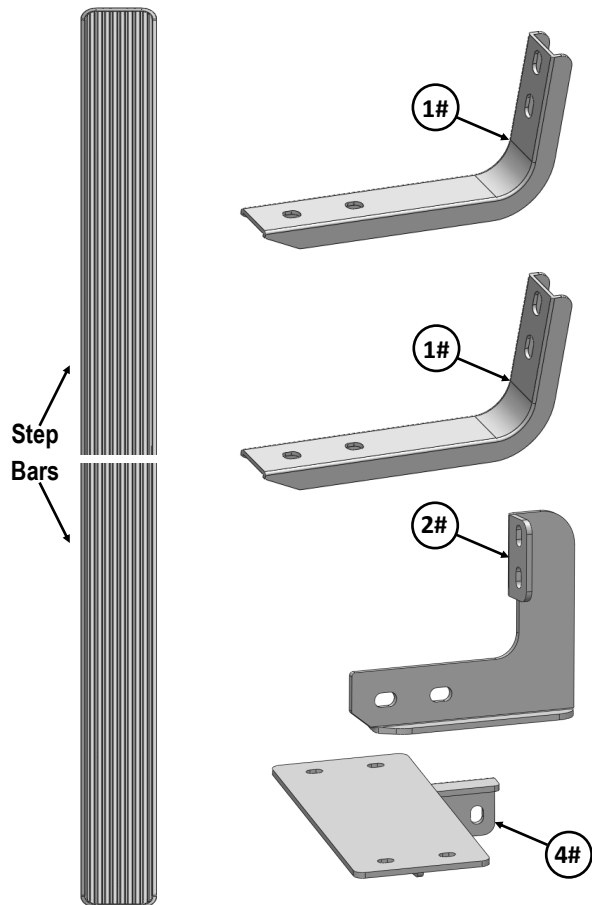

Front



Passenger Side Step Bar

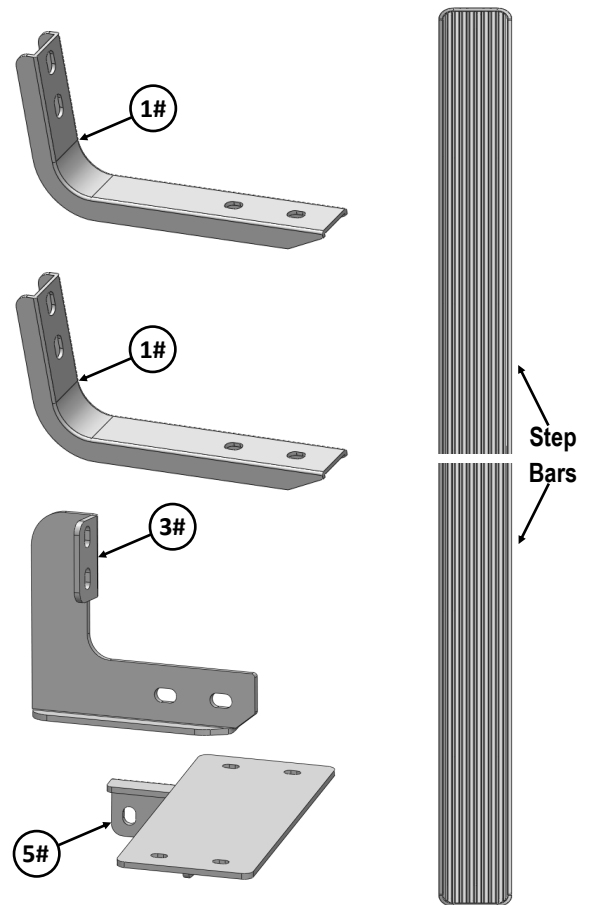



Customer Support: info@iboardauto.com





Mounting Bracket List					
Item	QTY	Description	Item	QTY	Description
1#	4	Mounting Brackets	4#	1	Driver Rear Bar Bracket
2#	1	Driver Rear Mounting Bracket	5#	1	Passenger Rear Bar Bracket
3#	1	Passenger Rear Mounting Bracket			

Hardware Package A (For Bracket Installation)					
Item	QTY	Description	Item	QTY	Description
1#	12	M8 Flat Washers	5#	8	M10 Flat Washers
2#	12	M8 Lock Washers	6#	4	M10 Lock Washers
3#	12	M8 Hex Nuts	7#	4	M10 Hex Nuts
4#	4	M10X1.5-30mm Hex Bolts			

 1 #

 2 #

 3 #

 4 #

 5 #

 6 #

 7 #

Hardware Package B (For Stainless Steel Step Bar Installation)					
Item	QTY	Description	Item	QTY	Description
1#	16	M8X1.25-35mm Carriage Bolts	3#	16	M8 Nylon Lock Nuts
2#	16	M8 Large Flat Washers	4#	8	Sliders (Packed with Step Bars)

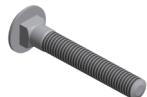
 1 #

 2 #

 3 #

 4 #

Hardware Package C (For Stainless Steel Step Bar Assembly)					
Item	QTY	Description	Item	QTY	Description
1#	8	Plastic Rivets	5#	4	M8 Hex Nuts
2#	12	M8X1.25-25mm Inner Hex Bolts	6#	2	Plastic Covers (Packed with Step Bars)
3#	16	M8 Flat Washers	7#	2	Back Plates (Packed with Step Bars)
4#	12	M8 Lock Washers			

 1 #

 2 #

 3 #

 4 #

 5 #

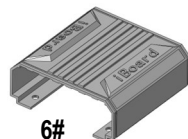
 6 #

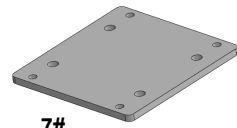
 7 #



STEP 1

Step Bar Assembly:

1. Select and assemble (2) Step Bars with (2) M8X1.25-25mm Inner Hex Bolts, (4) M8 Flat Washers, (2) M8 Lock Washers and (2) M8 Hex Nuts, (**Fig 1**). **NOTE: (4) Step Bars are universal.**
2. Attach (1) Back Plate to the bottom of the installed (2) Step Bars with (4) M8X1.25-25mm Inner Hex Bolts, (4) M8 Flat Washers, (4) M8 Lock Washers, (**Fig 2**).
3. Install (1) Plastic Cover to cover the joint of (2) Step bars with (4) Plastic Rivets, (**Fig 3**).
4. Repeat to assemble the other (2) Step Bars.

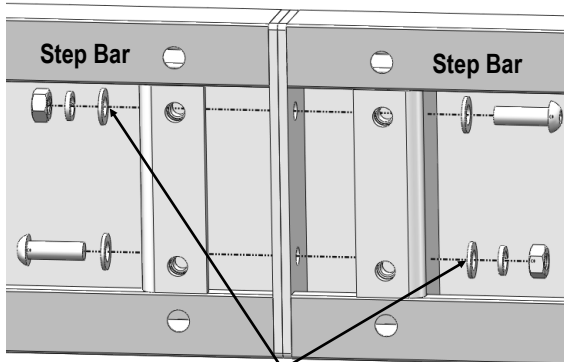

(2) M8X1.25-25mm Inner Hex Bolts
(4) M8 Flat Washers
(2) M8 Lock Washers
(2) M8 Hex Nuts

(Fig 1) Step Bars Assembly

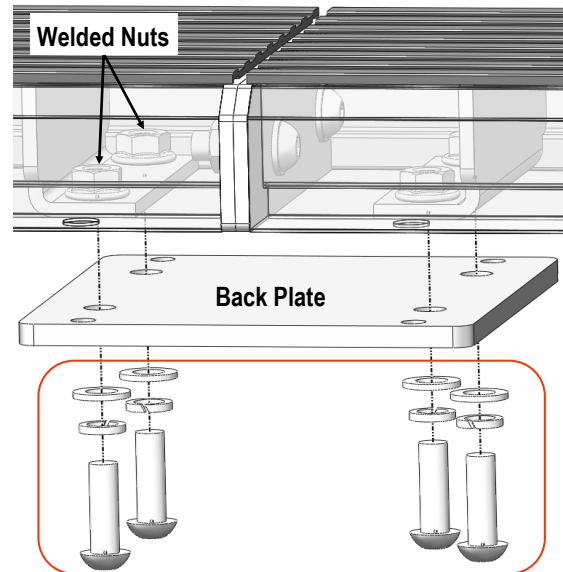

(4) M8X1.25-25mm Inner Hex Bolts
(4) M8 Flat Washers
(4) M8 Lock Washers

(Fig 2) Back Plate Installation

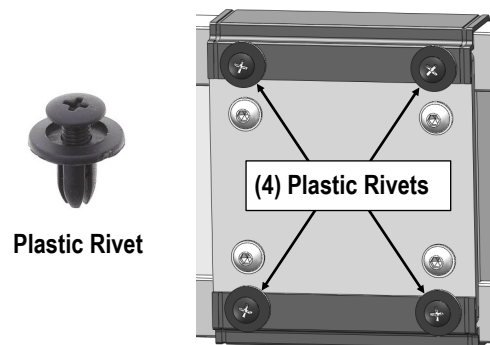

Plastic Rivet

(Fig 3) Plastic Cover Installation
(Bottom View)

Assembled Step Bars





STEP 2

Start installation from the Passenger Side Front Mounting Location.

Vehicle equipped existing factory running board:

- 1) Remove the existing running board by removing the (6) nuts mounting the brackets to inside of body panel.
- 2) Install (1) Mounting Bracket with (2) removed factory nuts, leave nuts loose at this time (**Fig 4**).

Vehicle without existing factory running board:

Secure (1) Mounting Bracket to the body panel with the supplied (2) M8 Hex Nuts, (2) M8 Large Flat Washers & (2) M8 Lock Washers (**Fig 5**). Do not fully tighten at this time.

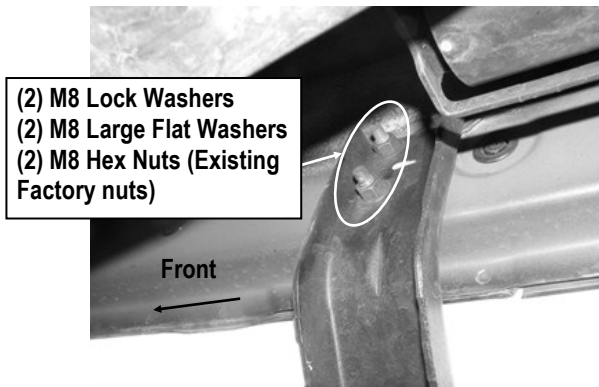

(Fig 4) Passenger Front Mounting Bracket Installed
(Vehicle equipped existing factory running board)

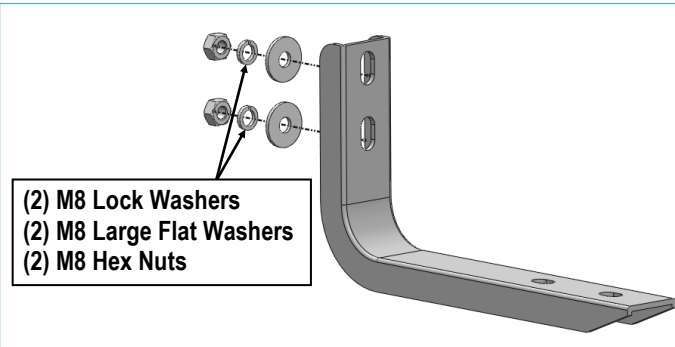

(Fig 5) Passenger Front Mounting Bracket Installed
(Vehicle without existing factory running board)

STEP 3

Repeat **Step 2** to install the other passenger side mounting bracket. Don't fully tighten the hardware at this time.

STEP 4

Move to the passenger side rear of the vehicle. Assemble (1) Passenger Rear Mounting Bracket and (1) Passenger Rear Bar Bracket with (2) M10X1.5-30mm Hex Bolts, (2) M10 Lock Washers, (4) M10 Flat Washers and (2) M10 Hex Nuts, (**Fig 6**). Do not fully tighten hardware at this time.

Repeat **Steps 2-3** to install the assembled Passenger Rear Mounting Brackets.

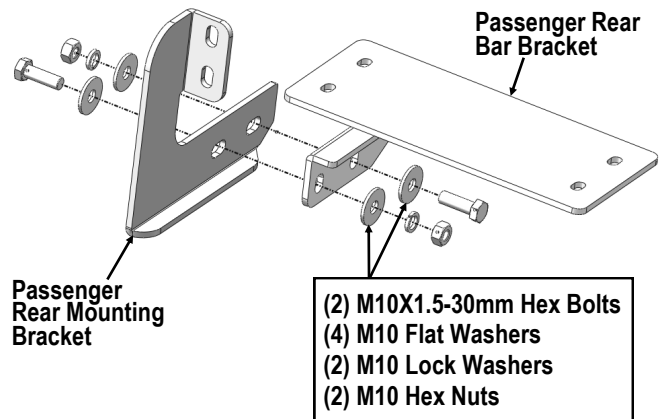

(Fig 6) Passenger Rear Brackets Assembly

STEP 5

Once all (3) Passenger side mounting brackets are installed, then proceed to the Step Bar installation. (**Figs 7 & 8**)

- (1) Select (1) Slider and (2) M8X1.25-35mm Carriage Bolts;
- (2) Install (2) M8X1.25-35mm Carriage Bolts in (1) Slider.
- (3) Slide the Slider (with carriage bolts) to the **Step Bar**.
- (4) Repeat to install the other (2) sliders to the step bar.
- (5) Attach the Step Bar (with the Sliders) onto the installed mounting brackets. Position the Sliders to the installed back-



ets. Secure the Step Bar to the installed Brackets by using (8) M8 Large Flat Washers and (8) M8 Nylon Lock Nuts and (4) Sliders, **(Fig 8)**. Do not fully tighten hardware at this time.

Note: The Sliders are packed with the Step Bars.

Level and adjust the Step Bar and fully tighten all hardware.

Repeat **Steps 2-5** for the other side Step Bar installation. **The installation is completed!!!**

Attention

Do periodic inspections to the installation to make sure that all hardware is secure and tight.

In order to protect your bars/boards, please use mild soap/non-abrasive products for cleaning only.

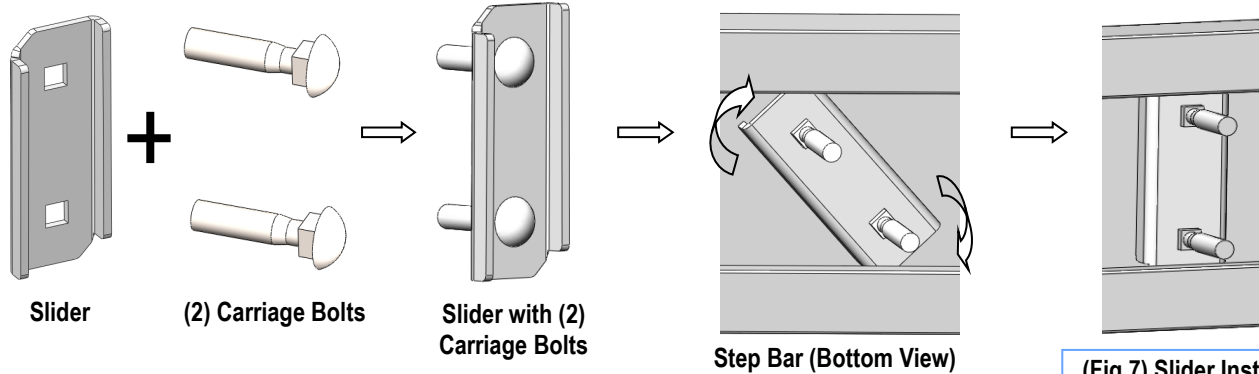

(Fig 7) Slider Installation

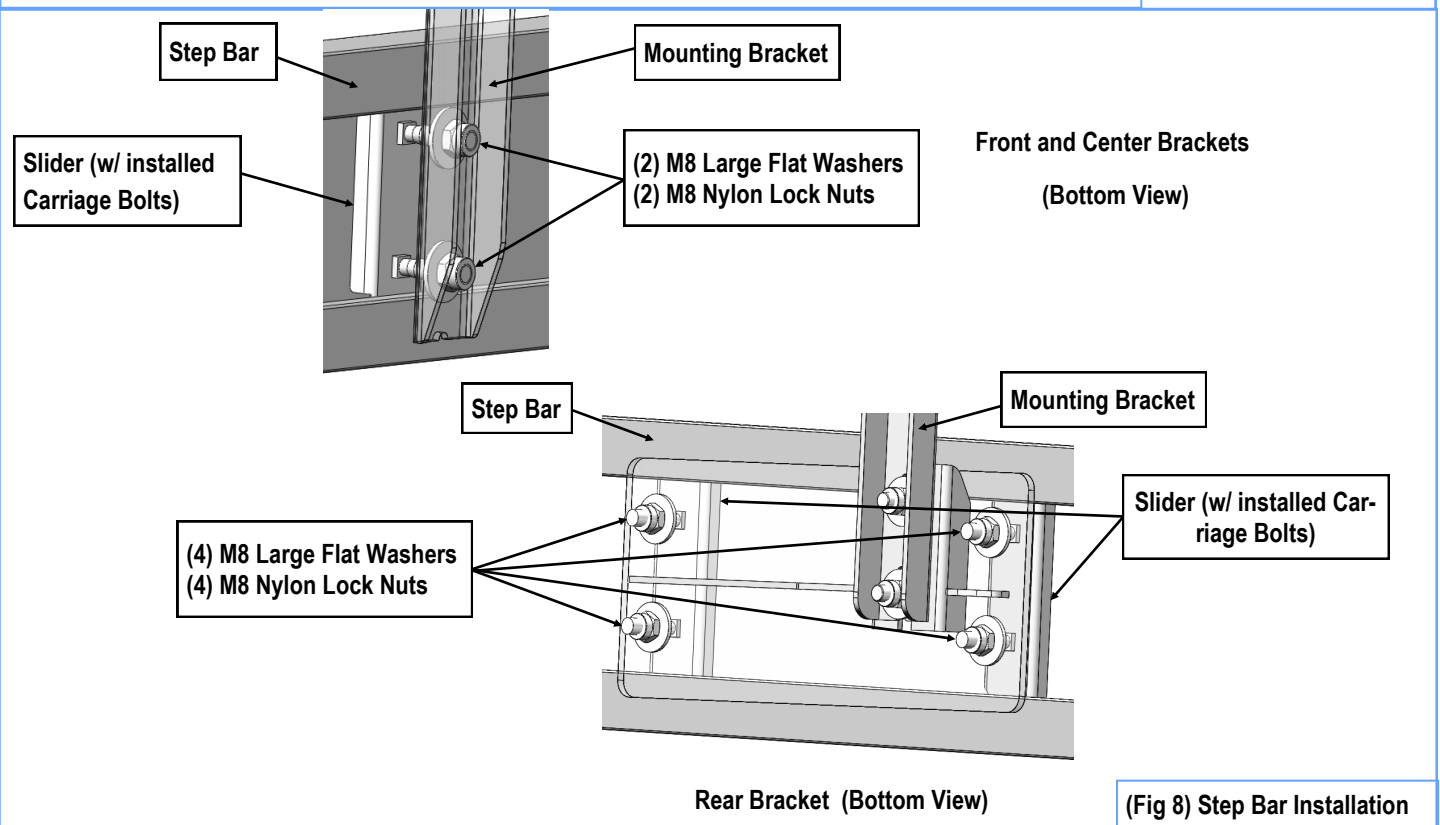

(Fig 8) Step Bar Installation