

# iBoard®

## iBoard® by APS

PART#: IB-R094/R095/R952

READ INSTRUCTIONS CAREFULLY BEFORE STARTING INSTALLATION. REMOVE CONTENTS FROM BOX AND VERIFY ALL PARTS ARE PRESENT. ASSISTANCE IS RECOMMENDED.

\*ROCKER PANEL MOUNT  
\*NO DRILLING REQUIRED

Fastener Size	Tightening Torque (ft-lbs)	Required
6mm	6-7	√
8mm	16-18	√
10mm	31-32	X
12mm	56-58	X
14mm	92-94	X

Item	QTY	Description	Item	QTY	Description
1#	6	Mounting Brackets	4#	12	M6 Large Flat Washers
2#	12	M8 Hex Flange Nuts	5#	12	M6 Nylon Lock Nuts
3#	12	M6X1-20mm Square Head Bolts			

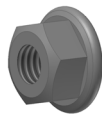

2 #

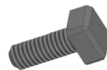

3 #



4 #



5 #

# iBoard®

Driver

Front



Passenger

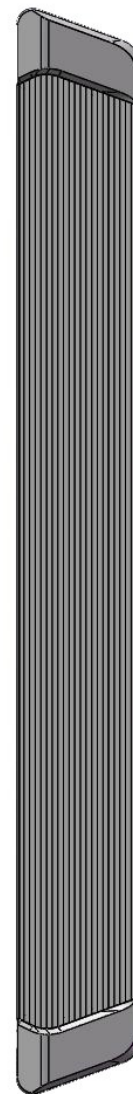
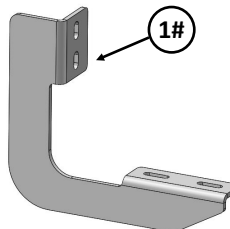
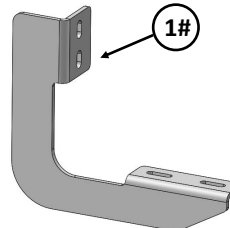
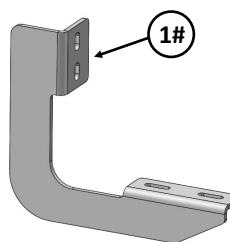
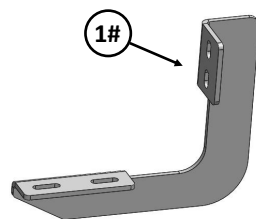
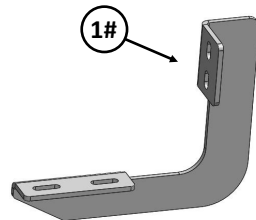
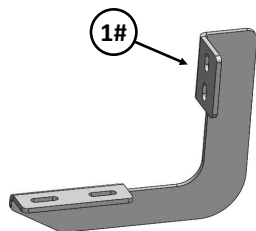

# iBoard®

## STEP 1

Start installation on the driver side of the vehicle. Locate the driver side front bracket mounting location. Select (1) Mounting Bracket, install with (2) M8 Hex Flange Nuts. Do not fully tighten hardware at this time.

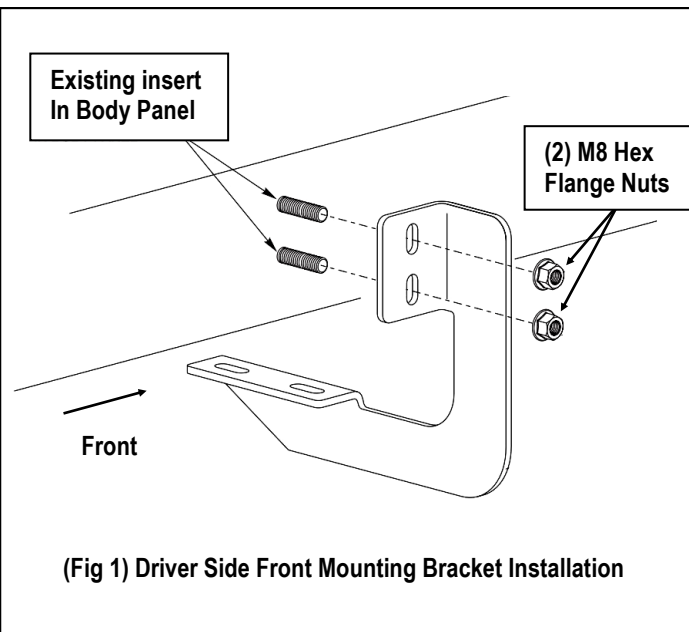

## STEP 2

Move to the Driver Side Center & Rear Mounting location. Repeat **Step 1** to install the Driver Side Center & Rear Mounting Bracket.

**Note:** (6) Mounting Brackets are universal.

## STEP 3

Select a Running Board. Slip (3) M6x1-20mm Square Head Bolts into each bottom channel (**Fig 2**). Carefully position the Running Board onto the (3) Mounting Brackets.

**IMPORTANT:** Do not slide the Running Board on the Brackets or the bottom surface of the board will be damaged. Attach the Running Board to each Mounting Bracket with (2) M6x1-20mm Square Head Bolts, (2) M6 Large Flat Washers and (2) M6 Nylon Lock Nuts (**Fig 3**). Do not fully tighten at this time.

M6X1-20mm Square Head Bolts

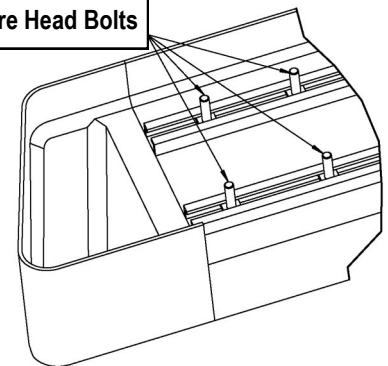

(Fig 2) Slip M6X1-20mm Square Head Bolts Into The Bottom Channels

(2) M6X1-20mm Square Head Bolts  
(2) M6 Large Flat Washers  
(2) M6 Nylon Lock Nuts

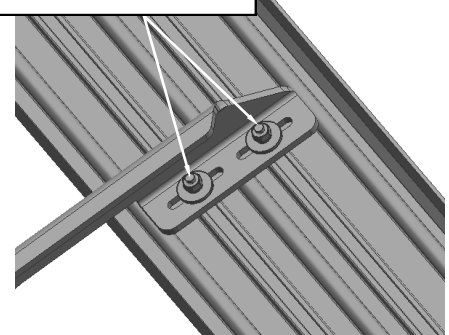

(Fig 3) Running Board Installed Onto Mounting Bracket

# iBoard®

## STEP 4

Level and adjust the Running Board and fully tighten all hardware.

**Important:** Please follow the recommended Tightening Torques shown in the table on page 1. Don't over tighten, or the nuts/bolts will be damaged.

## STEP 5

Repeat **Steps 1-4** for the other side Running Board installation. The installation is completed .

### Attention

Do periodic inspections to the installation to make sure that all hardware is secure and tight.

In order to protect your bars/boards, please use only mild soap/non-abrasive products for cleaning.