

iBoard®

iBoard® by APS

PART#: IB-R269

READ INSTRUCTIONS CAREFULLY BEFORE STARTING INSTALLATION. REMOVE CONTENTS FROM BOX AND VERIFY ALL PARTS ARE PRESENT. ASSISTANCE IS RECOMMENDED.

*BODY FRAME MOUNT

*DRILLING IS REQUIRED/ CUTTING IS REQUIRED

Fastener Size	Tightening Torque (ft-lbs)	Required
6mm	6-7	√
8mm	16-18	√
10mm	31-32	X
12mm	56-58	X
14mm	92-94	X

PART LIST

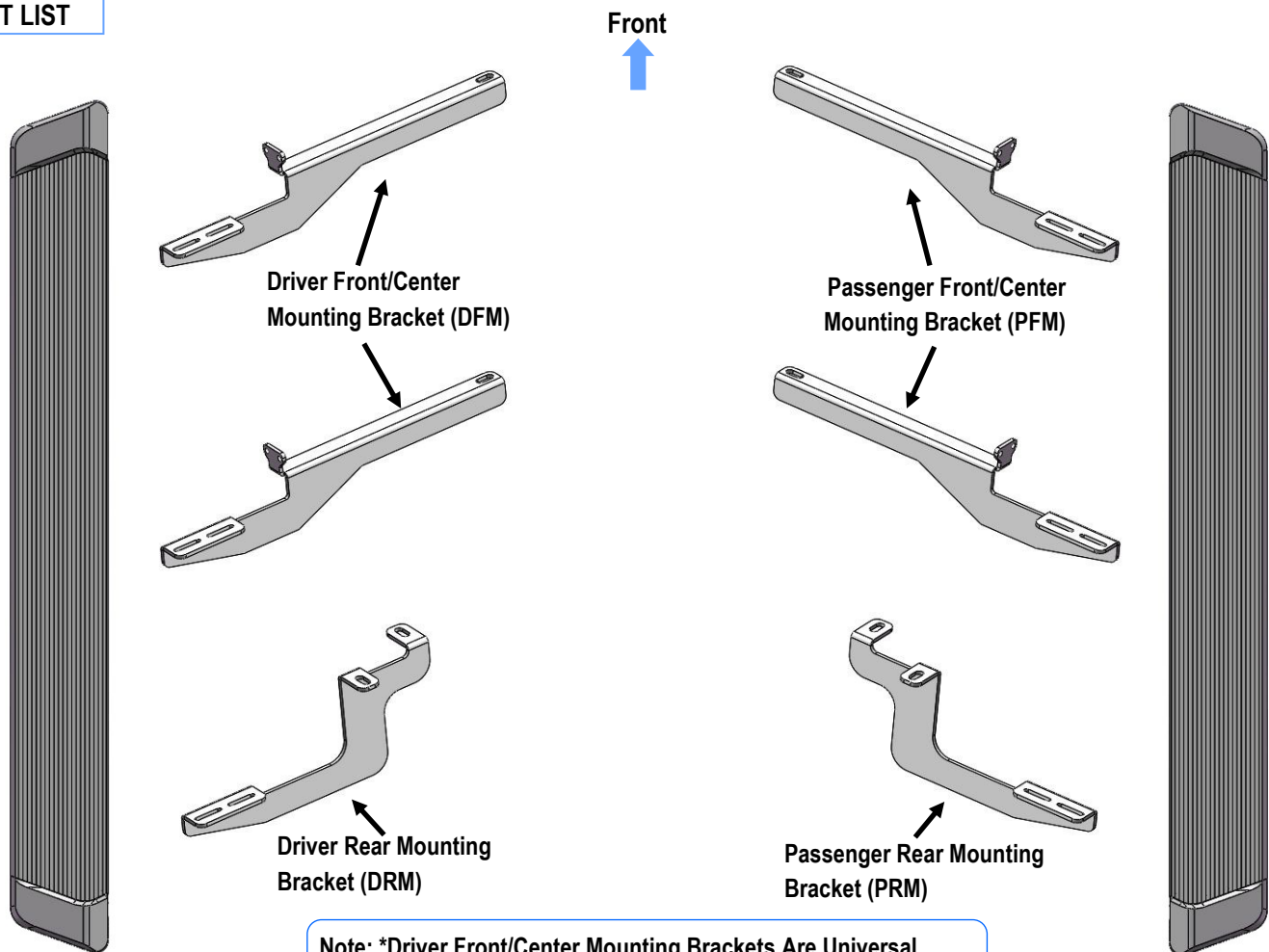

Note: *Driver Front/Center Mounting Brackets Are Universal
*Passenger Front/Center Mounting Brackets Are Universal

Customer Support: info@iboardauto.com

iBoard®

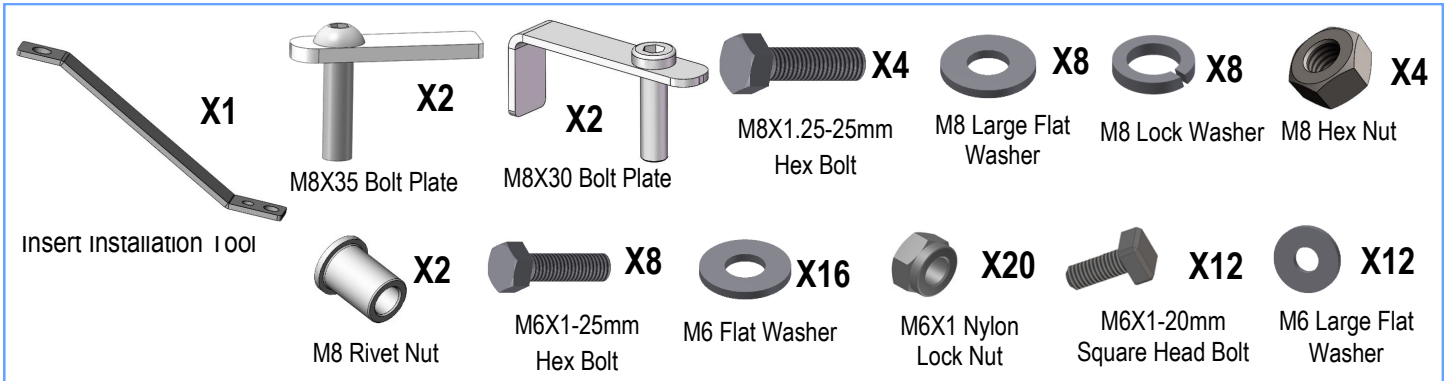

STEP 1

Start installation from the passenger side front of the vehicle. Remove the plastic rocker panel cover running from wheel opening to wheel opening, (Fig 1). **NOTE:** Removal of the rocker panel cover is not mandatory but it is highly recommended.

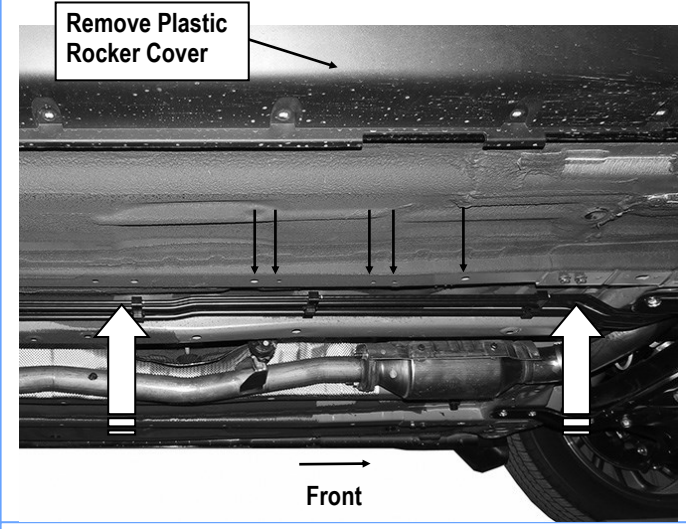

(Fig 1) Passenger Side Front Mounting Location Pictured

STEP 2

Locate the (2) factory hex bolts in the bottom of the inner frame channel, (Fig 2). Remove **only** the rear hex bolt if equipped, (Fig 2). Do not remove the front hex bolt.

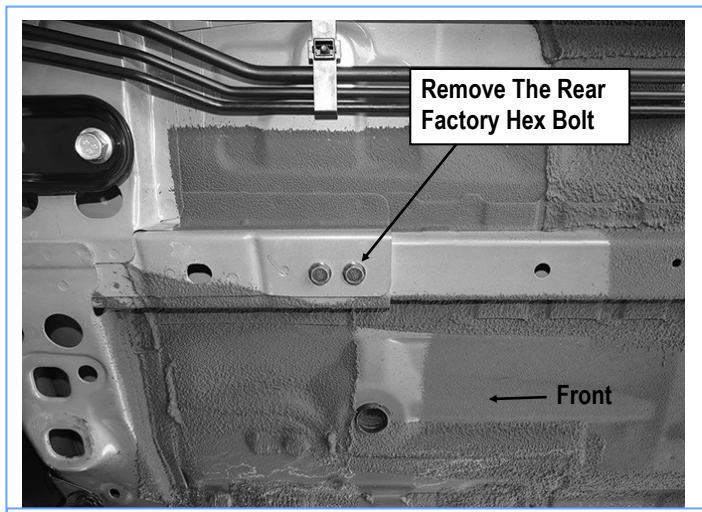

(Fig 2) Passenger Side Front Mounting Location Pictured

STEP 3

Select (1) Passenger Front Mounting Bracket (PFM). **NOTE:** When properly installed, the mounting cradles on all (3) Brackets will point toward the rear of the vehicle.

Attach the inner end of the Bracket to the frame channel with (1) M8X1.25-25mm Hex Bolts, (1) M8 Lock Washer and (1) M8 Large Flat Washer, (Fig 3). Do not fully tighten hardware at this time.

Line up the tab on the Bracket with the outside of the pinch weld. Use a clamp to temporarily attach the tab on the Bracket to the pinch weld.

iBoard®

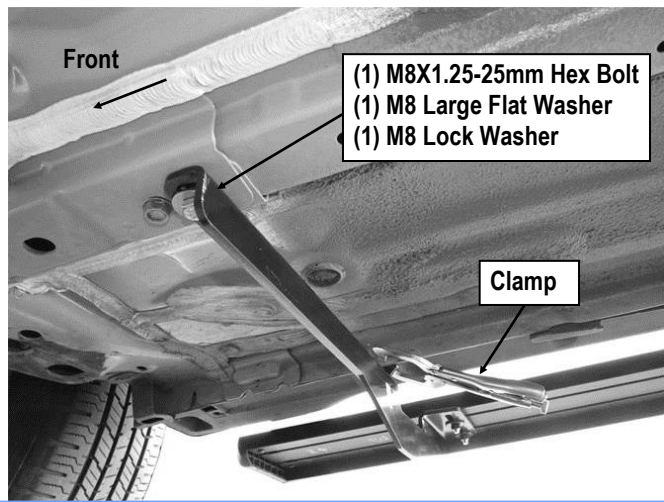

(Fig 3) Passenger Front Mounting Bracket Installation

STEP 4

Move to the rear of the vehicle. Locate the factory holes in the bottom of the floor panel behind the jack point on the pinch weld directly in front of the rear suspension mount, (Fig 4).

Insert (1) M8X35 Bolt Plate into the round hole in the inner floor panel, (Fig 5). Insert (1) M8X30 Bolt Plate into the oval hole. Feed the threaded end of the M8X30 Bolt Plate into and out of the smaller outer hole, (Fig 5). **NOTE:** Hold the passenger side Rear Bracket up in place to help determine the correct mounting holes for the Bracket.

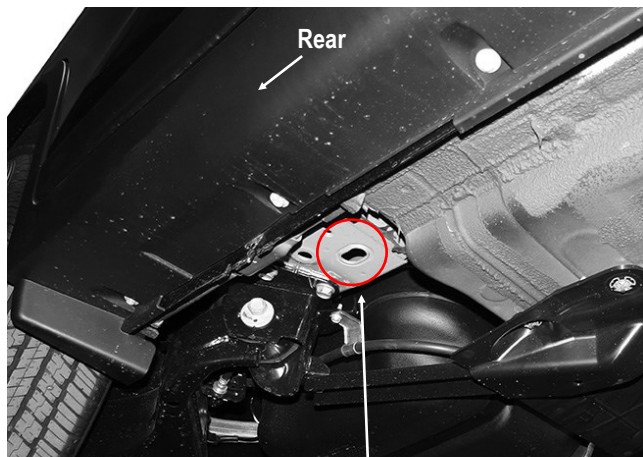

(Fig 4) Passenger Side Rear Mounting Location Pictured

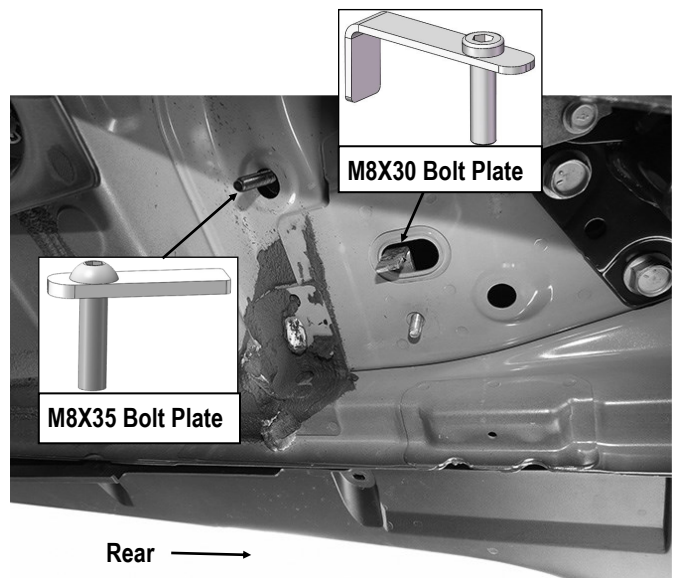

(Fig 5) Insert M8X35 Bolt Plate & M8X30 Bolt Plate

STEP 5

Select the Passenger Rear Mounting Bracket (PRM). Attach the Bracket to the (2) Installed Bolt Plates with (2) M8 Large Flat Washers, (2) M8 Lock Washers and (2) M8 Hex Nuts, (Fig 6). Do not fully tighten hardware at this time.

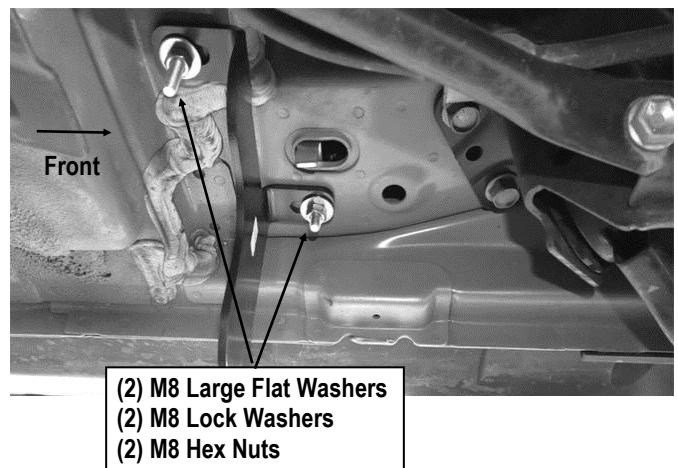

(Fig 6) Passenger Rear Mounting Bracket Installation

iBoard®

STEP 6

Select a Running Board. Slip (3) M6X1-20mm Square Head Bolts into each bottom channel (**Fig 7**). Carefully position the Running Board onto the (3) Mounting Brackets.

IMPORTANT: Do not slide the Running Board on the Brackets or the bottom surface of the board will be damaged. Attach the Running Board to each Mounting Bracket with (2) M6x1-20mm Square Head Bolts, (2) M6 Large Flat Washers and (2) M6 X1 Nylon Lock Nuts (**Fig 8**). Do not fully tighten at this time.

M6X1-20mm Square Head Bolts

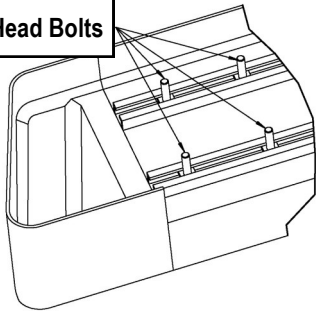

(Fig 7) Slip M6X1-20mm Square Head Bolts Into The Bottom Channels

(2) M6X1-20mm Square Head Bolts
(2) M6 Large Flat Washers
(2) M6X1 Nylon Lock Nuts

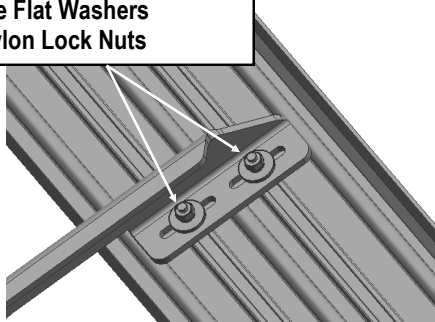

(Fig 8) Running Board Installed Onto the Mounting Bracket

STEP 7

Line up the Running Board with the front and rear of the vehicle. Once properly aligned, tighten the hardware and clamp attaching the front and rear mounting Brackets to the vehicle only.

STEP 8

Move to the center of the vehicle. Locate the holes in the bottom of the inner frame channel, (**Fig 1**). Locate the 6th hole back from the front bracket mounting location. **IMPORTANT:** Mark the correct mounting hole before moving to **Step 9**, (**Fig 9**).

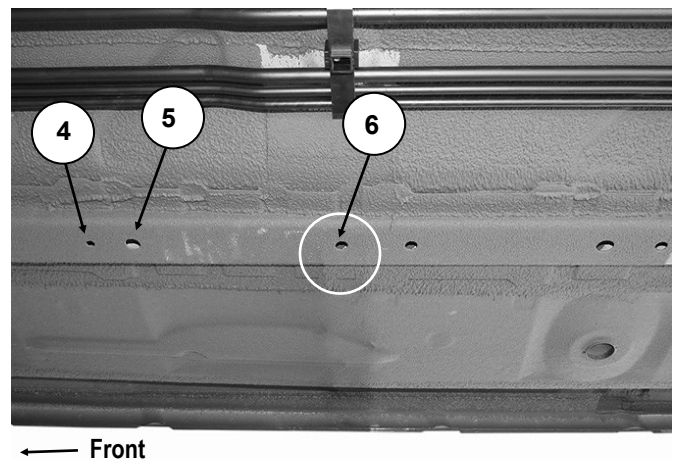

(Fig 9) Passenger Side Center Mounting Location Pictured

STEP 9

Select (1) M8X1.25-25mm Hex Bolts, (1) M8 Large Flat Washer, (1) Insert Installation Tool and (1) M8 Rivet Nut. Assemble the tool as pictured in (**Fig 10**). **NOTE: Select 8mm hole on Threaded Insert Tool (Fig 11).** Hold the Tool assembly and push the threaded Insert into the correct hole in the frame channel identified in **Step 8**, (**Fig 1 & 9**).

IMPORTANT: M8 Rivet Nut cannot be removed once installed. Verify that M8 Rivet Nut is in the correct hole in the frame channel before proceeding.

iBoard®

STEP 11

Select (1) Passenger Center Mounting Bracket (**PFM**). Bolt the inner end of the center Bracket to the M8 Rivet Nut with (1) M8X1.25-25mm Hex Bolts, (1) M8 Lock Washer and (1) M8 Large Flat Washer, (**Fig 13**). Do not fully tighten hardware at this time.

Use a clamp to temporarily attach the outer end of the Bracket to the pinch weld to help hold up the Bracket as described in **Step 3**, (**Fig 13**).

(1) M8X1.25-25mm Hex Bolt
(1) M8 Large Flat Washer
(1) M8 Lock Washer

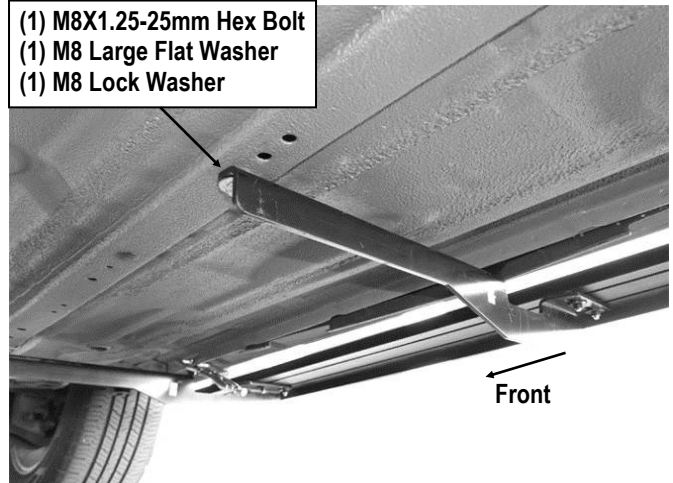

(Fig 13) Passenger Center Mounting Bracket Installation

STEP 12

Level and adjust the Running Board to the vehicle.

Once properly adjusted, mark the location of the front, (**Fig 14**), and center, (**Fig 15**), mounting tabs onto the outside of the pinch weld.

IMPORTANT: Adjust the Running Board height, (push upward), so that when level, the holes in the mounting tabs are not too close to the bottom edge of the pinch weld.

(1) M8X1.25-25mm Hex Bolt
(1) M8 Large Flat Washer
(1) Insert Installation Tool
(1) M8 Rivet Nut



Fig 10

8mm Threaded Hole



Fig 11

STEP 10

Hold the Insert in place by firmly grasping the handle on the Tool. Turn the M8 Hex Bolt, (tighten), with wrench to expand the M8 Rivet Nut in the hole in the frame channel, (**Fig 12**). Once the M8 Rivet Nut is fully compressed/ expanded, remove the Hex Bolt and Tool from the Rivet Nut. **WARNING:** Do not over-tighten the Rivet Nut or damage to the part or Rivet Nut may result.

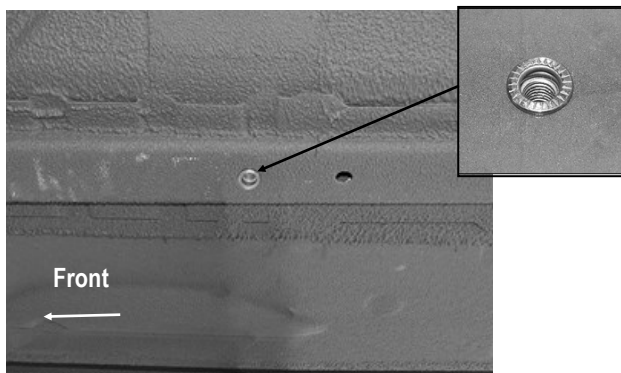

(Fig 12) Insert The M8 Rivet Nut

iBoard®

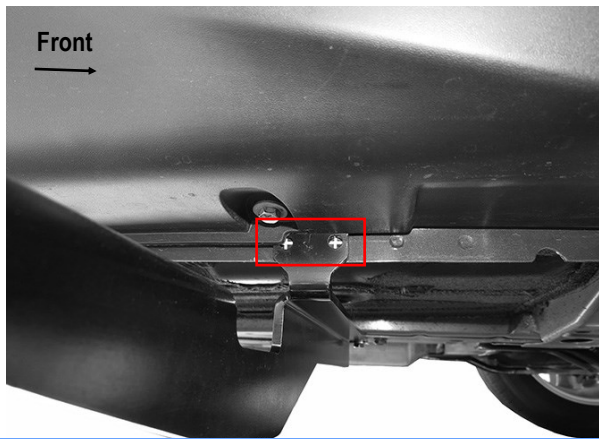

(Fig 14) Passenger Front Bracket Location Marked Before Drilling

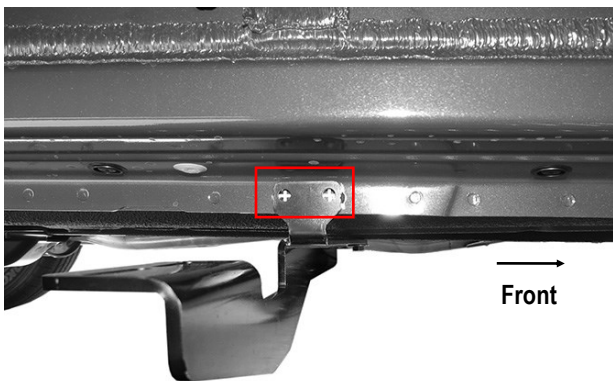

(Fig 15) Passenger Center Bracket Location Marked Before Drilling (Rocker Panel Cover Removed)

STEP 13

Remove the Running Board and loosen or remove the Passenger Front & Center Mounting Brackets (**PFM**). Use a 1/4" drill bit to drill out the (4) holes in the pinch weld for the Passenger Front & Center Mounting Brackets (**PFM**).

IMPORTANT! Any cutting or drilling tool may break or shatter. Government regulations require safety glasses & equipment at all times when cutting or drilling.

STEP 14

Reinstall the Passenger Front Mounting Bracket (**PFM/PCM**) as previously described. Attach the outer end of the Bracket to the outside of the pinch weld with (2) M6X1-25mm Hex Bolts, (4) M6 Flat Washers and (2) M6X1 Nylon Lock Nuts, (**Fig 16**). Do not fully tighten hardware at this time.

Repeat to reinstall the Passenger Center Mounting Bracket (**PFM**), (**Fig 17**).

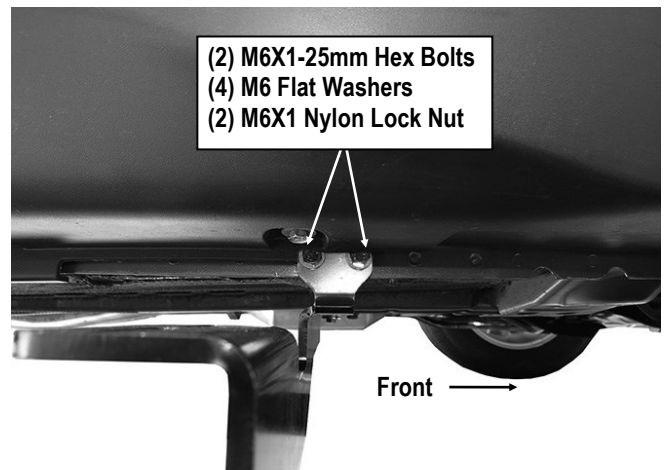

(Fig 16) Passenger Front Mounting Bracket Installation

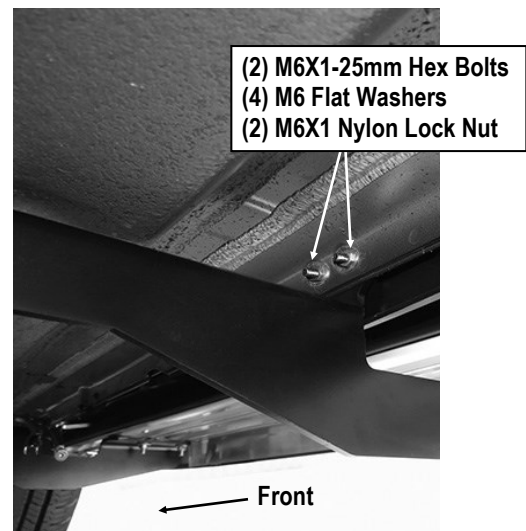

(Fig 17) Passenger Center Mounting Bracket Installation

iBoard®

STEP 15

Hold the plastic rocker panel cover up in position over the mounting tabs on the front and center Brackets, **(Fig 18)**. Apply removable tape, (masking tape for example), to the plastic cover. Mark the location of the mounting tabs onto the tape, not the cover. Use a sharp knife or hacksaw blade to carefully cut out a section of the cover to clear each mounting tab. **IMPORTANT:** Trim as little as possible to clear the mounting tab and hardware.

NOTE: Primarily, the cover will need to be trimmed to clear the tab on the Passenger Center Mounting Bracket (PCM), **(Fig 18)**. The front of the cover may only need minor trimming to clear the tab, **(Fig 16)**.

Reinstall the rocker cover with the factory hardware once properly cleared.

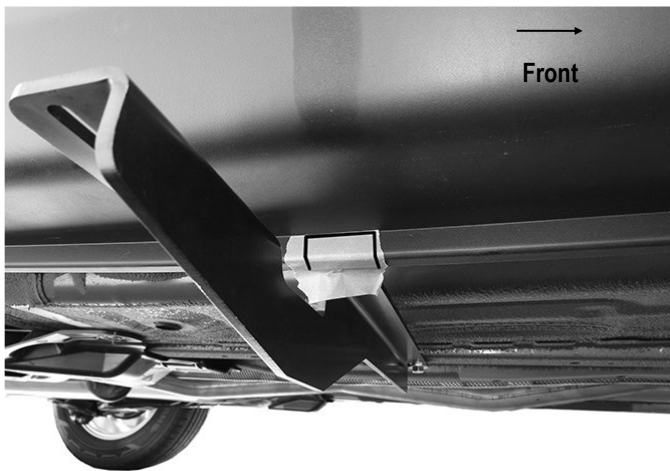

**(Fig 18) Passenger Side Center Bracket Pictured
(Marks indicating area to cut are for example only)**

STEP 16

Reinstall the Running Board as previously described. Level and adjust the Running Board and fully tighten all hardware.

STEP 17

Repeat **Steps 1-16** for other side Running Board installation. The installation is completed.

Attention

Do periodic inspections to the installation to make sure that all hardware is secure and tight.

In order to protect your bars/boards, please use only mild soap/non-abrasive products for cleaning.