



iBoard® by APS

PART#: IB-180C&H

READ INSTRUCTIONS CAREFULLY BEFORE STARTING INSTALLATION. REMOVE CONTENTS FROM BOX AND VERIFY ALL PARTS ARE PRESENT. ASSISTANCE IS RECOMMENDED.

*ROCKER PANEL MOUNT
*NO DRILLING REQUIRED

Fastener Size	Tightening Torque (ft-lbs)	Required
6mm	6-7	X
8mm	16-18	√
10mm	31-32	√
12mm	56-58	X
14mm	92-94	X

PART LIST

Driver Side Step Bar

Front
↑

Passenger Side Step Bar

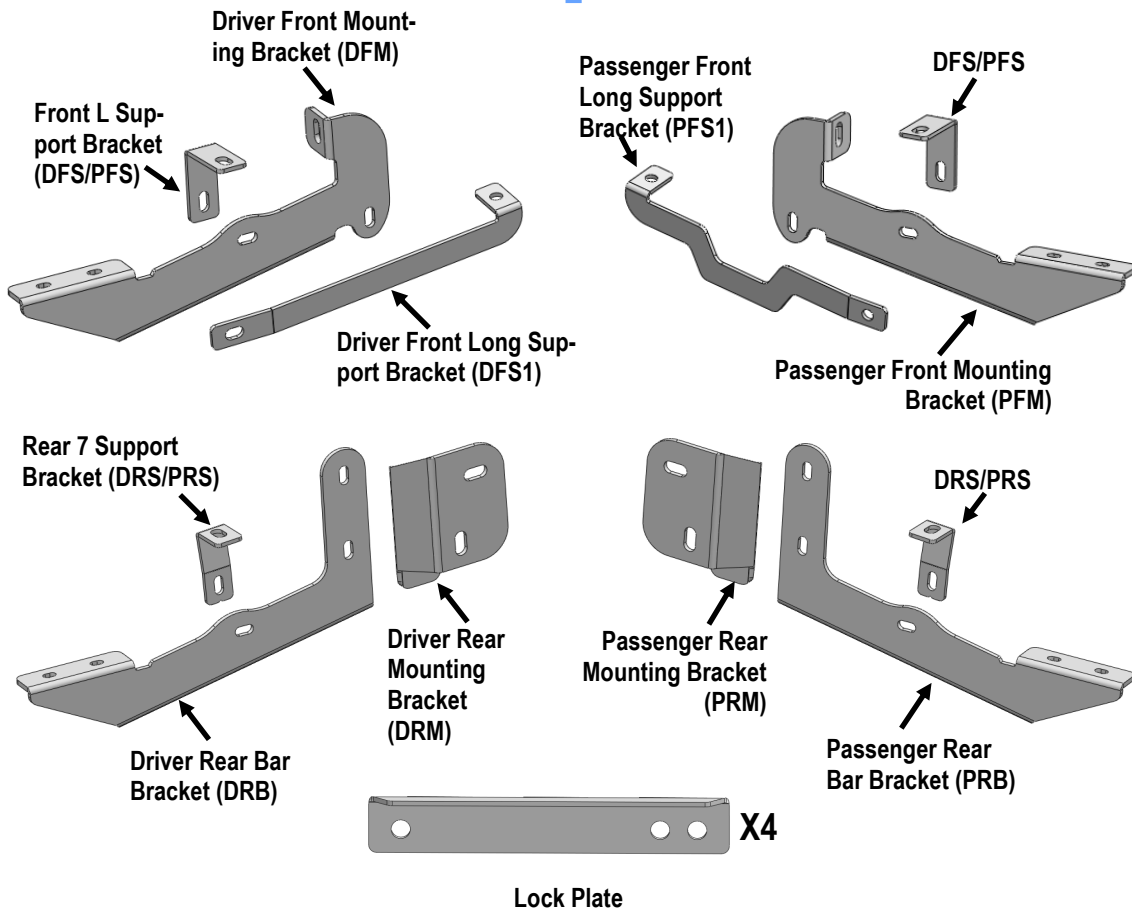
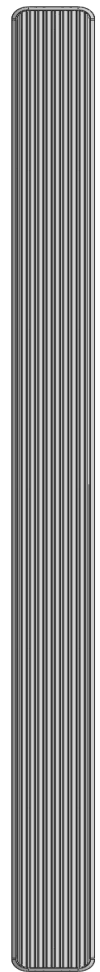
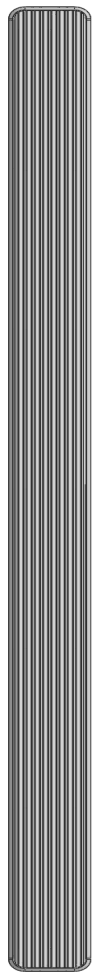



Hardware Package A (For Bracket Installation)

Item	QTY	Description	Item	QTY	Description
1#	2	M10 Double Bolt Plates	6#	16	M10 Hex Nuts
2#	12	M10 Bolt Plates	7#	10	M8X1.25-30mm Hex Bolts
3#	14	M10 Plastic Washers	8#	20	M8 Flat Washers
4#	16	M10 Flat Washers	9#	10	M8 Lock Washers
5#	16	M10 Lock Washers	10#	10	M8 Hex Nuts

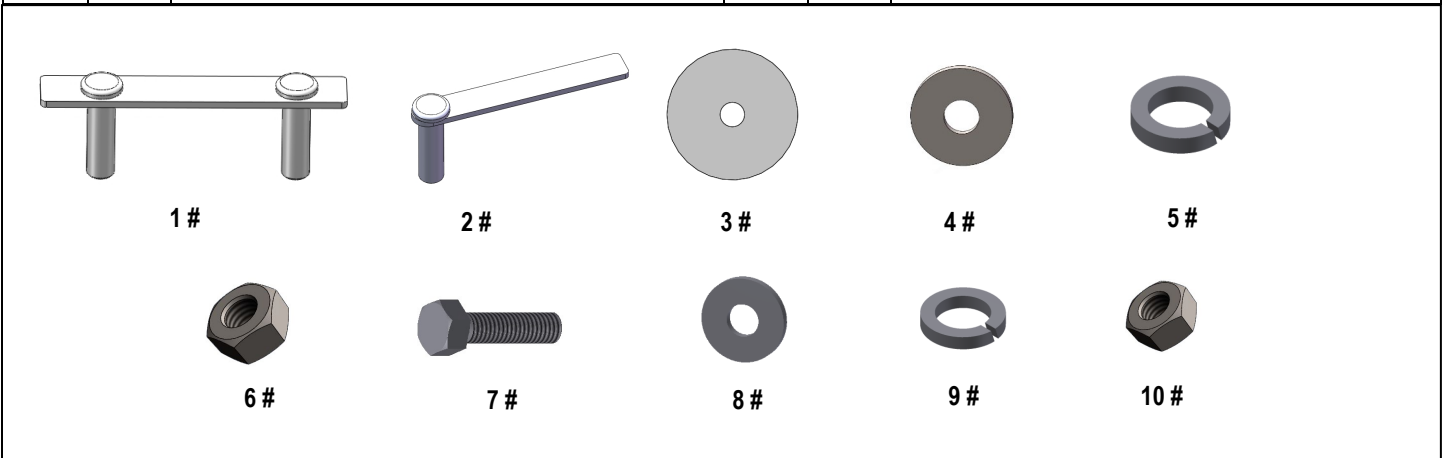

Hardware Package B (For Stainless Steel Step Bar Installation)

Item	QTY	Description	Item	QTY	Description
1#	8	M8X1.25-35mm Carriage Bolts	3#	8	M8 Nylon Lock Nuts
2#	8	M8 Large Flat Washers	4#	4	Sliders (Packed with Step Bars)

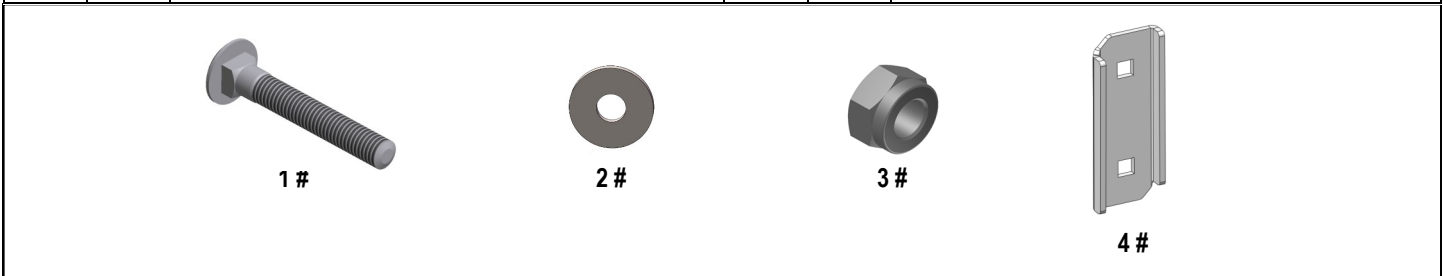



STEP 1

Start installation from the passenger side front of the vehicle. Locate and remove the (3) rubber plugs at the bottom of the outer frame channel closest to the front wheel opening, **(Fig 1)**.

STEP 2

Select (2) M10 Bolt Plates and (2) M10 Plastic Washers, **(Fig 2A)**. Thread (1) M10 Plastic Washer onto each M10 Bolt Plate. **NOTE:** The Plastic Washer is designed to keep the Bolt Plate from falling into the body panel during bracket installation. Insert (1) M10 Bolt Plate into the first-forward hole with the plate pointed toward the rear of the vehicle, **(Fig 2B)**. Thread the M10 Plastic Washer down tight against the body panel. Repeat to install the next M10 Bolt Plate into the second hole with the Plate pointed toward the front of the vehicle, **(Figs 2B & 3)**.

Note: The Plates on the (2) Bolt Plates must be pointed toward each other, **(Fig 3)**.

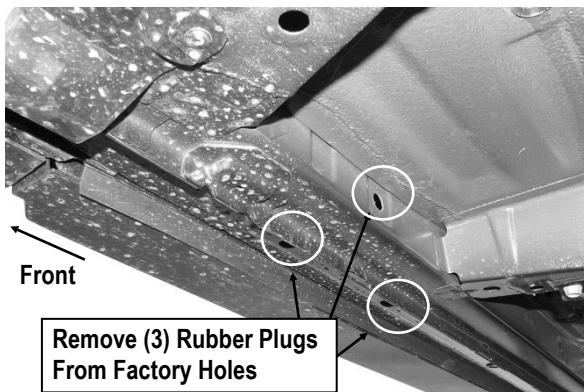

(Fig 1) Passenger Front Mounting Location

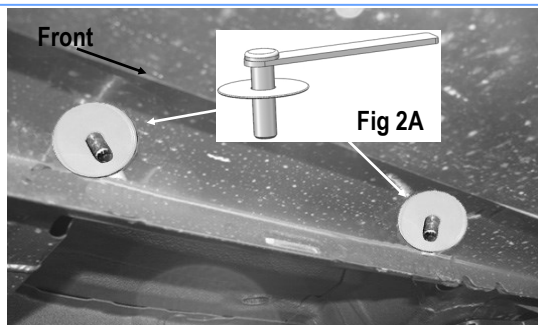

(Fig 2B) M10 Bolt Plates and M10 Plastic Washers Installation

STEP 3

Select (1) Lock Plate, **(Fig 3)**. Slide the Lock Plate over the installed (2) M10 Bolt Plates with the bent side toward the pinch weld. Attach the Lock Plate to the rear M10 Bolt Plate only with (1) M10 Flat Washer, (1) M10 Lock Washer and (1) M10 Hex Nut, **(Fig 4)**. Tighten the Hex Nut at this time.

IMPORTANT: Repeat this **Step** to install the other Lock Plate onto the passenger side rear mounting location.

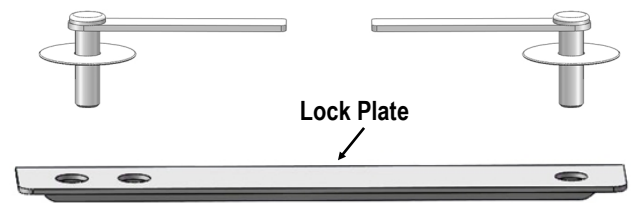

(Fig 3) Lock Plate

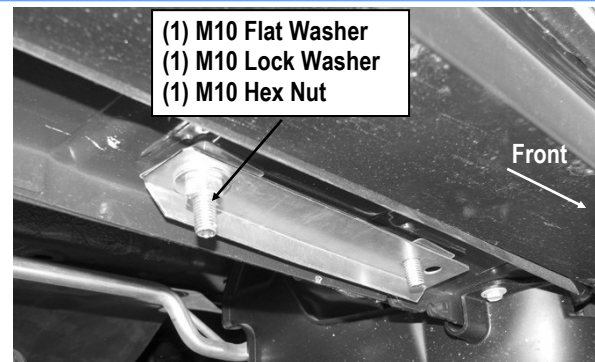

**(Fig 4) Lock Plate Installed
(On Passenger Side Front Mounting Location)**

STEP 4

Locate the round hole on the inner side of the outer frame channel close to the installed lock plate, **(Figs 1 & 5)**. Select (1) M10 Bolt Plate and (1) M10 Plastic Washer, **(Fig 2A)**. Partially thread the M10 Plastic Washer onto the M10 Bolt Plate. Insert the M10 Bolt Plate into the hole and thread the M10 Plastic Washer down tight against the body **(Fig 5)**. **Note:** Mounting areas may be covered with undercoating. Remove the undercoating from body panel on all mounting locations. Make sure the Brackets attach against the body panel flatly.

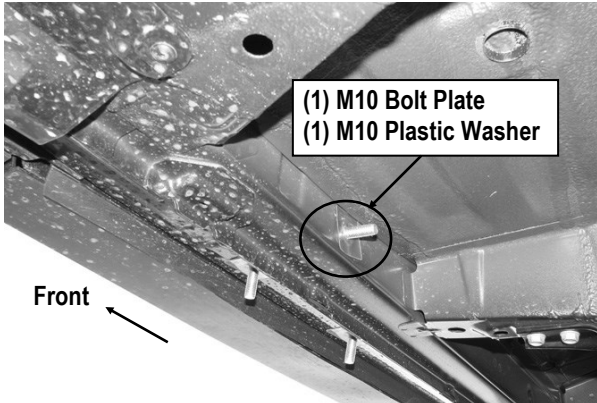

(Fig 5) M10 Bolt Plate Installed
(On the Passenger Side Front Mounting Location)

STEP 5

Select (1) Front L Support Bracket (**DFS/PFS**), (Fig 6). Attach the shorter end of the Support Bracket to the installed M10 Bolt Plate with (1) M10 Flat Washer, (1) M10 Lock Washer and (1) M10 Hex Nut, (Fig 7). Do not fully tighten hardware at this time.

Note: Front L Support Bracket (**DFS/PFS**) and Rear 7 Support Bracket (**DRS/PRS**) are different, (Fig 6).

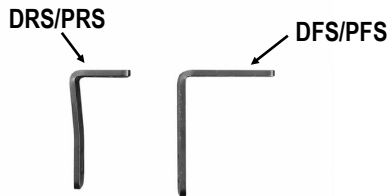
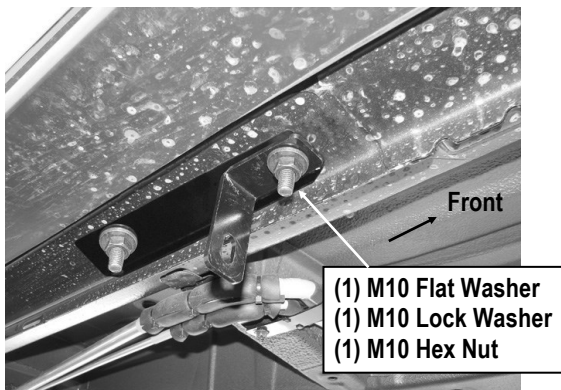

Fig 6



(Fig 7) Front L Support Bracket Installed
(On the Passenger Side Front Mounting Location)

STEP 6

Select the Passenger Front Mounting Bracket (**PFM**). Attach the Bracket to the upper M10 Bolt Plate installed on the back of the frame channel with (1) M10 Flat Washer, (1) M10 Lock Washer and (1) M10 Hex Nut, (Fig 8). Attach the Passenger Front Mounting Bracket to the back of the Front L Support Bracket (**DFS/PFS**) with (1) M8X1.25-30mm Hex Bolt, (2) M8 Flat Washers, (1) M8 Lock Washer and (1) M8 Hex Nut, (Figs 8 & 9). Do not fully tighten hardware at this time.

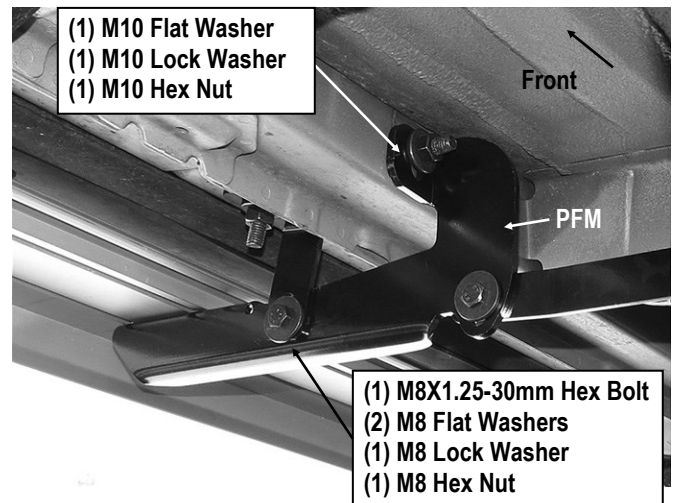

(Fig 8) Passenger Front Mounting Bracket (PFM) Installation

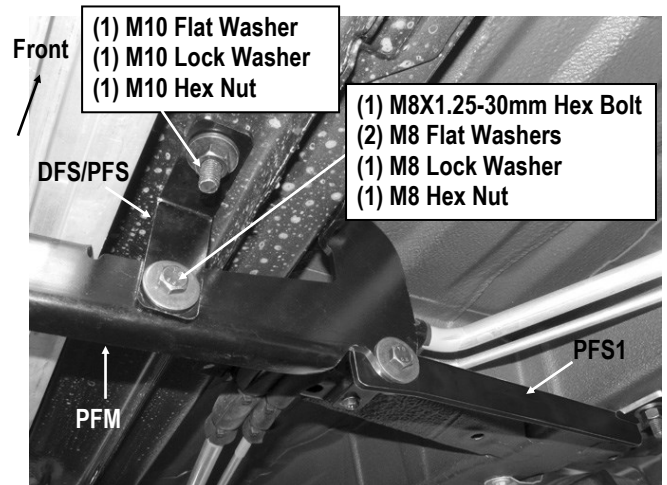

(Fig 9) Passenger Front Mounting Bracket (PFM) Installation



STEP 7

Next, locate the factory holes at the bottom of the inner frame channel directly behind the tie down loop where the frame is joined together. Select (1) M10 Bolt Plate and (1) M10 Plastic Washer. Partially thread the M10 Plastic Washer onto the Bolt Plate. Insert the Bolt Plate into the correct factory hole in the frame channel and thread the M10 Plastic Washer down tight against the body, **(Figs 10 & 12)**.

Select (1) Passenger Front Long Support Bracket (**PFS1**), **(Fig 13)**. Determine the correct factory hole to use:

For Passenger side: Use the 2nd factory hole back from the loop, **(Fig 10 & 11)**.

For Driver side: Use the factory hole closest to the loop, **(Fig 12)**.

Attach the short end of the Long Support Bracket to the M10 Bolt Plate on the frame channel with (1) M10 Flat Washer, (1) M10 Lock Washer and (1) M10 Hex Nut, **(Fig 10 –12)**.

Note: The driver side and passenger side Long Front Support Brackets do not install in the same manner.

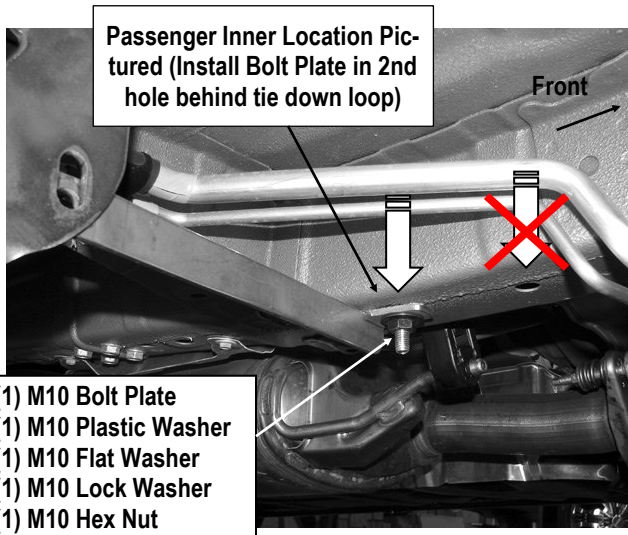

(Fig 10) Passenger Front Long Support Bracket (PFS1) Location (Bolt Support Bracket To Back Side Of Front Bracket)

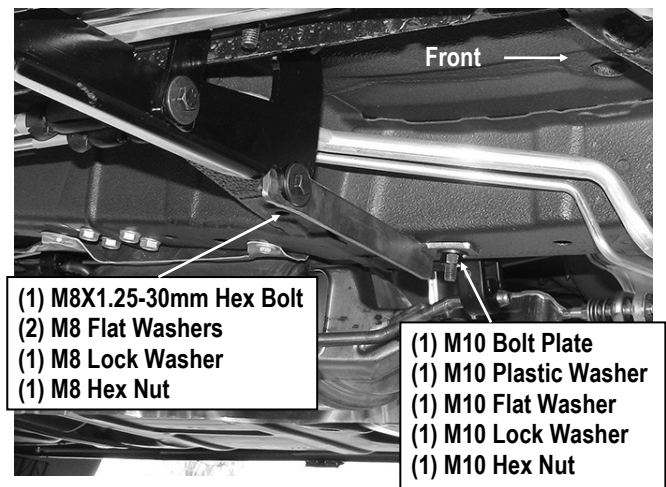

(Fig 11) Passenger Front Long Support Bracket (PFS1) Location

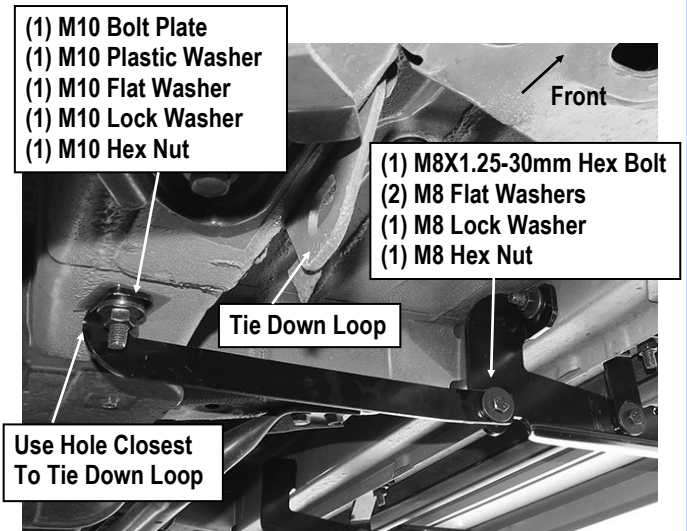

(Fig 12) Driver Front Long Support Bracket (DRS1) Location (Bolt Support Bracket To Front Side Of Front Mounting Bracket)

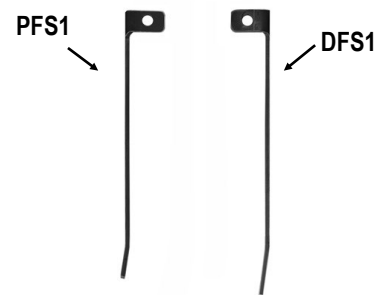

Fig 13



STEP 8

Bolt the long end of the Passenger Front Long Support Bracket (**PFS1**) to the Passenger Front Mounting Bracket (**PFM**) with (1) M8X1.25-30mm Hex Bolt, (2) M8 Flat Washers, (1) M8 Lock Washer and (1) M8 Hex Nut, (**Fig 11 & 14**). Do not fully tighten hardware at this time.

Note: Attach the passenger side Long Support Bracket to the **back** of the Front Mounting Bracket, (**Figs 10 & 11**).

Attach the driver side Long Support Bracket to the **front** of the Front Mounting Bracket, (**Fig 12**).

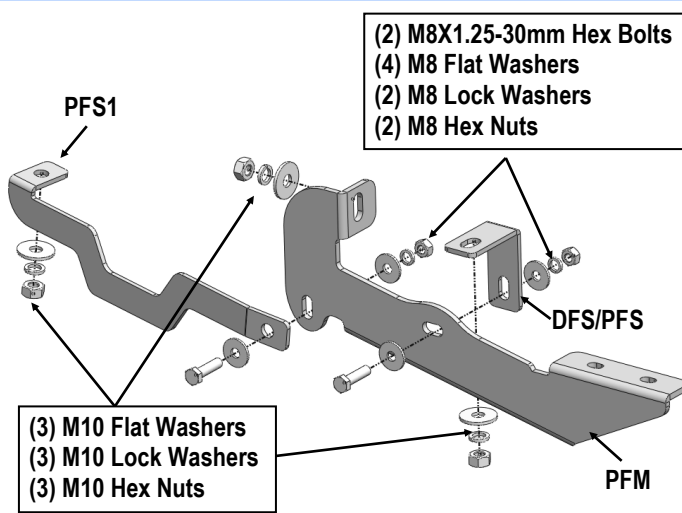

(Fig 14) Passenger Side Front Brackets Location

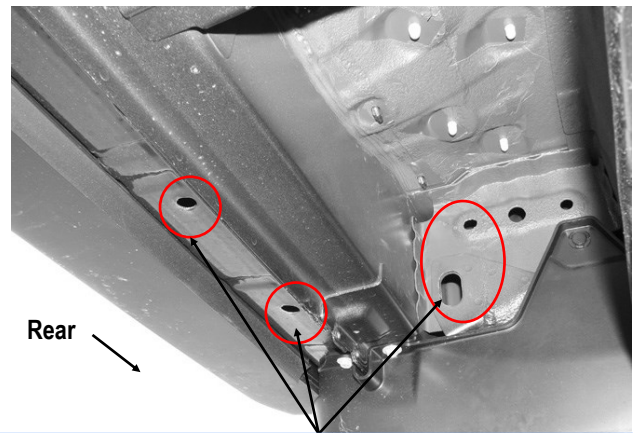

(Fig 15) Passenger Side Rear Mounting Location

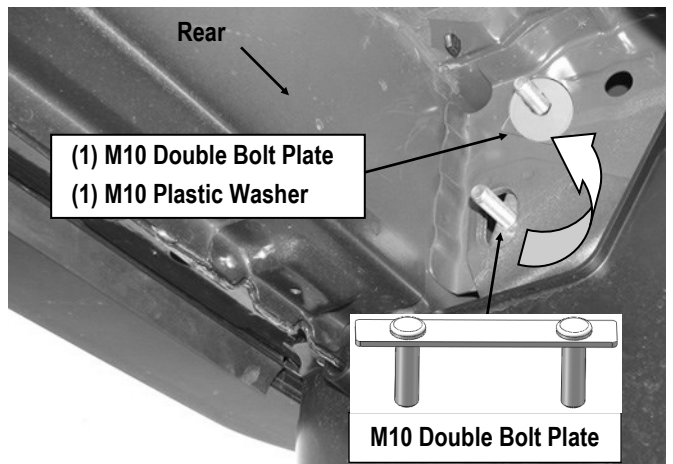

(Fig 16) M10 Double Bolt Plate Installation
(On Passenger Side Rear Mounting Location)

STEP 9

Move to the rear mounting location in front of the passenger side rear tire opening. Locate the large oval and the round holes in the inner body panel in front of the rear tire, (**Fig 15**). Select (1) M10 Double Bolt Plate and (1) M10 Plastic Washer. Insert the M10 Double Bolt Plate into the oval hole and up and out of the smaller round hole above it. Thread the Plastic Washer onto the M10 Double Bolt Plate in the round hole only, (**Fig 16**)

STEP 10

Locate the last (2) round holes along the floor panel, (**Fig 15**). Repeat **Steps 1-3** to install the (2) M10 Bolt Plates and (1) Lock Plate, (**Fig 17 & 18**).

NOTE: Attach the Lock Plate to the front of Bolt Plate only with (1) M10 Flat Washer, (1) M10 Lock Washer and (1) M10 Hex Nut, (**Fig 18**). Tighten the Hex Nut at this time.

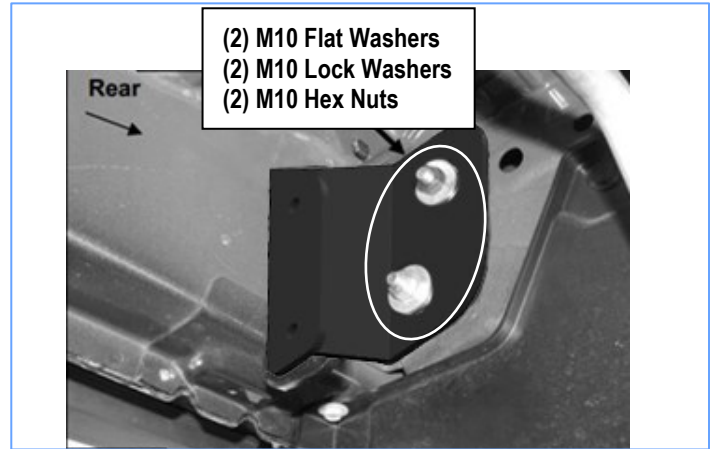
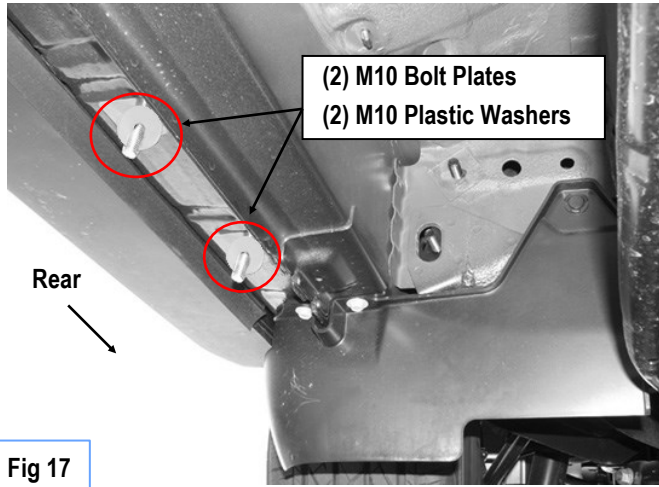

(Fig 19) Passenger Rear Mounting Bracket (PRM) Installation

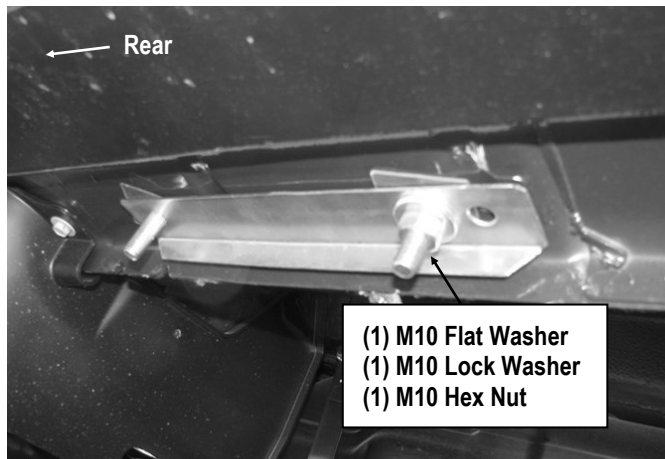

(Fig 18) Lock Plate Installation
(On Passenger Side Rear Mounting Location)

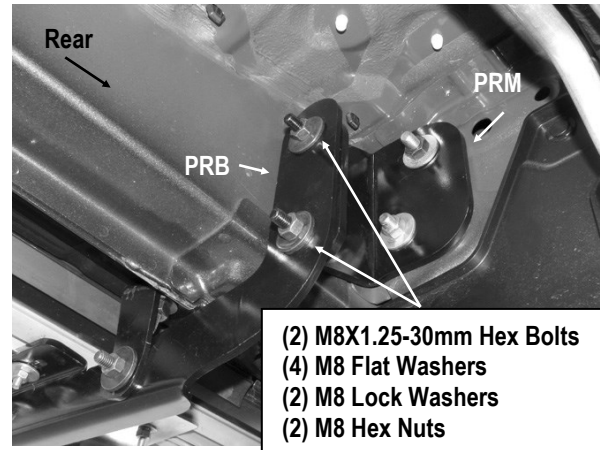

(Fig 20) Passenger Rear Bar Bracket (PRB) Installation

STEP 11

Select the Passenger Rear Mounting Bracket (**PRM**). Attach the Mounting Bracket to the installed M10 Double Bolt Plate with (2) M10 Flat Washers, (2) M10 Lock Washers and (2) M10 Hex Nuts, (**Fig 19**). Do not fully tighten hardware at this time.

Next, attach the Passenger Rear Bar Bracket (**PRB**) to the front of the Mounting Bracket with (2) M8X1.25-30mm Hex Bolts, (4) M8 Flat Washers, (2) M8 Lock Washers and (2) M8 X1.25 Hex Nuts, (**Fig 20**). Do not fully tighten hardware at this time.

STEP 12

Attach the Passenger Rear 7 Support Bracket (**DRS/PRS**) to the installed M10 Bolt Plate with (1) M10 Flat Washer, (1) M10 Lock Washer and (1) M10 Hex Nut, (**Fig 21 & 22**). Do not fully tighten hardware at this time.

Bolt the Passenger Rear 7 Support Bracket (**DRS/PRS**) to the back of the Passenger Rear Bar Bracket (**PRB**) with (1) M8X1.25-30mm Hex Bolt, (2) M8 Flat Washers, (1) M8 Lock Washer and (1) M8 Hex Nut, (**Fig 21 & 22**). Do not fully tighten hardware at this time.



STEP 13

Once all (2) Passenger side mounting brackets are installed, then proceed to the Step Bar installation. (Figs 23 & 24)

- (1) Select (1) Slider and (2) M8X1.25-35mm Carriage Bolts;
- (2) Install (2) M8X1.25-35mm Carriage Bolts in (1) Slider.
- (3) Slide the Slider (with carriage bolts) to the **Step Bar**.
- (4) Repeat to install the other (1) slider to the step bar.
- (5) Attach the Step Bar (with the Sliders) onto the installed mounting brackets. Position the Sliders to the installed brackets. Secure the Step Bar to the installed Brackets by using (4) M8 Large Flat Washers and (4) M8 Nylon Lock Nuts and (2) Sliders, (Fig 24). Do not fully tighten hardware at this time.

Note: The Sliders are packed with the Step Bars.

Level and adjust the Step Bar and fully tighten all hardware.

Repeat **Steps 1-13** for the other side Step Bar installation. **The installation is completed!!!**

Attention

Do periodic inspections to the installation to make sure that all hardware is secure and tight.

In order to protect your bars/boards, please use mild soap/non-abrasive products for cleaning only.

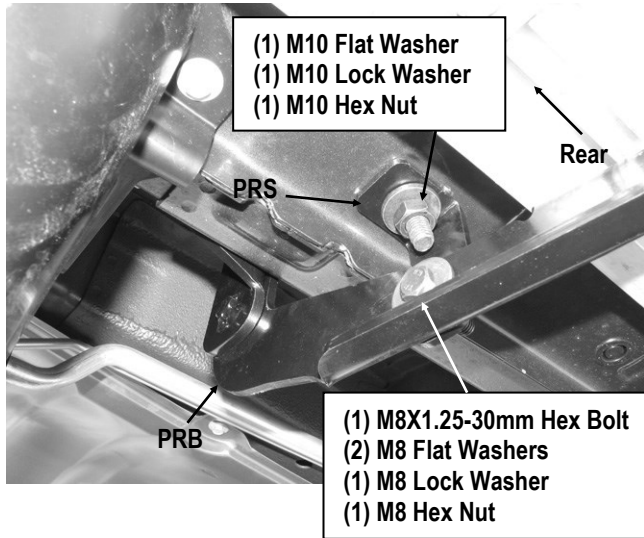

(Fig 21) Passenger Rear 7 Support Bracket (DRS/PRS) Installation

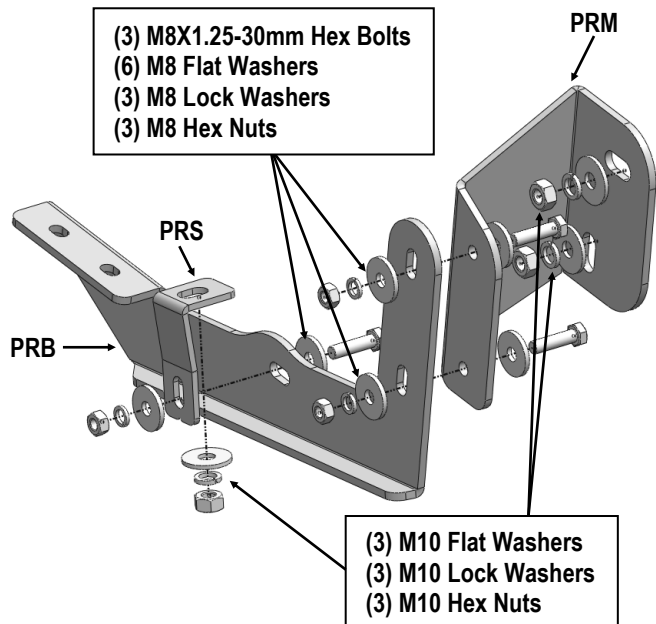

(Fig 22) Passenger Side Rear Bracket Location

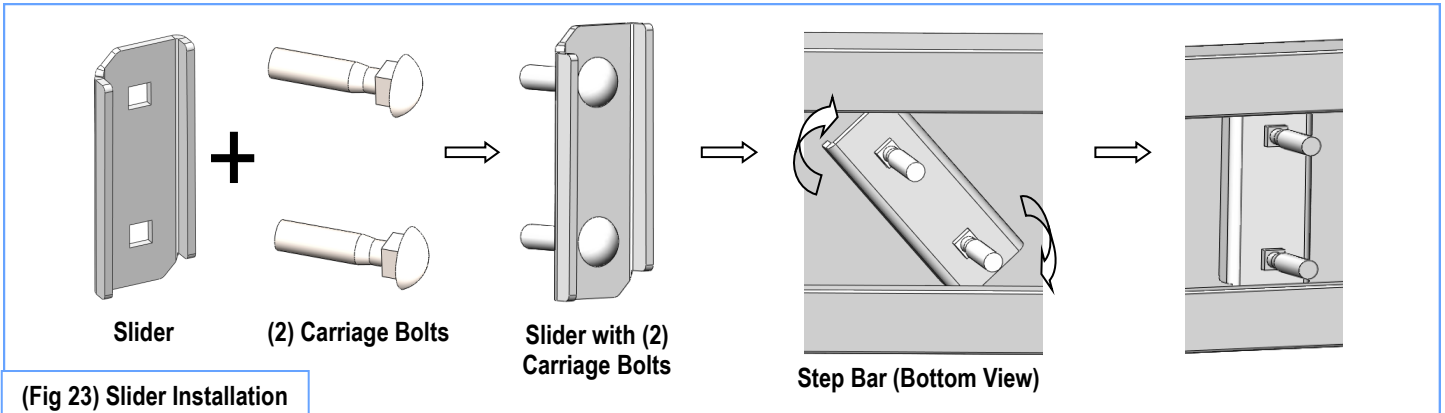

(Fig 23) Slider Installation

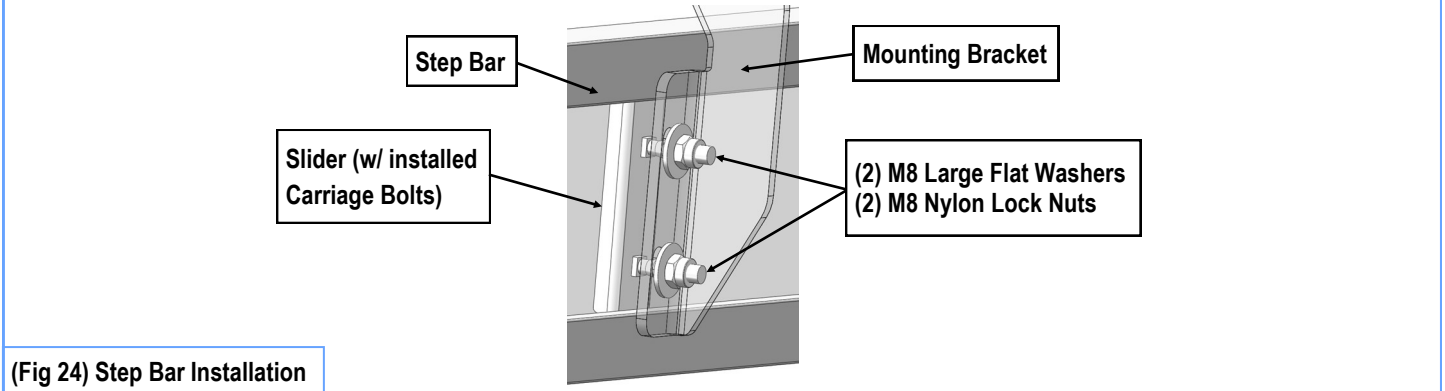

(Fig 24) Step Bar Installation