

# iBoard®

## iBoard® by APS

PART#: IB-338A-B

READ INSTRUCTIONS CAREFULLY BEFORE STARTING INSTALLATION. REMOVE CONTENTS FROM BOX AND VERIFY ALL PARTS ARE PRESENT. ASSISTANCE IS RECOMMENDED.

\*BODY FRAME MOUNT  
\*NO DRILLING REQUIRED

Fastener Size	Tightening Torque (ft-lbs)
6mm	6-7
8mm	16-18
10mm	31-32
12mm	56-58
14mm	92-94

### PART LIST

Front  
↑

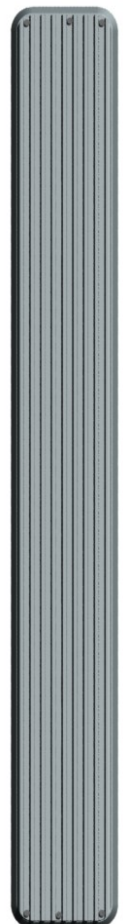
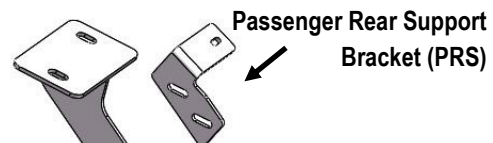
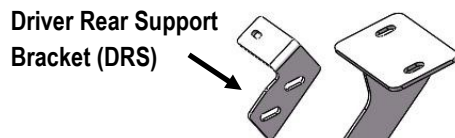
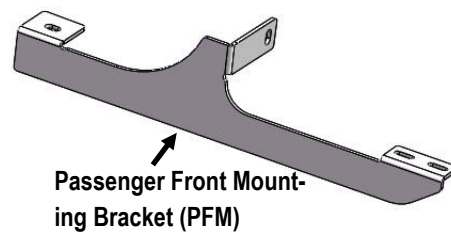
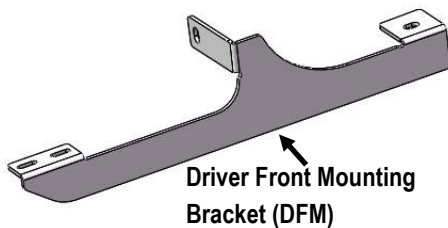

Customer Support: [info@iboardauto.com](mailto:info@iboardauto.com)

# iBoard®

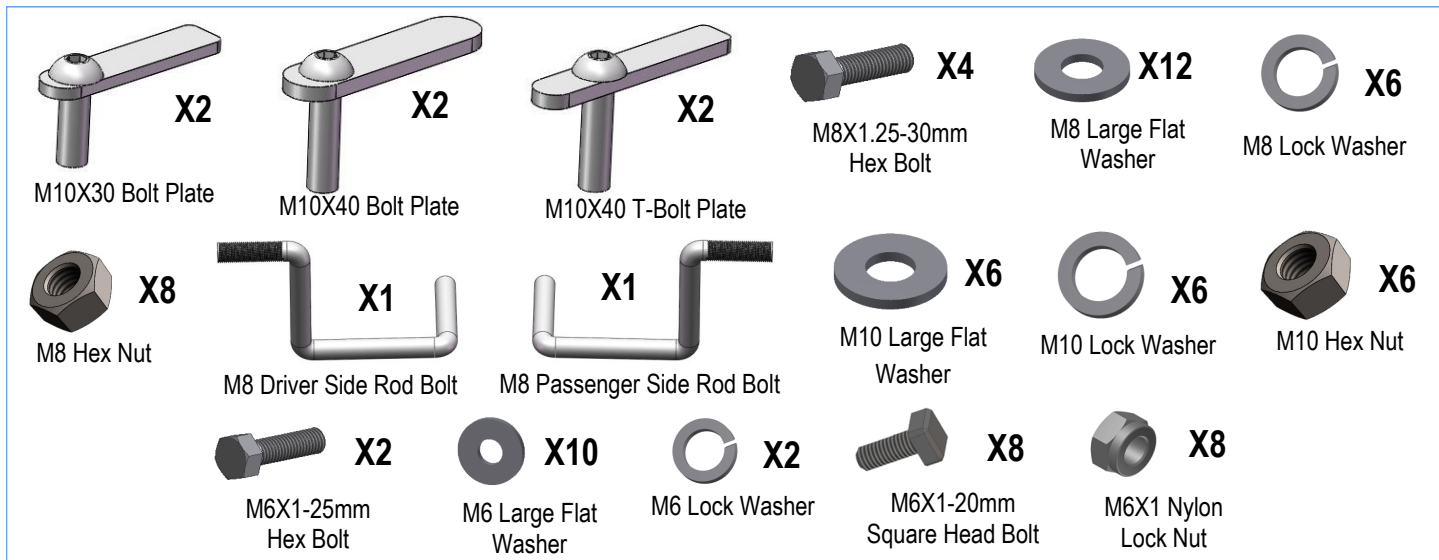

## STEP 1

Start installation from the driver side front of the vehicle. Locate the round hole in the backside of the body panel, **(Fig 1)**. **NOTE:** The hole will be covered by sealing tape and undercoating. Use a small screwdriver to locate and remove the tape.

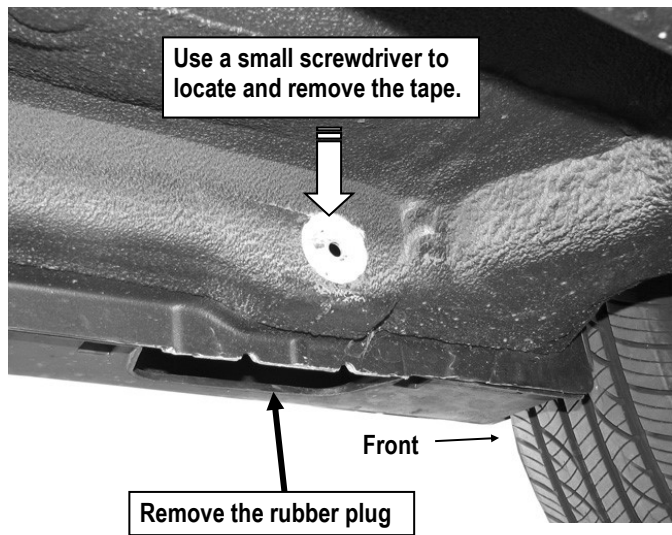

**(Fig 1) Driver Side Front Mounting Location Pictured**

## STEP 2

Remove the rubber plug covering the hole in the bottom of the body panel next to the pinch weld, **(Fig 2)**. Insert the M8 Driver Side Rod Bolt into the large hole in the bottom of the body panel and out the smaller hole in the backside of the body panel identified in **Step 1, (Fig 3)**.



**(Fig 2) Remove The Rubber Plug**

# iBoard®

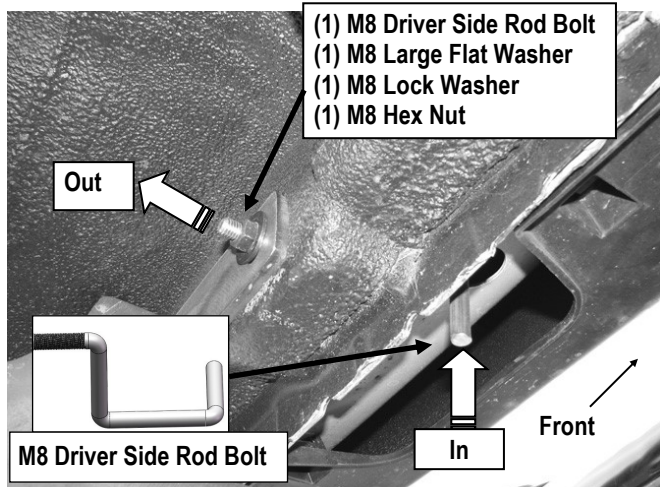

(Fig 3) Insert The M8 Driver Side Rod Bolt Into The Large Hole

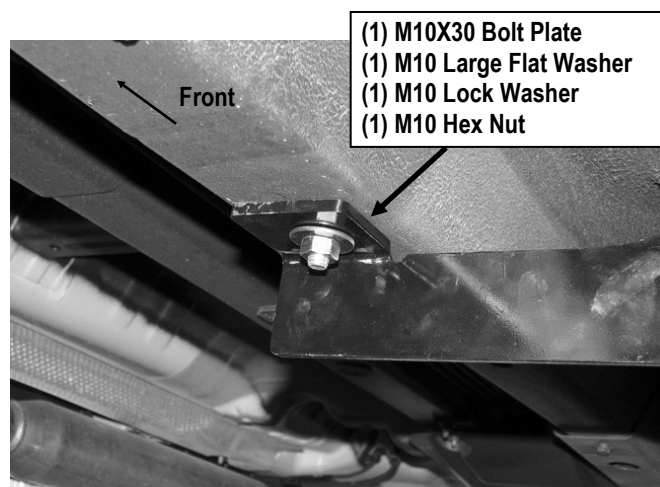

(Fig 5) Driver Side Front Mounting Bracket Installation

## STEP 3

Next, locate the oval slot in the bottom of the inner frame channel. Insert (1) M10X30 Bolt Plate into the frame channel, (Fig 4).

Select the Driver Front Mounting Bracket (DFM). Hang the bracket from the M8 Driver Side Rod Bolt with (1) M8 Large Flat Washer, (1) M8 Lock Washer and (1) M8 Hex Nut, (Fig 3). Secure the Bracket to the M10X30 Bolt Plate with the supplied (1) M10 Large Flat Washer, (1) M10 Lock Washer and (1) M10 Hex Nut, (Fig 5). Do not fully tighten the hardware at this time.

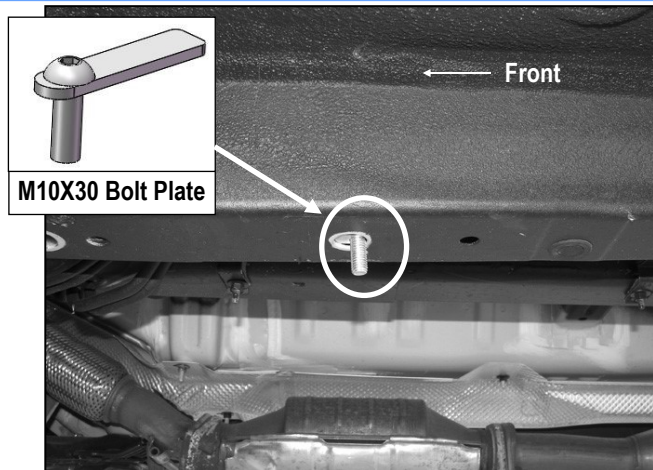

(Fig 4) Insert (1) M10X30 Bolt Plate Into The Frame Channel

## STEP 4

Move to the driver side rear of the vehicle. Remove the factory 6mm hex bolt securing the plastic cover to the floor channel, (Fig 6). Remove the rubber plugs covering the round and oval holes in the floor panel pictured in Fig 6.

Insert (1) M10X40 Bolt Plate into the round opening. Insert (1) M10X40 T-Bolt Plate into the oval opening, (Fig 7). **IMPORTANT:** Rotate T-Bolt Plate 90-degrees to the direction of the oval opening.

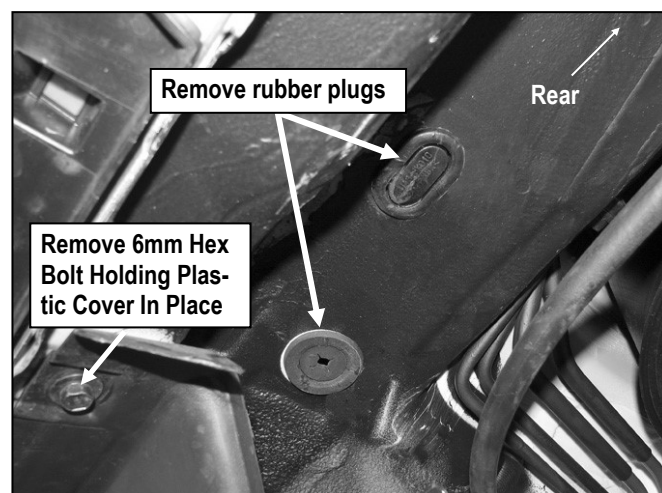

(Fig 6) Driver Side Rear Mounting Location Pictured



# iBoard®

## STEP 6

Select the Driver Rear Support Bracket (**DRS**). Hold the Bracket up to the threaded hole in the floor channel and insert the included (1) M6X1-25mm Hex Bolt with (1) M6 Lock Washer and (1) M6 Large Flat Washer through the plastic cover, the Support Bracket and into the floor channel, (**Fig 9**). Do not tighten hardware at this time.

Attach the Support Bracket to the Rear Mounting Bracket with the included (2) M8X1.25-30mm Hex Bolts, (4) M8 Large Flat Washers, (2) M8 Lock Washers and (2) M8 Hex Nuts, (**Fig 10**). Do not tighten hardware at this time.

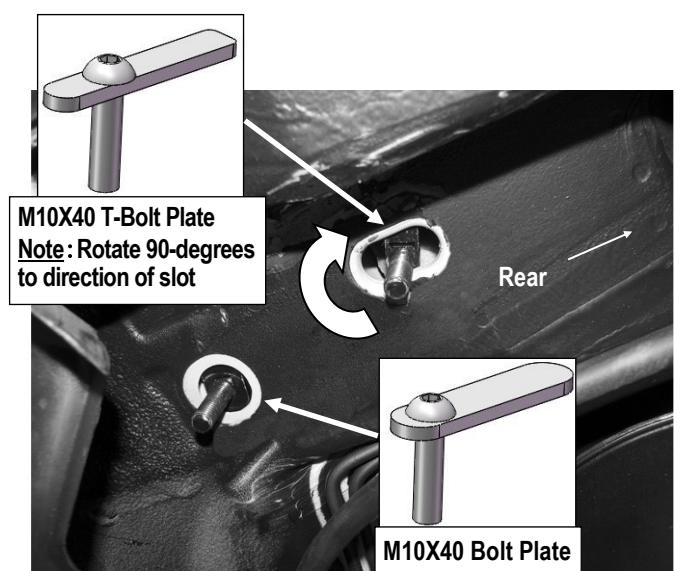

(Fig 7) Insert (1) M10X40 Bolt Plate And (1) M10X40 T-Bolt Plate

## STEP 5

Position the Driver Rear Mounting Bracket (**DRM**) up to the vehicle and partially attach the Bracket to the (2) M10X40 Bolt Plates inserted into the body panel. Secure using the included (2) M10 Large Flat Washers, (2) M10 Lock Washers and (2) M10 Hex Nuts, (**Fig 8**). Do not fully tighten the hardware at this time.

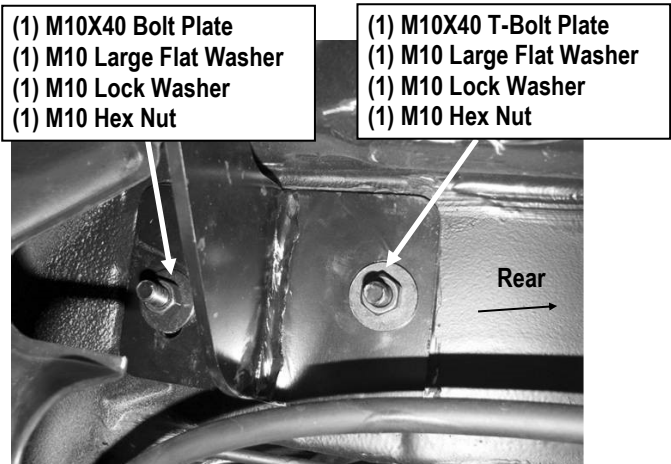

(Fig 8) Driver Side Rear Mounting Bracket Installation



(Fig 9) Driver Rear Support Bracket Installation

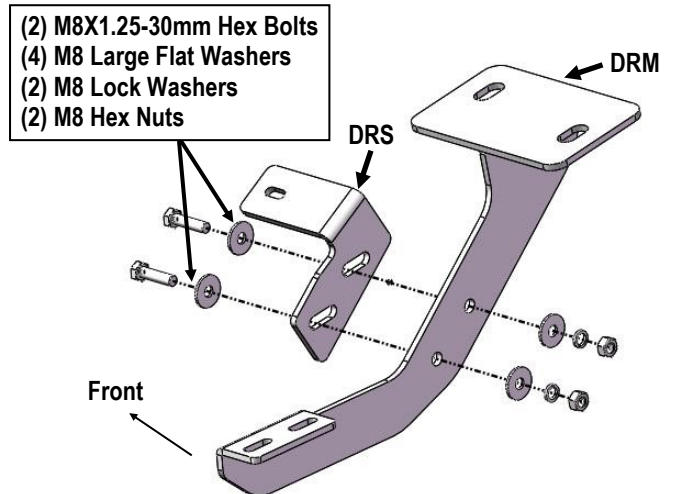

(Fig 10) Driver Side Rear Brackets Assembly

# iBoard®

## STEP 7

Select a Running Board. Slip (2) M6X1-20mm Square Head Bolts into each bottom channel (**Fig 11**). Carefully position the Running Board onto the (2) Mounting Brackets.

**IMPORTANT:** Do not slide the Running Board on the Brackets or the bottom surface of the board will be damaged. Attach the Running Board to each Mounting Bracket with (2) M6x1-20mm Square Head Bolts, (2) M6 Large Flat Washers and (2) M6 X1 Nylon Lock Nuts (**Fig 12**). Do not fully tighten at this time.



(Fig 11) Slip M6X1-20mm Square Head Bolts Into The Bottom Channels

(2) M6X1-20mm Square Head Bolts  
(2) M6 Large Flat Washers  
(2) M6X1 Nylon Lock Nuts

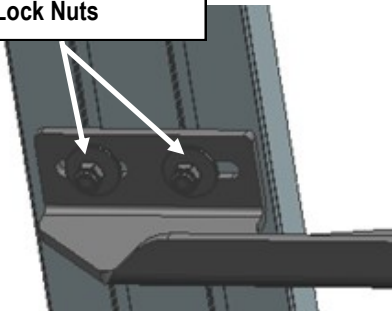

(Fig 12) Running Board Installed Onto the Mounting Bracket

## STEP 8

Level and adjust the Running Board and fully tighten all hardware.

## STEP 9

Repeat **Steps 1-9** for other side Running Board installation. The installation is completed (**Fig 13**).



(Fig 13) Installation Completed

### Attention

Do periodic inspections to the installation to make sure that all hardware is secure and tight.

In order to protect your bars/boards, please use only mild soap/non-abrasive products for cleaning.