

iBoard®

iBoard® by APS

PART#: IB-R963

READ INSTRUCTIONS CAREFULLY BEFORE STARTING INSTALLATION. REMOVE CONTENTS FROM BOX AND VERIFY ALL PARTS ARE PRESENT. ASSISTANCE IS RECOMMENDED.

***ROCKER PANEL MOUNT
*NO DRILLING REQUIRED**

| Fastener Size | Tightening Torque (ft-lbs) | Required |
|---------------|----------------------------|----------|
| 6mm | 6-7 | √ |
| 8mm | 16-18 | √ |
| 10mm | 31-32 | X |
| 12mm | 56-58 | X |
| 14mm | 92-94 | X |

| Item | QTY | Description | Item | QTY | Description |
|------|-----|---|------|-----|-----------------------------|
| 1# | 2 | Driver Front / Passenger Rear Mounting Brackets | 8# | 20 | M8 Lock Washers |
| 2# | 2 | Passenger Front / Driver Rear Mounting Brackets | 9# | 16 | M8 Hex Nuts |
| 3# | 2 | Driver Front / Passenger Rear Support Brackets | 10# | 4 | M8 Clip Nuts |
| 4# | 2 | Passenger Front / Driver Rear Support Brackets | 11# | 8 | M6X1-20mm Square Head Bolts |
| 5# | 12 | M8X1.25-30mm Hex Bolts | 12# | 8 | M6 Large Flat Washers |
| 6# | 8 | M8X1.25-25mm Hex Bolts | 13# | 8 | M6 Nylon Lock Nuts |
| 7# | 36 | M8 Flat Washers | | | |

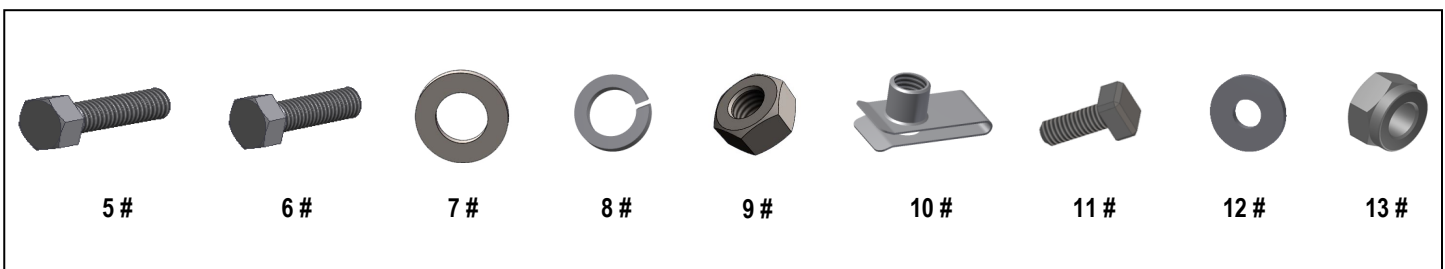

iBoard®

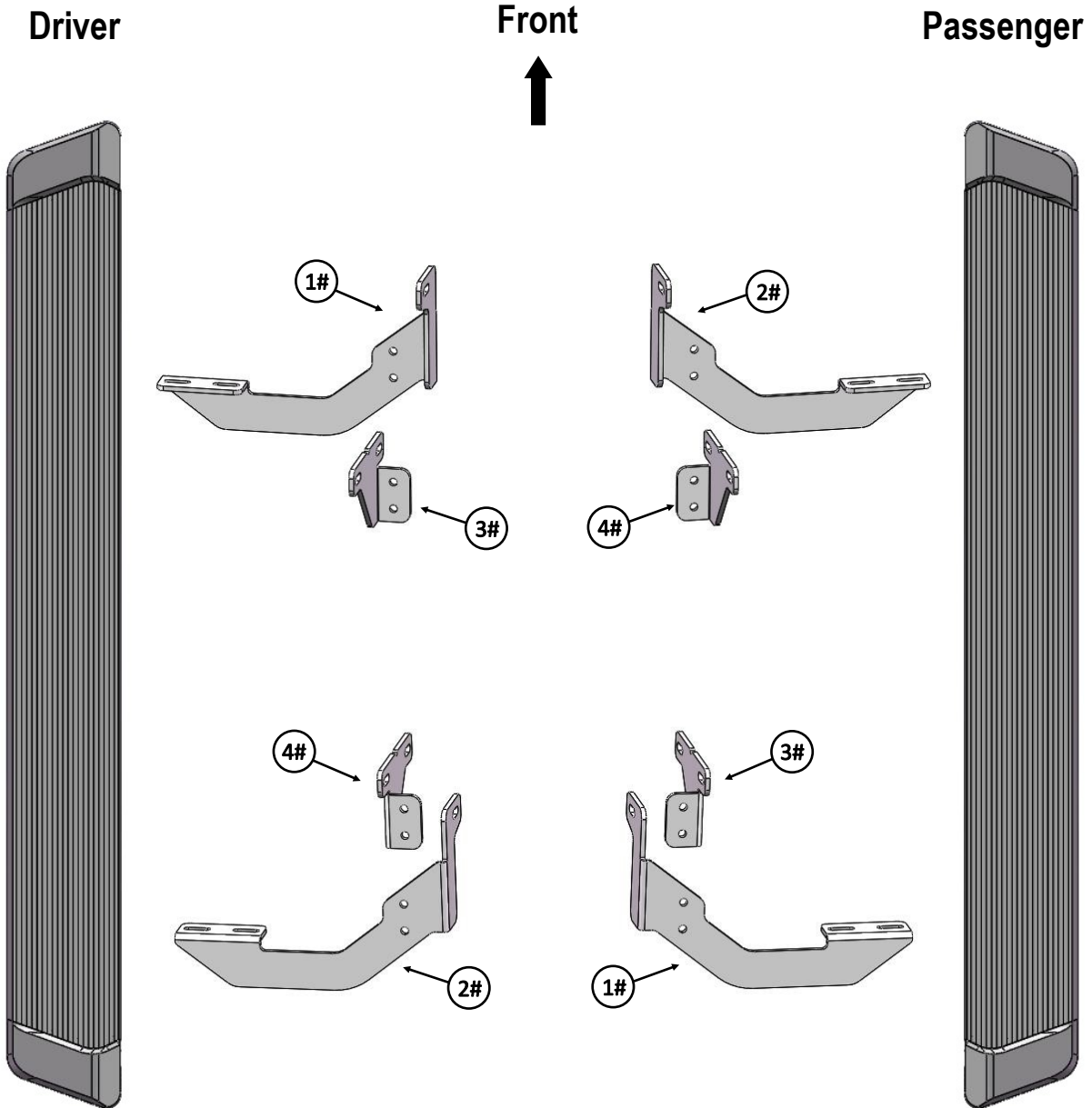

iBoard®

STEP 1

Start installation from the driver side of the vehicle. Identify the mounting locations along the rocker panel, (Fig 3).

STEP 2

Select (1) Driver Front Mounting Bracket and (1) Driver Front Support Bracket, assemble with (2) M8X1.25-25mm Hex Bolts, (4) M8 Flat Washers, (2) M8 Lock Washers and (2) M8 Hex Nuts, (Fig 1). Do not fully tighten hardware at this time.

Repeat for Driver Rear Mounting Bracket and Driver Rear Support Bracket assemble, (Fig 2).

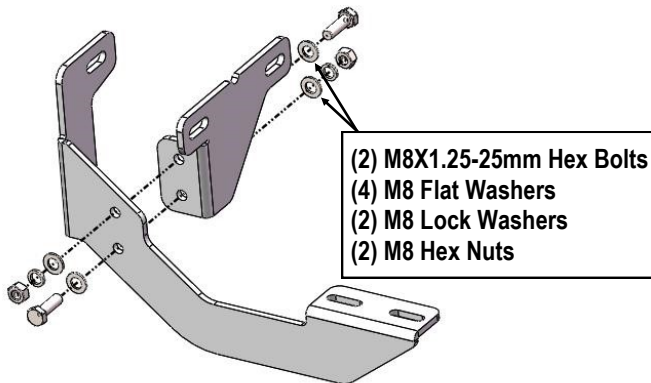

(Fig 1) Driver Side Front Mounting Bracket Assembly

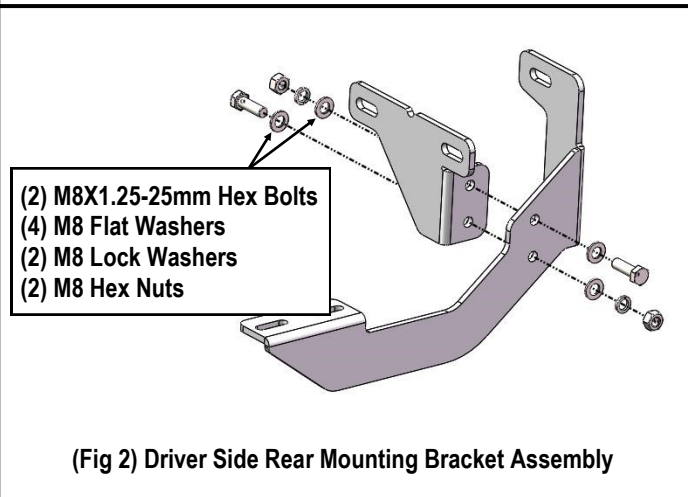

(Fig 2) Driver Side Rear Mounting Bracket Assembly

STEP 3

Attach (2) assembled Driver Side Mounting Brackets onto the mounting locations with (2) M8 Clip Nuts, (2) M8X1.25-30mm Hex Bolt, (2) M8 Lock Washers and (2) M8 Flat Washers; attach to the rocker panel with (4) M8X1.25-30mm Hex Bolts, (8) M8 Flat Washers, (4) M8 Lock Washers and (4) M8 Hex Nuts, (Fig 3). Do not fully tighten hardware at this time.

STEP 4

For jeep Commanders only: To attach the Passenger Side Front Mounting Brackets, remove the (4) factory bolts that secure the rear air and heat line shroud.

Remove the shroud to gain access to top mounting location on the bracket. After bracket is installed and fasteners are tightened, reattach shroud with the (4) existing bolts previously removed, (Fig 4).

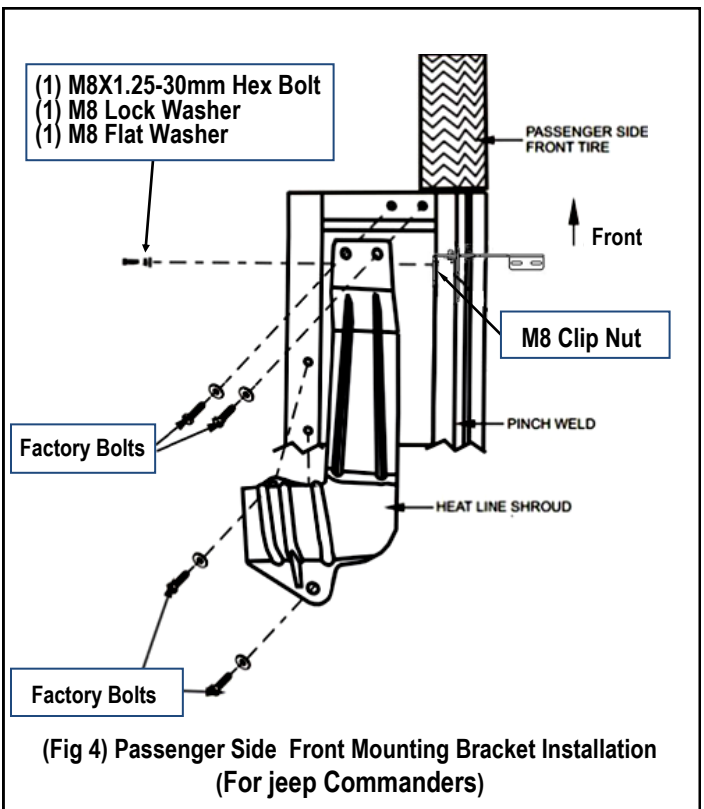

(Fig 4) Passenger Side Front Mounting Bracket Installation (For jeep Commanders)

iBoard®

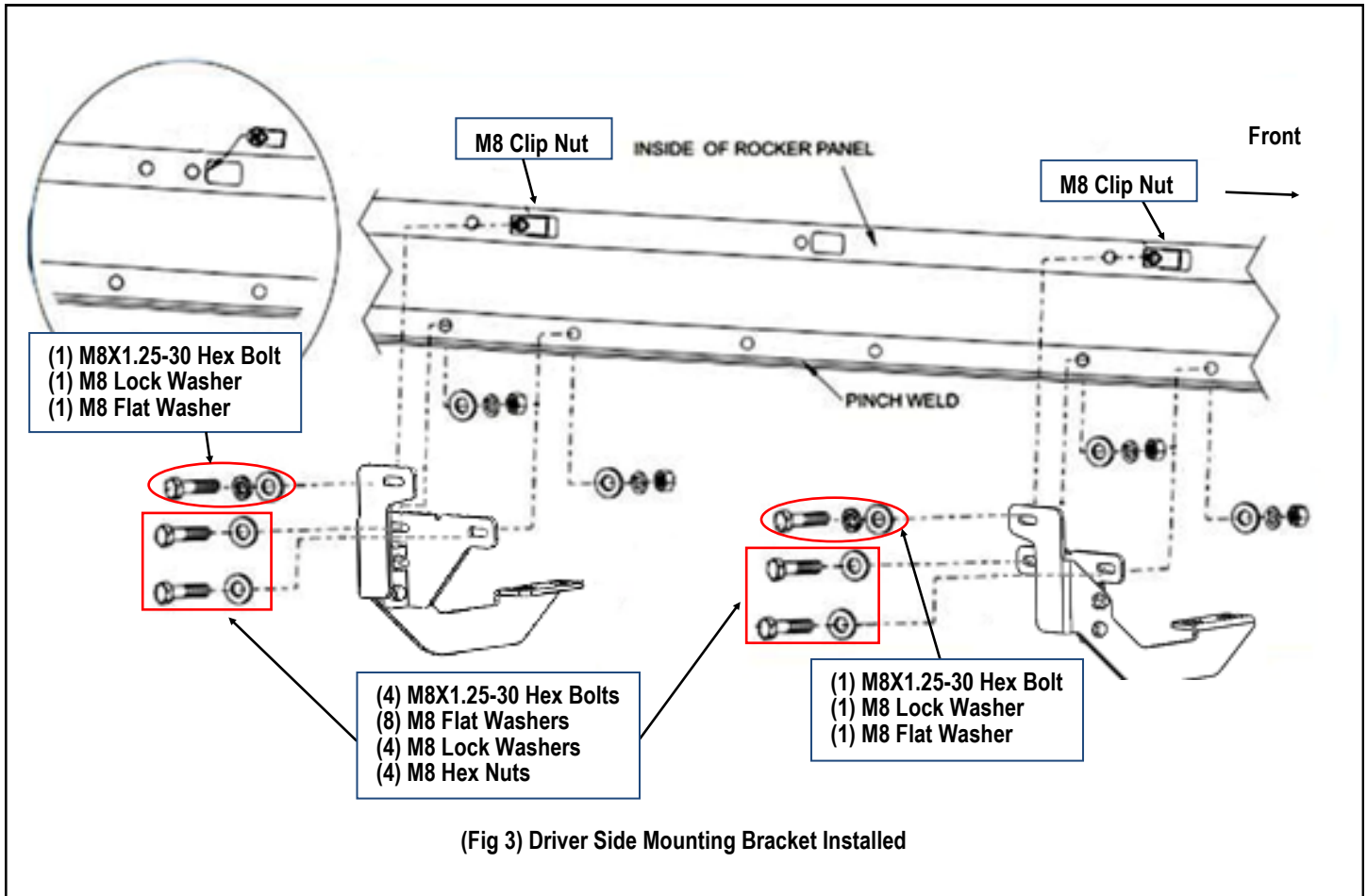

(Fig 3) Driver Side Mounting Bracket Installed

STEP 5

Select a Running Board. Slip (2) M6x1-20mm Square Head Bolts into each bottom channel (Fig 5). Carefully position the Running Board onto the (2) Mounting Brackets.

IMPORTANT: Do not slide the Running Board on the Brackets or the bottom surface of the board will be damaged. Attach the Running Board to each Mounting Bracket with (2) M6x1-20mm Square Head Bolts, (2) M6 Large Flat Washers and (2) M6 Nylon Lock Nuts (Fig 6). Do not fully tighten at this time.

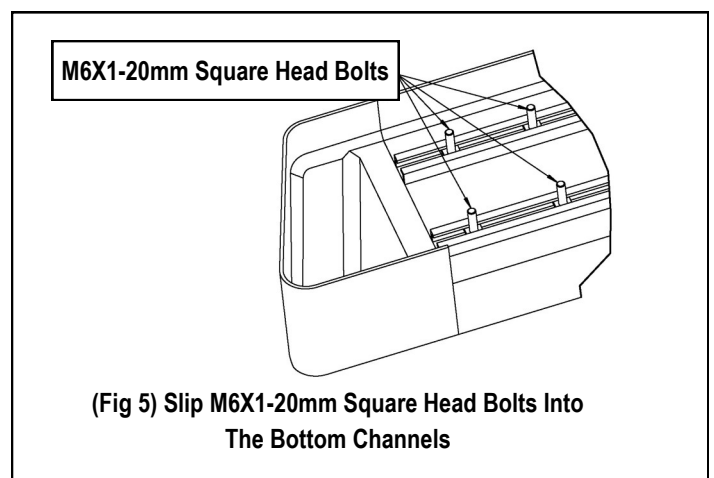

(Fig 5) Slip M6X1-20mm Square Head Bolts Into The Bottom Channels

iBoard®

- (2) M6X1-20mm Square Head Bolts
- (2) M6 Large Flat Washers
- (2) M6 Nylon Lock Nuts

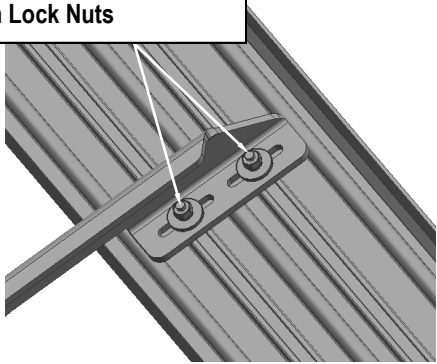

(Fig 6) Running Board Installed Onto Mounting Bracket

STEP 6

Level and adjust the Running Board and fully tighten all hardware.

Important: Please follow the recommended Tightening Torques shown in the table on page 1. Don't over tighten, or the nuts/bolts will be damaged.

STEP 7

Repeat **Steps 1-6** for the other side Running Board installation. The installation is completed.

Attention

Do periodic inspections to the installation to make sure that all hardware is secure and tight.

In order to protect your bars/boards, please use only mild soap/non-abrasive products for cleaning.