

iBoard®

iBoard® by APS

PART#: IB-R962

READ INSTRUCTIONS CAREFULLY BEFORE STARTING INSTALLATION. REMOVE CONTENTS FROM BOX AND VERIFY ALL PARTS ARE PRESENT. ASSISTANCE IS RECOMMENDED.

*ROCKER PANEL MOUNT
*DRILLING IS REQUIRED

Fastener Size	Tightening Torque (ft-lbs)	Required
6mm	6-7	√
8mm	16-18	√
10mm	31-32	X
12mm	56-58	X
14mm	92-94	X

Item	QTY	Description	Item	QTY	Description
1#	2	Driver / Passenger Front Mounting Brackets	7#	16	M8 Nylon Lock Nuts
2#	4	Driver / Passenger Center Mounting Brackets	8#	16	ST6.3x22mm Hex Self Tapping Screws
3#	2	Driver / Passenger Rear Mounting Brackets	9#	16	M6X1-20mm Square Head Bolts
4#	8	Support Brackets	10#	16	M6 Large Flat Washers
5#	16	M8X1.25-20mm Hex Bolts	11#	16	M6 Nylon Lock Nuts
6#	32	M8 Flat Washers			

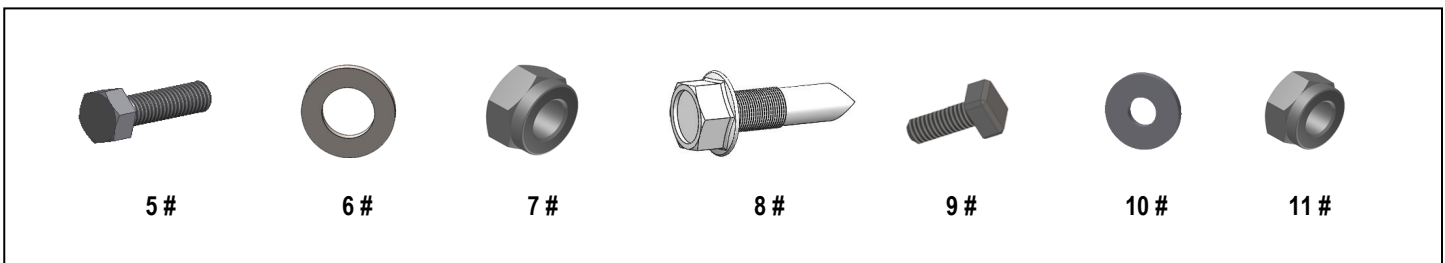

iBoard®

Driver

Front

Passenger

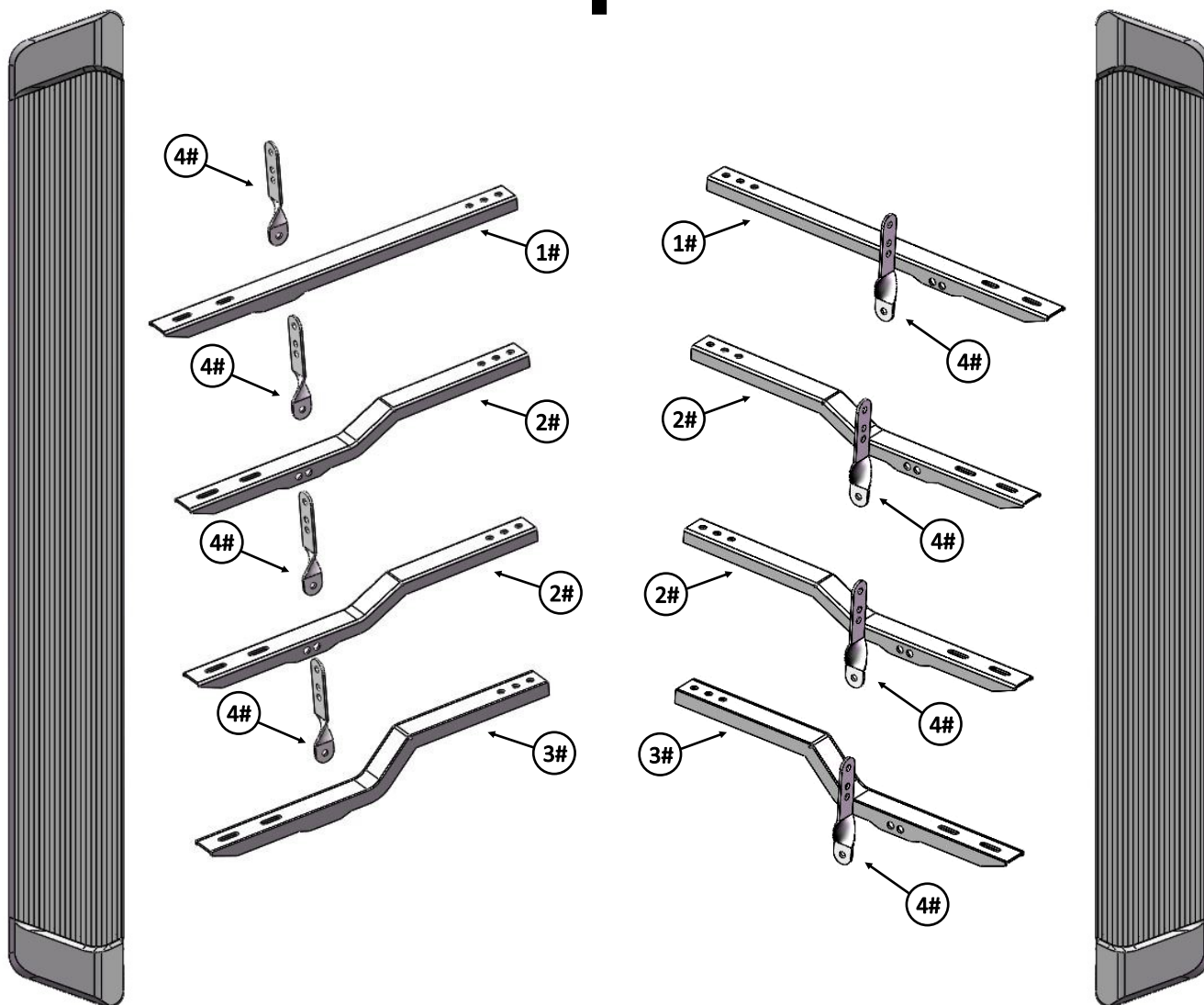

iBoard®

STEP 1

Start installing from the driver side of the vehicle, drill 5/16" holes on pinch weld as shown (Both sides), (Fig 1).

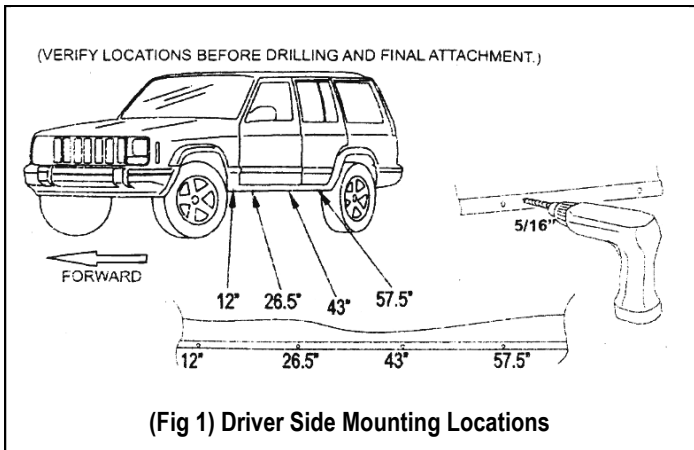

STEP 2

Assembly Driver Front Mounting Bracket and Support Bracket with (1) M8X1.25-20mm Hex Bolt, (2) M8 Flat Washers and (1) M8 Nylon Lock Nut, (Fig 2). Do not fully tighten at this time.

Then attach the assembled Driver Front Mounting Bracket to vehicle with (2) ST6.3x22mm Hex Self Tapping Screws, (1) M8X1.25-20mm Hex Bolt, (2) M8 Flat Washers and (1) M8 Nylon Lock Nut, (Fig 3). Do not fully tighten at this time.

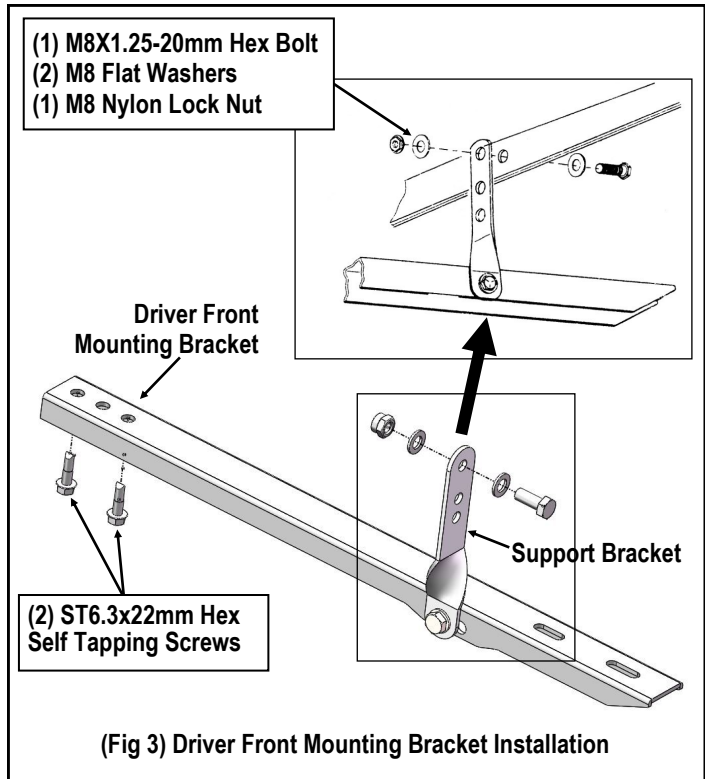
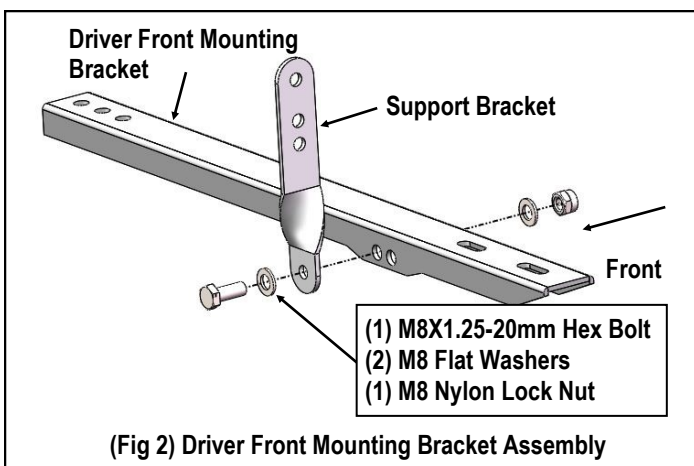

STEP 3

Move to driver side other (3) Mounting locations. Repeat **Steps 1-2** for Mounting Bracket and Support Bracket assembly and installation. Don't fully tighten hardware at this time.

STEP 4

Select a Running Board. Slip (4) M6x1-20mm Square Head Bolts into each bottom channel (Fig 4). Carefully position the Running Board onto the (4) Mounting Brackets.

IMPORTANT: Do not slide the Running Board on the Brackets or the bottom surface of the board will be damaged. Attach the Running Board to each Mounting Bracket with (2) M6x1-20mm Square Head Bolts, (2) M6 Large Flat Washers and (2) M6 Nylon Lock Nuts (Fig 5). Do not fully tighten at this time.

iBoard®

M6X1-20mm Square Head Bolts

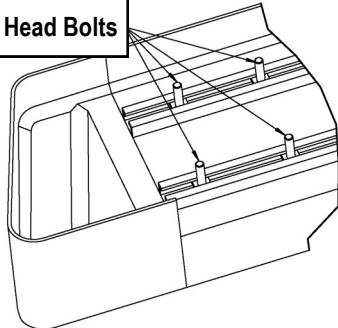

(Fig 4) Slip M6X1-20mm Square Head Bolts Into The Bottom Channels

(2) M6X1-20mm Square Head Bolts
(2) M6 Large Flat Washers
(2) M6 Nylon Lock Nuts

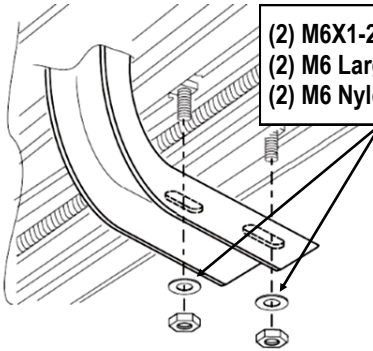

(Fig 5) Running Board Installed Onto Mounting Bracket

STEP 5

Level and adjust the Running Board and fully tighten all hardware.

Important: Please follow the recommended Tightening Torques shown in the table on page 1. Don't over tighten, or the nuts/bolts will be damaged.

STEP 6

Repeat **Steps 1-5** for the other side Running Board installation. The installation is completed.

Attention

Do periodic inspections to the installation to make sure that all hardware is secure and tight.

In order to protect your bars/boards, please use only mild soap/non-abrasive products for cleaning.