

iBoard®

iBoard® by APS

PART#: IB-R961

READ INSTRUCTIONS CAREFULLY BEFORE STARTING INSTALLATION. REMOVE CONTENTS FROM BOX AND VERIFY ALL PARTS ARE PRESENT. ASSISTANCE IS RECOMMENDED.

*ROCKER PANEL MOUNT
*DRILLING IS REQUIRED

Fastener Size	Tightening Torque (ft-lbs)	Required
6mm	6-7	√
8mm	16-18	√
10mm	31-32	X
12mm	56-58	X
14mm	92-94	X

PART LIST

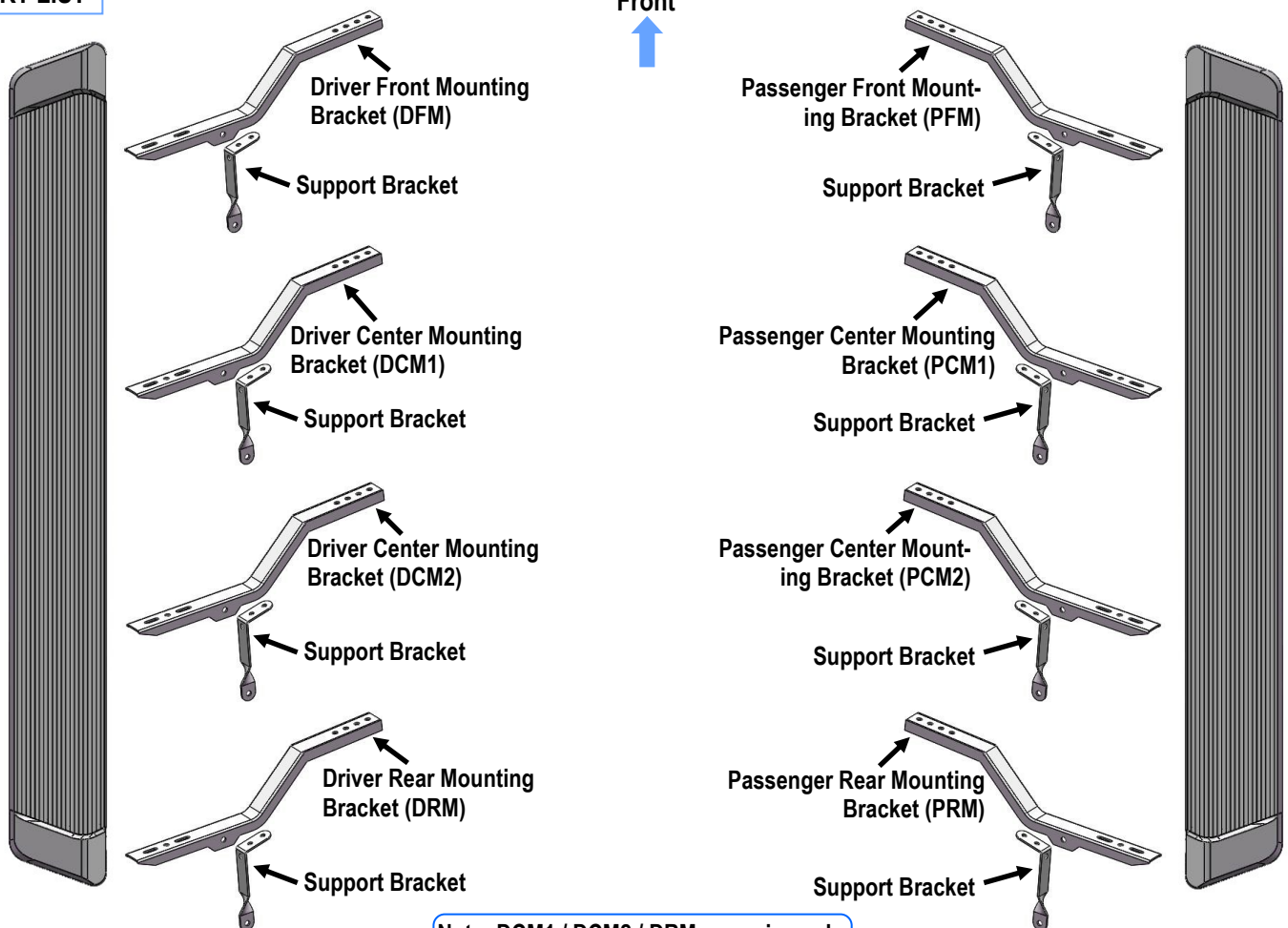

Note: DCM1 / DCM2 / DRM are universal
PCM1 / PCM2 / PRM are universal

Customer Support: info@iboardauto.com

iBoard®



STEP 1

Starting installation under the driver side of the vehicle. Drilling (4) M8 holes in pinch weld as shown, (Fig 1).

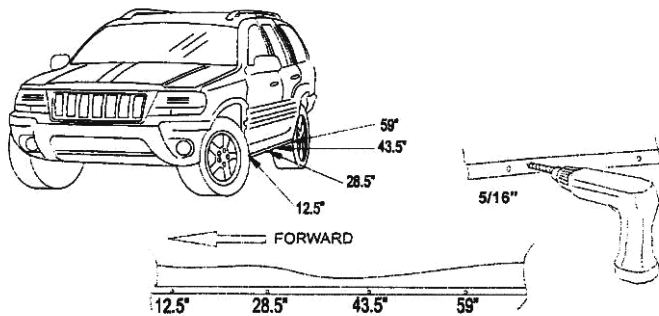

(Fig 1) Driver Side Mounting Location

STEP 2

Select (1) Support Bracket and (1) Driver Front Mounting Bracket (**DFM**). Assembly with (1) M8X1.25-20mm Hex Bolt, (2) M8 Flat Washers and (1) M8 Nylon Lock Nut, (Fig 3). Do not fully tighten hardware at this time.

Attach the assembled Driver Front Mounting Bracket to vehicle as shown, (Figs 2-3). Do not fully tighten hardware at this time.

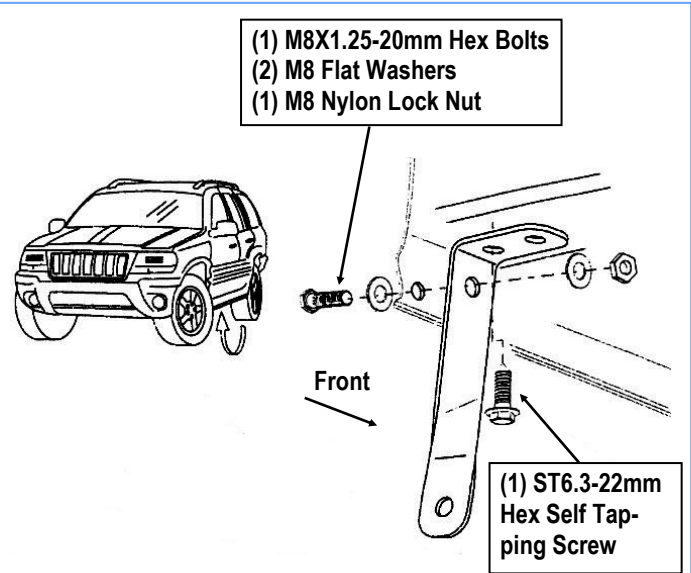

(Fig 2) Driver Side Front Mounting Bracket Installation

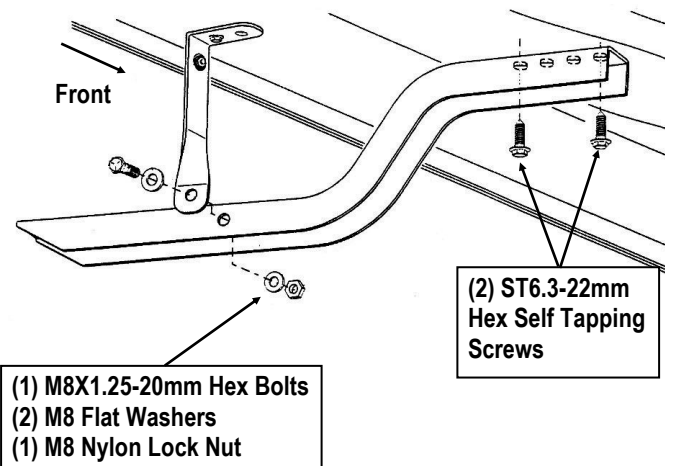

(Fig 3) Driver Side Front Mounting Bracket Installation

iBoard®

STEP 3

Move to the driver side other (3) mounting locations. Repeat **Steps 1-2** to attach the bracket to the vehicle. Do not fully tighten hardware at this time.

STEP 4

Select a Running Board. Slip (4) M6x1-20mm Square Head Bolts into each bottom channel (**Fig 4**). Carefully position the Running Board onto the (4) Mounting Brackets.

IMPORTANT: Do not slide the Running Board on the Brackets or the bottom surface of the board will be damaged. Attach the Running Board to Mounting Bracket with (2) M6x1-20mm Square Head Bolts, (2) M6 Large Flat Washers and (2) M6 X1 Nylon Lock Nuts (**Fig 5**). Do not fully tighten at this time.

Level and adjust the Running Board and fully tighten all hardware.

Important: Please follow the recommended Tightening Torques shown in the table on page 1. Don't over tighten, or the nuts/bolts will be damaged.

M6X1-20mm Square Head Bolts

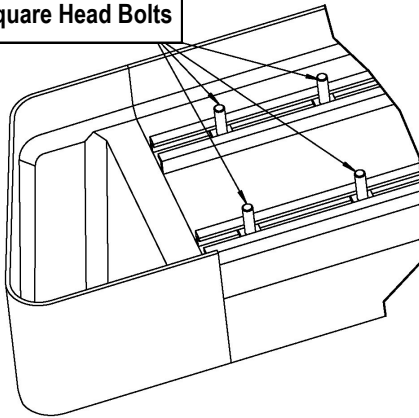

(Fig 4) Slip M6X1-20mm Square Head Bolts Into The Bottom Channels

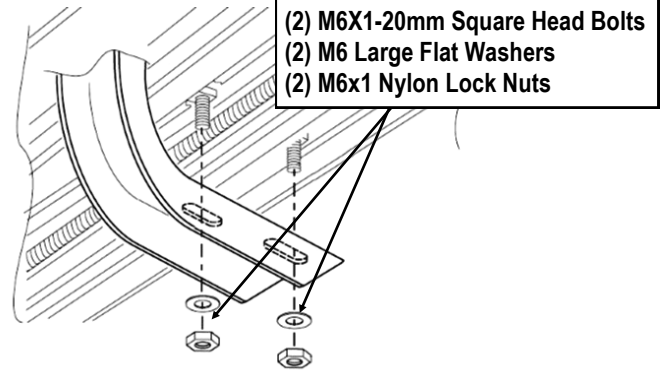

(Fig 5) Running Board Installed Onto Mounting Bracket

STEP 5

Repeat **Steps 1-4** for the other side Running Board installation. The installation is completed.

Attention

Do periodic inspections to the installation to make sure that all hardware is secure and tight.

In order to protect your bars/boards, please use only mild soap/non-abrasive products for cleaning.