

iBoard®

iBoard® by APS

PART#: IB-R107

READ INSTRUCTIONS CAREFULLY BEFORE STARTING INSTALLATION. REMOVE CONTENTS FROM BOX AND VERIFY ALL PARTS ARE PRESENT. ASSISTANCE IS RECOMMENDED.

*ROCKER PANEL MOUNT
*NO DRILLING REQUIRED

Fastener Size	Tightening Torque (ft-lbs)	Required
6mm	6-7	√
8mm	16-18	√
10mm	31-32	X
12mm	56-58	X
14mm	92-94	X

PART LIST

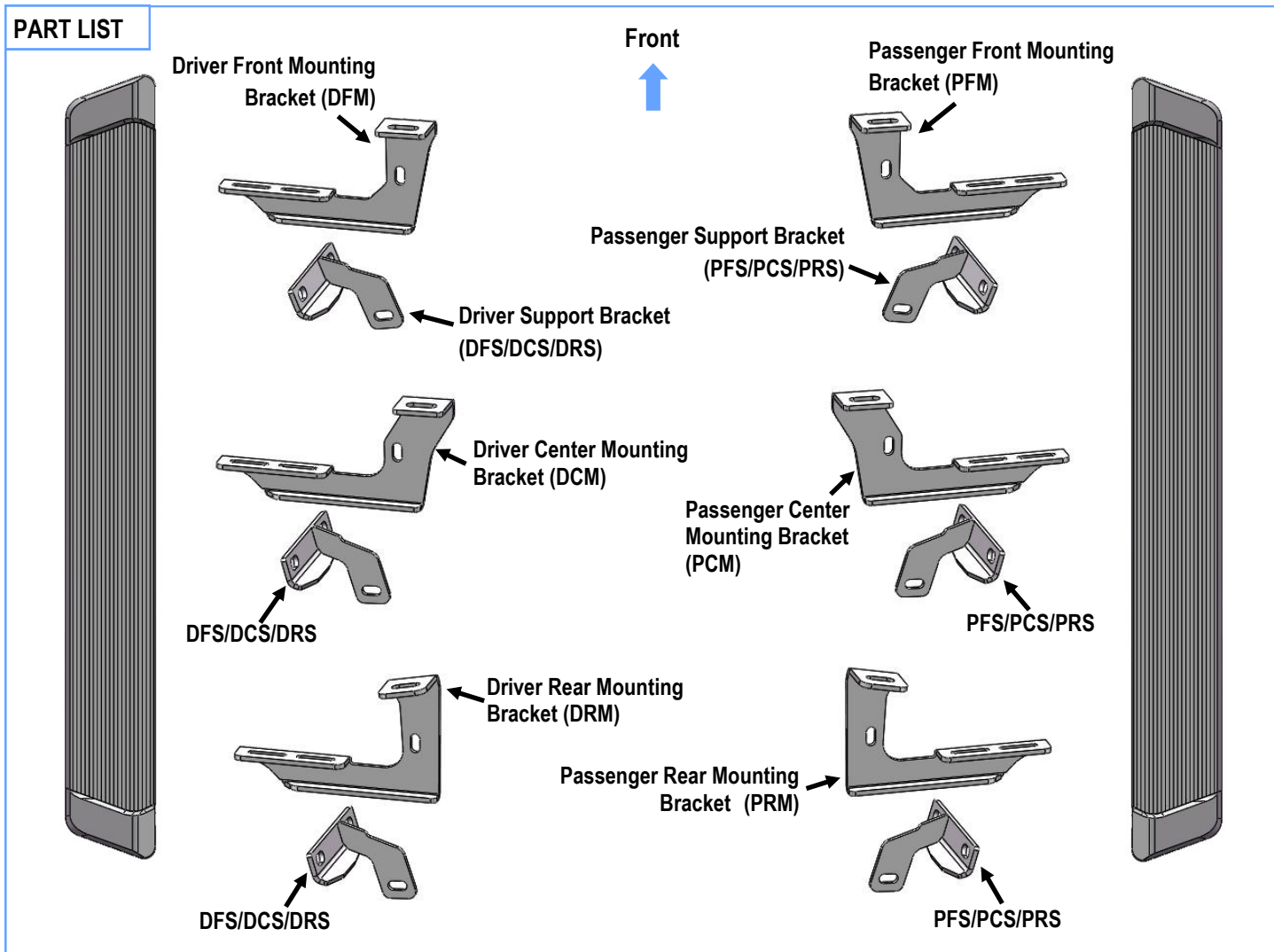

Customer Support: info@iboardauto.com

iBoard®

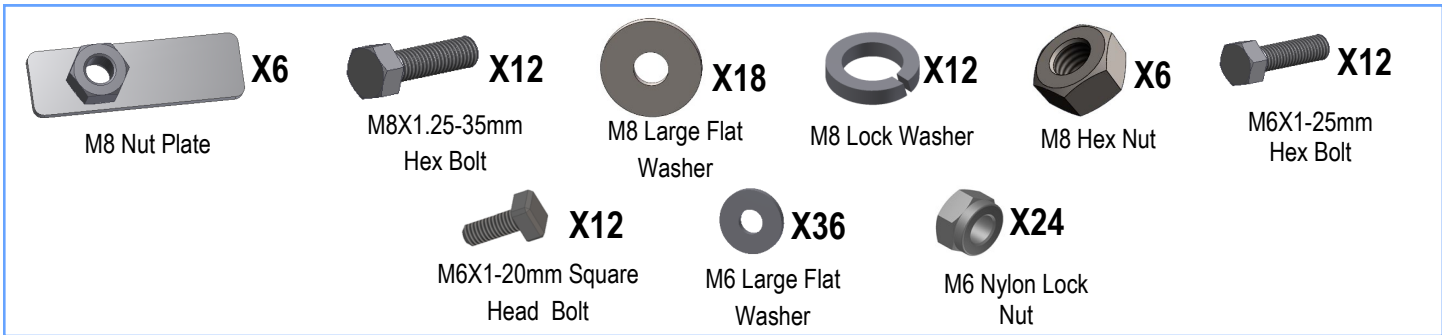

STEP 1

Starting on the Driver side front of the vehicle. Determine if the vehicle with open mounting locations or factory threaded holes in the floor panel.

A. Vehicles with open mounting location:

a. Insert (1) M8 Nut Plate into the large square opening in the floor panel. Line up the threaded nut with the hole in between the pair of holes on the pinch weld, (**Fig 1A, 1B & 2**).

b. Move along to the center/ rear mounting location, (**Fig 3**). Repeat **Step 1a** to insert the M8 Nut Plate into the center & rear opening on the floor panel.

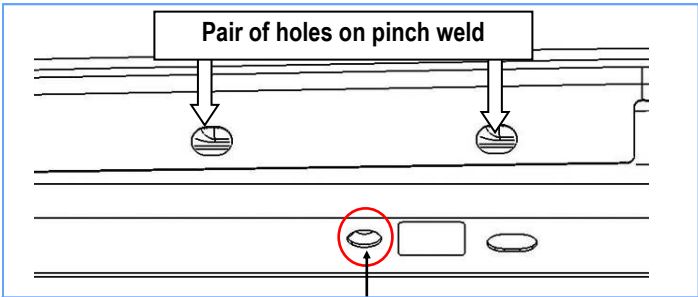

(Fig 2) Line up Nut Plate with hole in between the (2) holes on the pinch weld

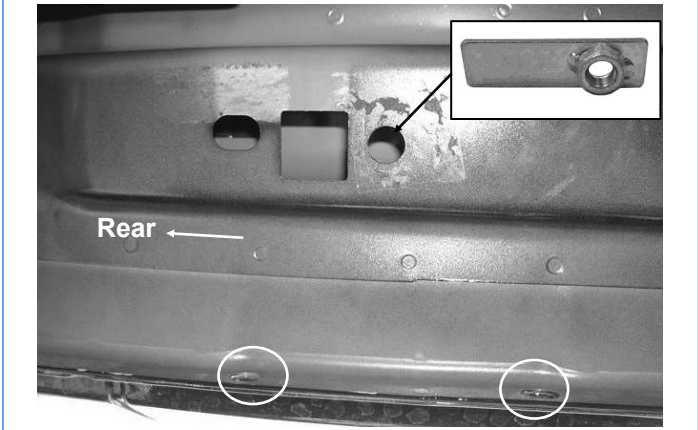

(Fig 3) Driver Side Center & Rear Mounting Location (Vehicles with open mounting location)

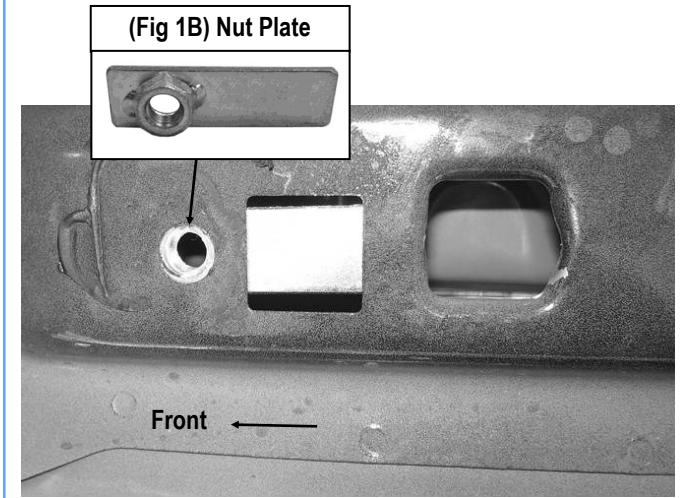

(Fig 1A) Driver Side Front Mounting Location (Vehicles with open mounting location)

STEP 2

B. Vehicles with factory threaded hole in floor panel:

Locate the front ,center and rear mounting locations, (**Fig 4 & 5**). Continue to **Step 3**.

iBoard®

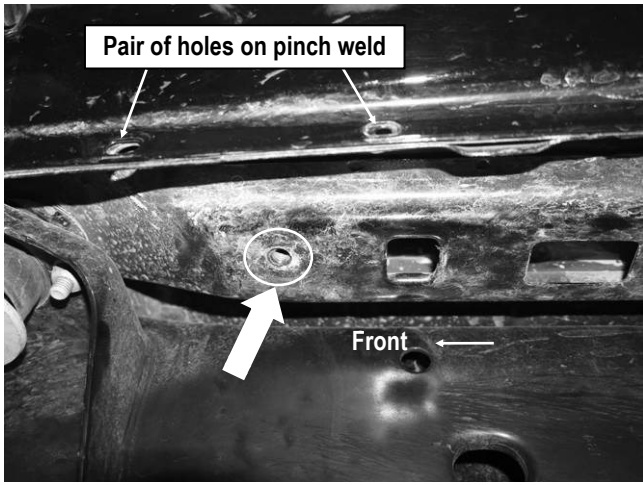

(Fig 4) Driver Side Front Mounting Location
(Vehicles with factory threaded hole in floor panel)

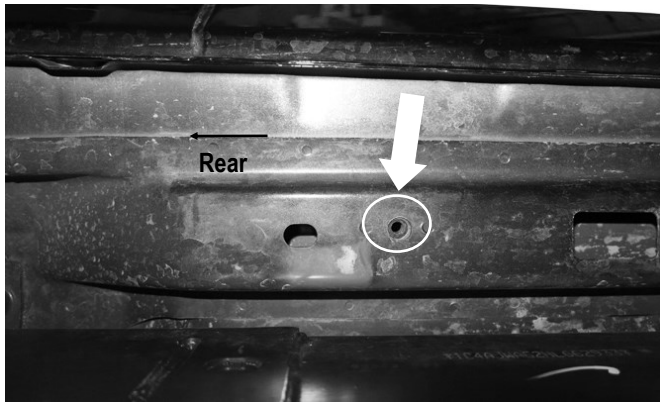

(Fig 5) Driver Side Center & Rear Mounting Location
(Vehicles with factory threaded hole in floor panel)

STEP 3

Assemble (3) Driver Side Mounting Brackets and Driver Side Support Brackets (Fig 6-8). Do not fully tighten hardware at this time.

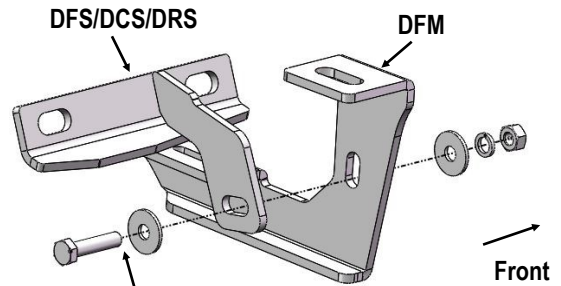

- (1) M8X1.25-35mm Hex Bolt
- (2) M8 Large Flat Washers
- (1) M8 Lock Washer
- (1) M8 Hex Nut

(Fig 6) Driver Front Mounting Bracket Assembly

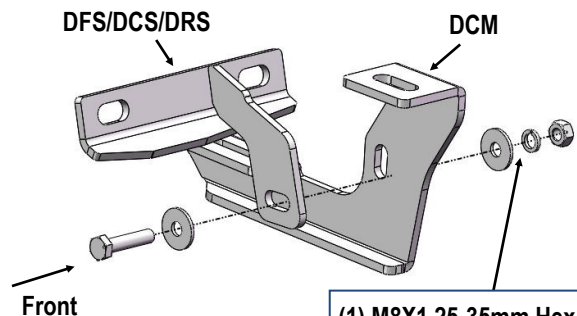

- (1) M8X1.25-35mm Hex Bolt
- (2) M8 Large Flat Washers
- (1) M8 Lock Washer
- (1) M8 Hex Nut

(Fig 7) Driver Center Mounting Bracket Assembly

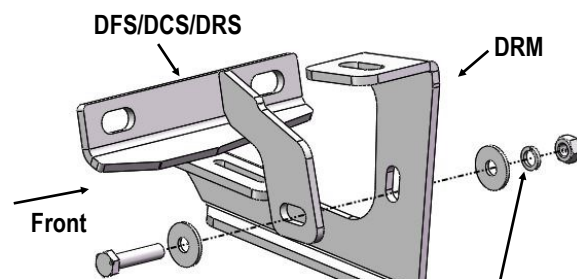

- (1) M8X1.25-35mm Hex Bolt
- (2) M8 Large Flat Washers
- (1) M8 Lock Washer
- (1) M8 Hex Nut

(Fig 8) Driver Rear Mounting Bracket Assembly

iBoard®

STEP 4

On Driver Side Front Mounting Location. Attach the Driver Support Bracket (DFS/DCS/DRS) on the **back** of the pinch weld. Secure to the (2) pairs of holes on the pinch weld with (2) M6X1-25mm Hex Bolts, (4) M6 Large Flat Washers & (2) M6 Nylon Lock Nuts (Fig 9 & 10). Don't fully tighten hardware at this time.

- (2) M6x1-25mm Hex Bolts
- (4) M6 Large Flat Washers
- (2) M6 Nylon Lock Nuts

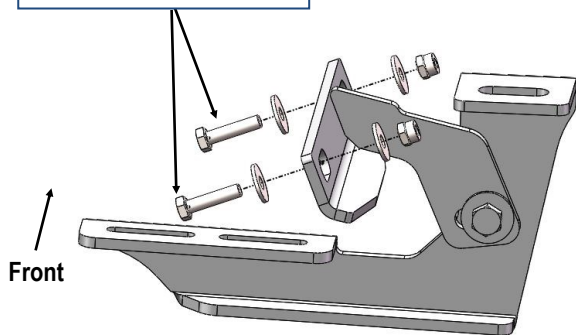

(Fig 9) Driver Front Support Bracket Installed

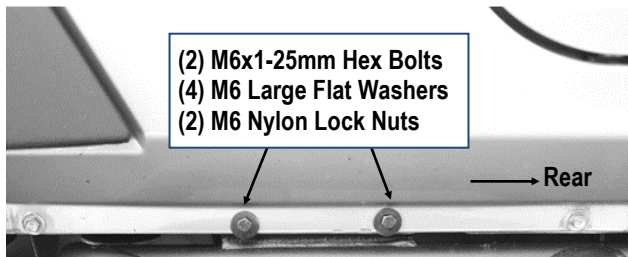

(Fig 10) Driver Front Support Bracket Installed

STEP 5

Vehicles with open mounting location:
Bolt the Driver Front Mounting Bracket to the M10 Nut Plate with (1) M8X1.25-35mm Hex Bolt, (1) M8 Lock Washer and (1) M8 Large Flat Washer, (Fig 11). Do not fully tighten hardware at this time.

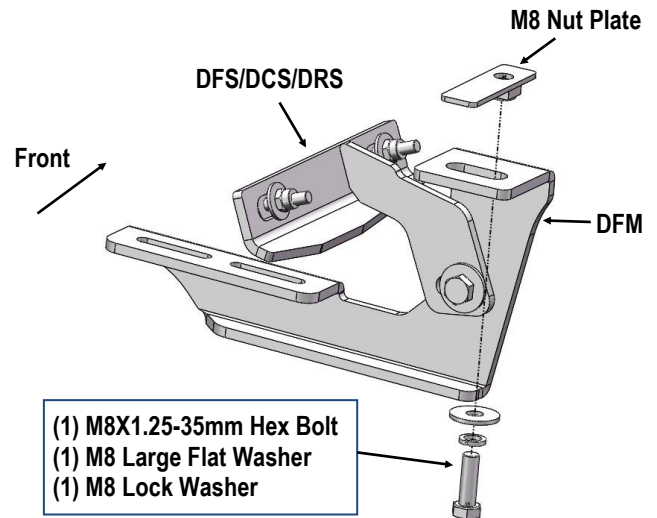

(Fig 11) Driver Front Mounting Bracket Installed
(Vehicles with open mounting location)

STEP 6

Vehicles with factory threaded hole in floor panel:
Bolt the Mounting Bracket to the threaded hole in the floor panel with (1) M8X1.25-35mm Hex Bolt, (1) M8 Large Flat Washer, (1) M8 Lock Washer (Fig 12). Do not fully tighten hardware at this time.

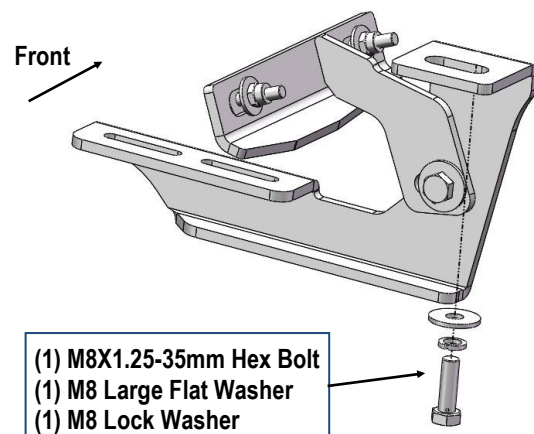

(Fig12) Driver Front Mounting Bracket Installed
(Vehicles with factory threaded hole in floor panel)

iBoard®

STEP 7

Repeat **Steps 4-6** to install the Assembled Driver Center & Rear Mounting Bracket. Do not fully tighten hardware at this time.

STEP 8

Select a Running Board. Slip (3) M6x1-20mm Square Head Bolts into each bottom channel (**Fig 13**). Carefully position the Running Board onto the (3) Mounting Brackets.

IMPORTANT: Do not slide the Running Board on the Brackets or the bottom surface of the board will be damaged. Attach the Running Board to each Mounting Bracket with (2) M6x1-20mm Square Head Bolts, (2) M6 Large Flat Washers and (2) M6 Nylon Lock Nuts (**Fig 14**). Do not fully tighten at this time.

M6X1-20mm Square Head Bolts

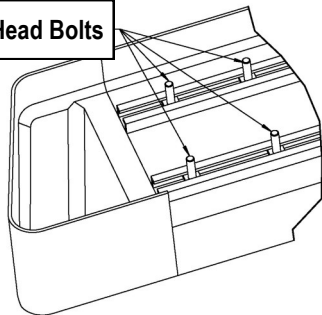

(Fig 13) Slip M6X1-20mm Square Head Bolts Into The Bottom Channels

(2) M6X1-20mm Square Head Bolts
(2) M6 Large Flat Washers
(2) M6 Nylon Lock Nuts

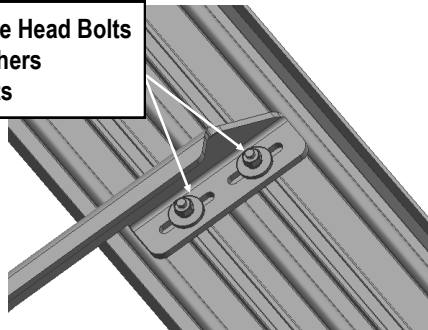

(Fig 14) Running Board Installed Onto Mounting Bracket

STEP 9

Level and adjust the Running Board and fully tighten all hardware.

Important: Please follow the recommended Tightening Torques shown in the table on page 1. Don't over tighten, or the nuts/bolts will be damaged.

STEP 10

Repeat **Steps 1-9** for the other side Running Board installation. The installation is completed.

Attention

Do periodic inspections to the installation to make sure that all hardware is secure and tight.

In order to protect your bars/boards, please use only mild soap/non-abrasive products for cleaning.