

# iBoard®

## iBoard® by APS

PART#: IB-R115

READ INSTRUCTIONS CAREFULLY BEFORE STARTING INSTALLATION. REMOVE CONTENTS FROM BOX AND VERIFY ALL PARTS ARE PRESENT. ASSISTANCE IS RECOMMENDED.

\*ROCKER PANEL MOUNT  
\*NO DRILLING REQUIRED

Fastener Size	Tightening Torque (ft-lbs)	Required
6mm	6-7	√
8mm	16-18	√
10mm	31-32	√
12mm	56-58	X
14mm	92-94	X

Item	QTY	Description	Item	QTY	Description
1#	1	Driver Front Mounting Bracket	13#	8	M10X1.5-30mm Hex Bolts
2#	1	Driver Front Support Bracket	14#	16	M10 Flat Washers
3#	1	Passenger Front Mounting Bracket	15#	8	M10 Nylon Lock Nuts
4#	1	Passenger Front Support Bracket	16#	8	M8X1.25-35mm Hex Bolts
5#	1	Driver Center Mounting Bracket	17#	8	M8 Large Flat Washers
6#	2	Driver Center Support Brackets	18#	8	M8 Lock Washers
7#	1	Passenger Center Mounting Bracket	19#	16	M6X1-25mm Hex Bolts
8#	2	Passenger Center Support Brackets	20#	48	M6 Large Flat Washers
9#	2	Driver Rear Mounting Brackets	21#	16	M6 Lock Washers
10#	1	Driver Rear Support Bracket	22#	16	M6 Hex Nuts
11#	2	Passenger Rear Mounting Brackets	23#	16	M6X1-20mm Square Head Bolts
12#	1	Passenger Rear Support Bracket	24#	16	M6 Nylon Lock Nuts

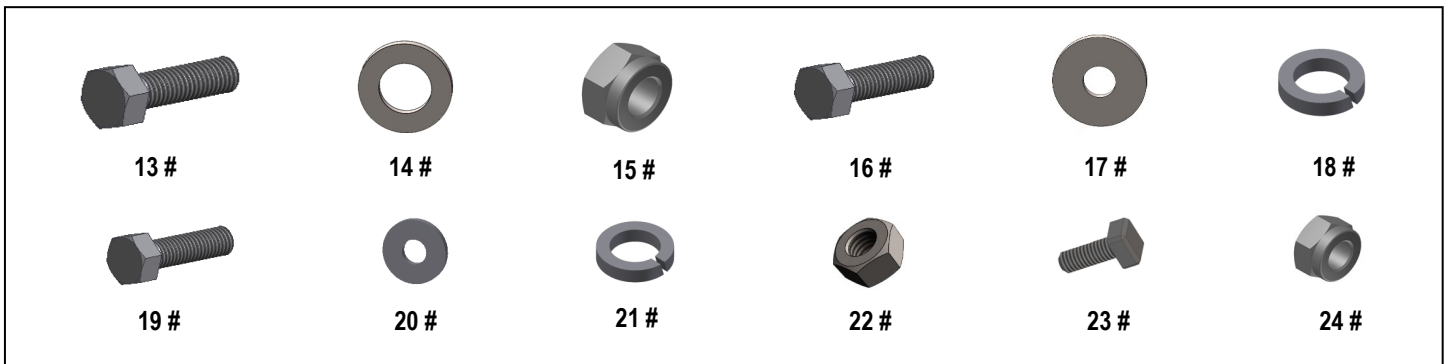

Customer Support: [info@iboardauto.com](mailto:info@iboardauto.com)

# iBoard®

Driver

Front

Passenger

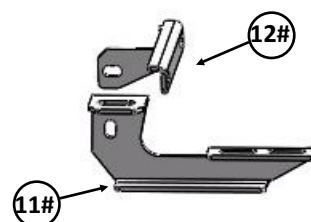
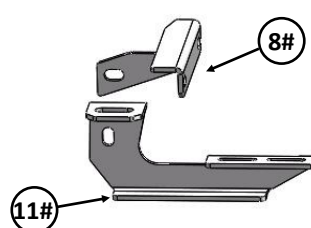
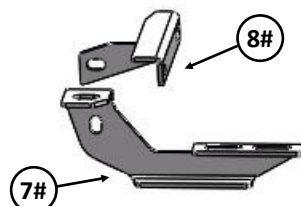
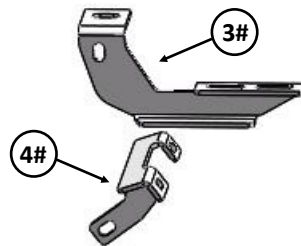
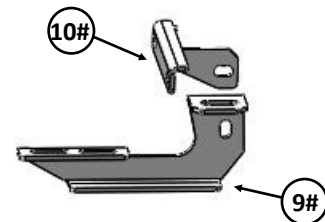
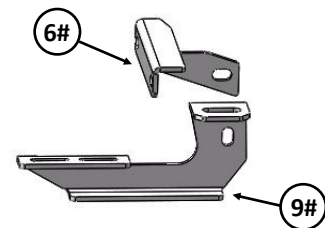
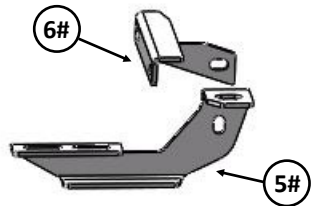
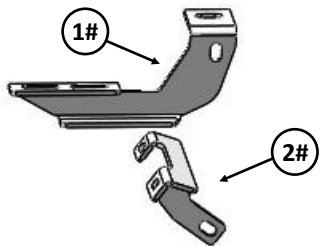

# iBoard®

## STEP 1

Start the installation under the driver side of the vehicle. Locate (4) mounting points on the vehicle, (Fig 1). Find the threaded insert located in between the first pair of holes along the pinch weld, (Fig 2).

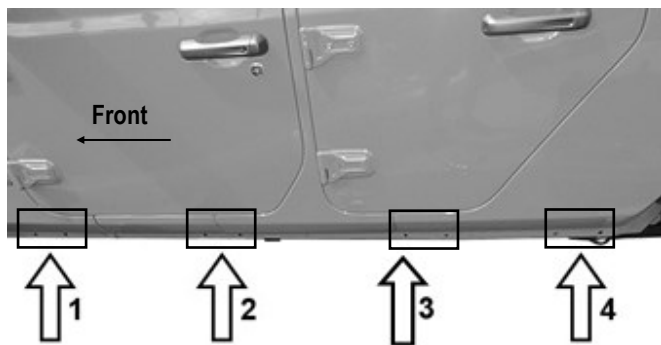

(Fig 1) Driver Side (4) Mounting Locations On The Vehicle

## STEP 2

Start from the driver side front of the vehicle, (Fig 2). Assemble the Driver Front Mounting Bracket and Driver Front Support Bracket with: (1) M10X1.5-30mm Hex Bolt, (2) M10 Flat Washers, (1) M10 Nylon Lock Nut, (Fig 3). Do not fully tighten hardware at this time.



(Fig 2) Driver Side Front Mounting Location

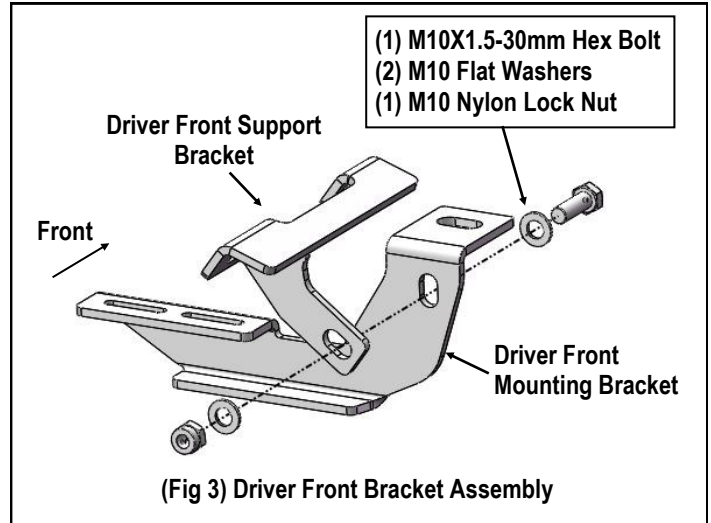

(Fig 3) Driver Front Bracket Assembly

## STEP 3

Attach the assembled Driver Side Front Brackets to the vehicle with: (1) M8X1.25-35mm Hex Bolt, (1) M8 Lock Washer, (1) M8 Large Flat Washer, (2) M6X1-25mm Hex Bolts, (4) M6 Large Flat Washers and (2) M6 Nylon Lock Nuts, (Fig 4). Don't fully tighten the hardware at this time.

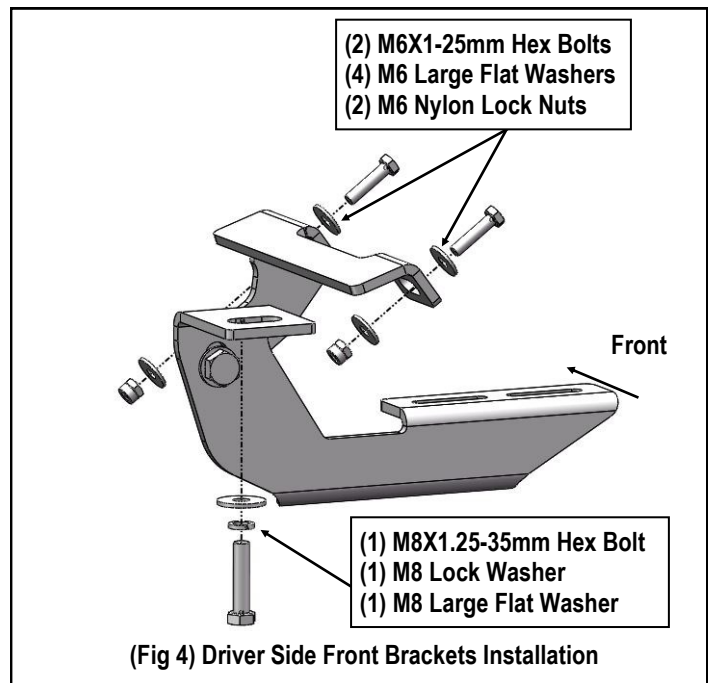

(Fig 4) Driver Side Front Brackets Installation

# iBoard®

## STEP 4

Move to driver side 2nd & 3rd & 4th Mounting Locations, (**Fig 1**). Repeat **Steps 1-3** to assemble and install 2nd & 3rd & 4th brackets, (**Figs 6-8**). Don't fully tighten the hardware at this time.



(Fig 5) Driver Side (3) Support Brackets Are Different

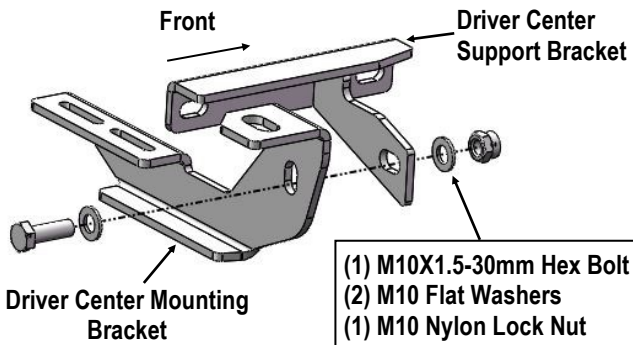

(Fig 6) Driver Side 2nd Bracket Assembly

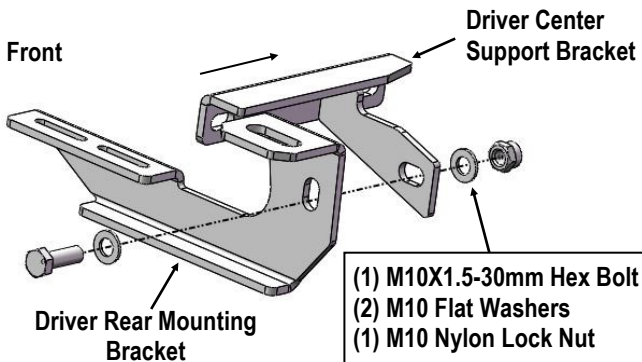

(Fig 7) Driver Side 3rd Brackets Assembly

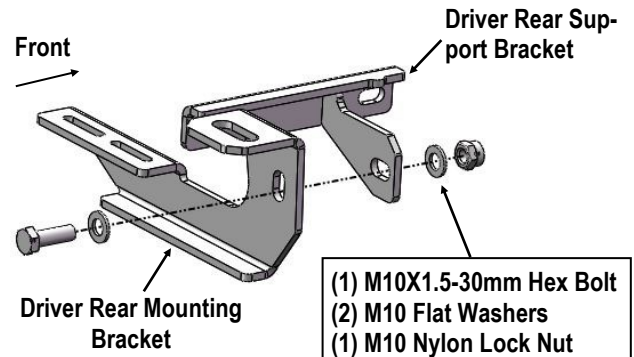

(Fig 8) Driver Side 4th Brackets Assembly

## STEP 5

Select a Running Board. Slip (4) M6x1-20mm Square Head Bolts into each bottom channel (**Fig 9**). Carefully position the Running Board onto the (4) Mounting Brackets.

**IMPORTANT:** Do not slide the Running Board on the Brackets or the bottom surface of the board will be damaged. Attach the Running Board to each Mounting Bracket with (2) M6x1-20mm Square Head Bolts, (2) M6 Large Flat Washers and (2) M6 Nylon Lock Nuts (**Fig 10**). Do not fully tighten at this time.

M6X1-20mm Square Head Bolts

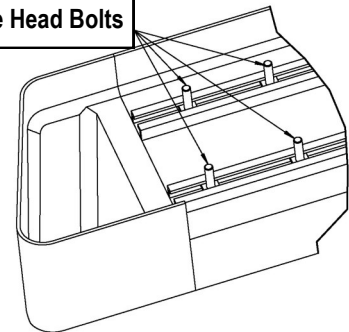

(Fig 9) Slip M6X1-20mm Square Head Bolts Into The Bottom Channels

# iBoard®

- (2) M6X1-20mm Square Head Bolts
- (2) M6 Large Flat Washers
- (2) M6 Nylon Lock Nuts

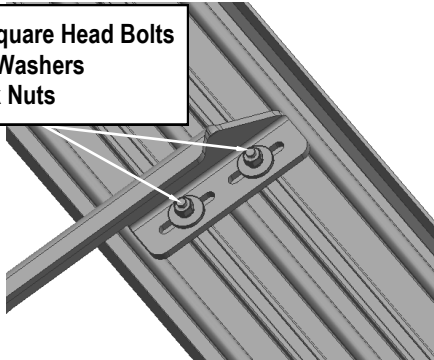

(Fig 10) Running Board Installed Onto Mounting Bracket

## STEP 6

Level and adjust the Running Board and fully tighten all hardware.

**Important:** Please follow the recommended Tightening Torques shown in the table on page 1. Don't over tighten, or the nuts/bolts will be damaged.

## STEP 7

Repeat **Steps 1-6** for the other side Running Board installation. The installation is completed .

### Attention

Do periodic inspections to the installation to make sure that all hardware is secure and tight.

In order to protect your bars/boards, please use only mild soap/non-abrasive products for cleaning.