

# iBoard®



Scan for  
Installation Video

## iBoard® by APS

PART#: IB-217C&H

READ INSTRUCTIONS CAREFULLY BEFORE STARTING INSTALLATION. REMOVE CONTENTS FROM BOX AND VERIFY ALL PARTS ARE PRESENT. ASSISTANCE IS RECOMMENDED.

\*ROCKER PANEL MOUNT  
\*DRILLING IS REQUIRED

Fastener Size	Tightening Torque (ft-lbs)	Required
6mm	6-7	X
8mm	16-18	√
10mm	31-32	√
12mm	56-58	√
14mm	92-94	X

### PART LIST

#### Driver Side Step Bar

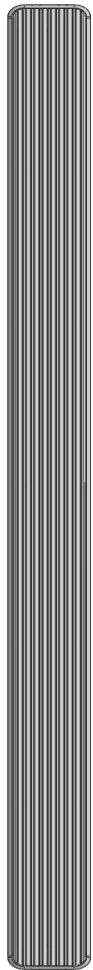

Front



#### Passenger Side Step Bar

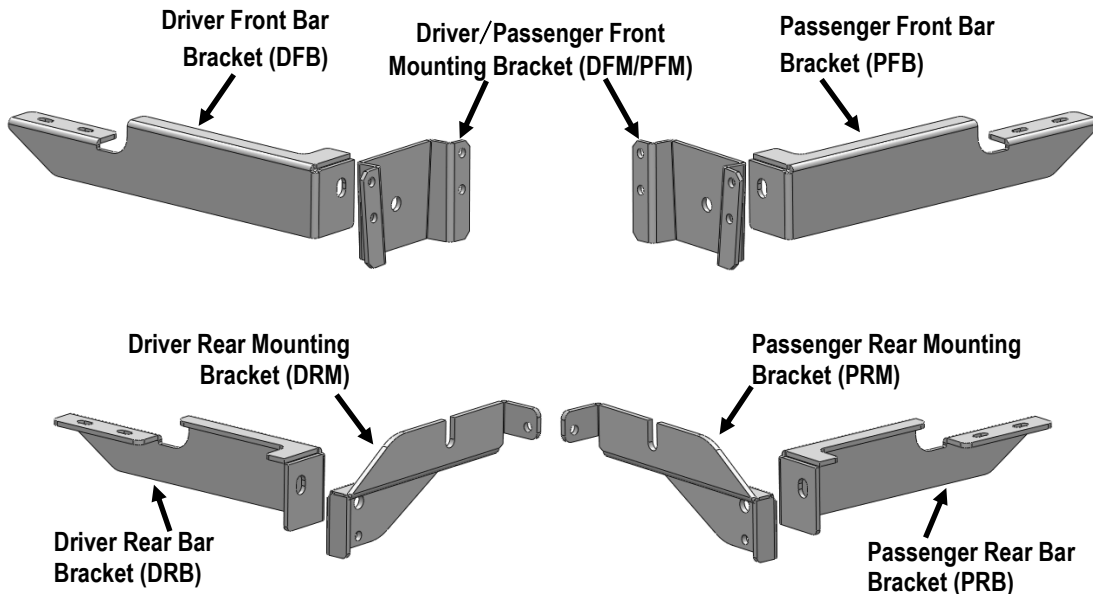
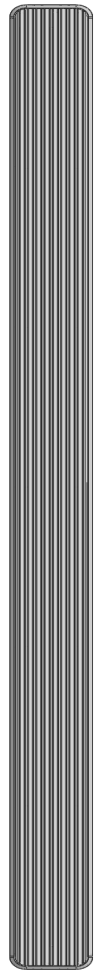



Customer Support: [info@iboardauto.com](mailto:info@iboardauto.com)





Hardware Package A (For Bracket Installation)					
Item	QTY	Description	Item	QTY	Description
1#	4	M12X1.75-40mm Hex Bolts	5#	10	M10X1.5-25mm Hex Bolts
2#	8	M12 Large Flat Washers	6#	10	M10 Flat Washers
3#	4	M12 Lock Washers	7#	10	M10 Lock Washers
4#	4	M12 Hex Nuts	8#	1	M10 Hand Screw Tap

  
1#

  
2#

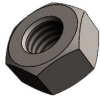
  
3#

  
4#

  
5#

  
6#

  
7#

  
8#

Hardware Package B (For Stainless Steel Step Bar Installation)					
Item	QTY	Description	Item	QTY	Description
1#	8	M8X1.25-35mm Carriage Bolts	3#	8	M8 Nylon Lock Nuts
2#	8	M8 Large Flat Washers	4#	4	Sliders (Packed with Step Bars)

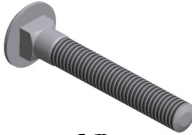
  
1 #

  
2 #

  
3 #

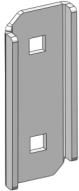
  
4 #



## STEP 1

Start installation from the driver side of the vehicle.

Select the Driver Front Mounting Bracket (**DFM**) and the Driver Front Bar Bracket (**DFB**). Assemble with the included (1) M12X1.75-40mm Hex Bolt, (2) M12 Large Flat Washer, (1) M12 Lock Washer and (1) M12 Hex Nut, (**Fig 1**). Do not fully tighten hardware at this time.

Repeat to assemble Driver Side Rear Mounting Brackets, (**Fig 2**).

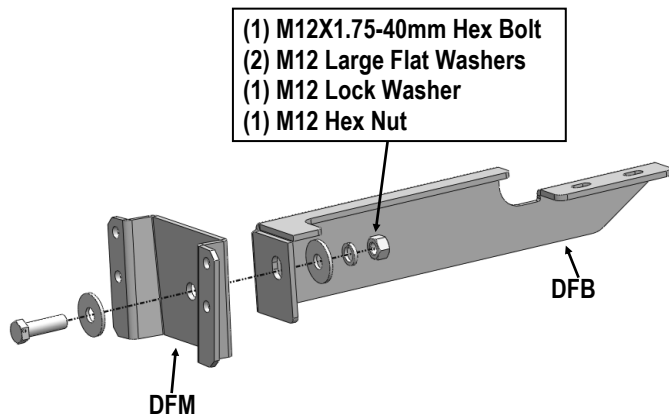

(Fig 1) Driver Front Mounting Bracket Assembly

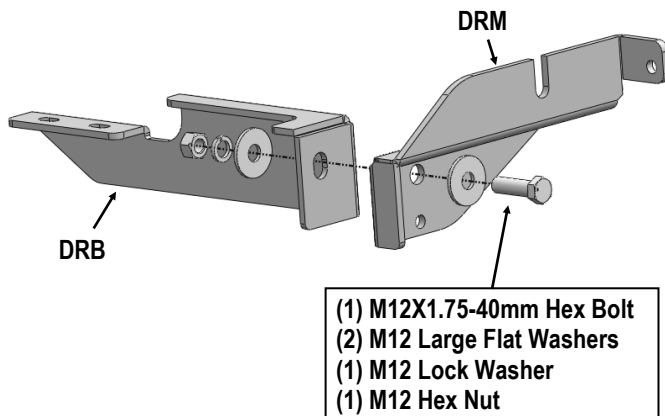

(Fig 2) Driver Rear Mounting Bracket Assembly

## STEP 2

Once all (2) Driver side mounting brackets are assembled, then proceed to the Step Bar installation. (**Figs 3 & 4**)

- (1) Select (1) Slider and (2) M8X1.25-35mm Carriage Bolts;
- (2) Install (2) M8X1.25-35mm Carriage Bolts in (1) Slider.
- (3) Slide the Slider (with carriage bolts) to the **Step Bar**.
- (4) Repeat to install the other (1) slider to the step bar.

(5) Attach the Step Bar (with the Sliders) onto the installed mounting brackets. Position the Sliders to the installed brackets. Secure the Step Bar to the installed Brackets by using (4) M8 Large Flat Washers and (4) M8 Nylon Lock Nuts and (2) Sliders, (**Fig 4**). Do not fully tighten hardware at this time.

**Note:** The Sliders are packed with the Step Bars.

Level and adjust the Step Bar and fully tighten all hardware.

## STEP 3

Place the side step assembly on to the vehicle frame. Slid the Mounting Bracket on the shackle bolt (**NOTE: DO NOT REMOVE THIS BOLT**) on the frame, until the step bar on the proper position, and tighten the shackle bolt and other M12 bolts until the rear mounting bracket is held in place, (**Fig 5**).

Hold up the front end of the Step Bar assembly. Make sure the Step Bar is properly aligned with the vehicle body and level, and then mark the mounting holes on the vehicle frame.

Drill holes on the vehicle frame according to the marks using the 8.5mm drill bit. **NOTE:** On some models it may be necessary to locate the front mounting bracket at an angle to keep away from the OEM holes on the frame, (**Fig 5**).

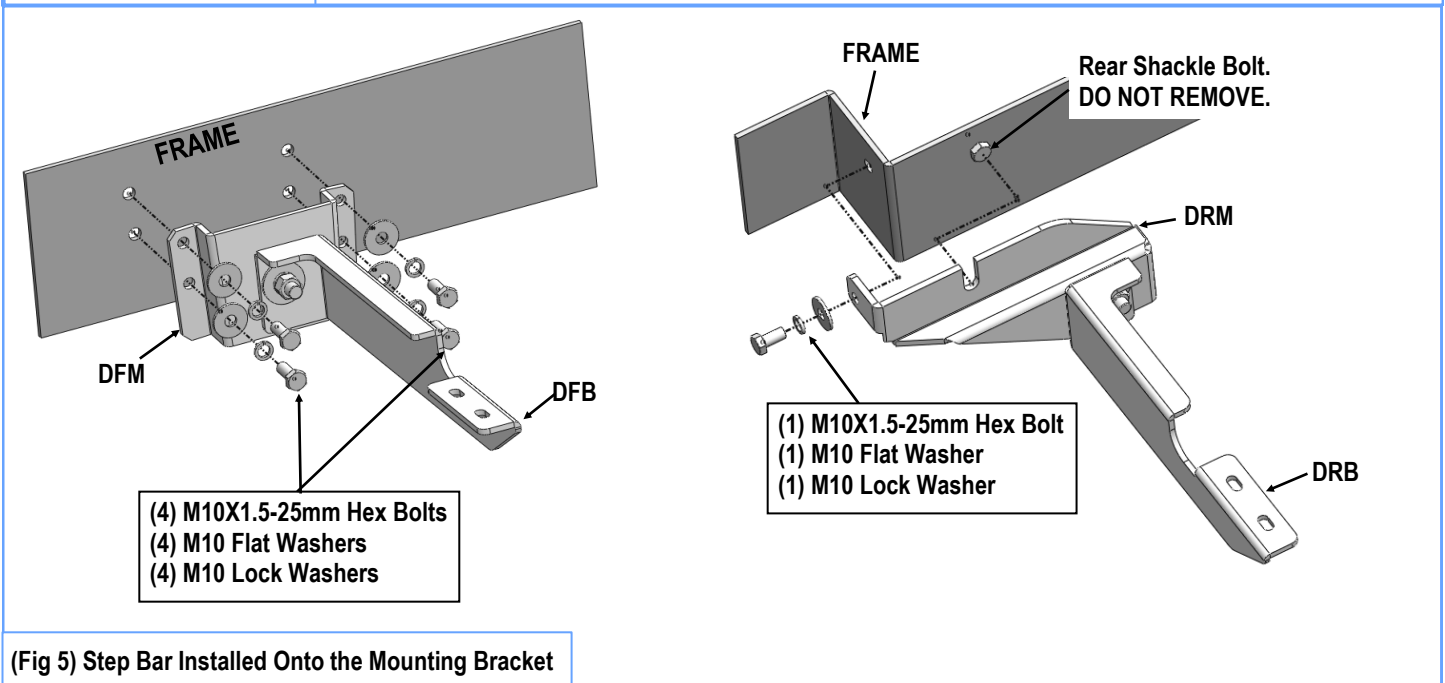
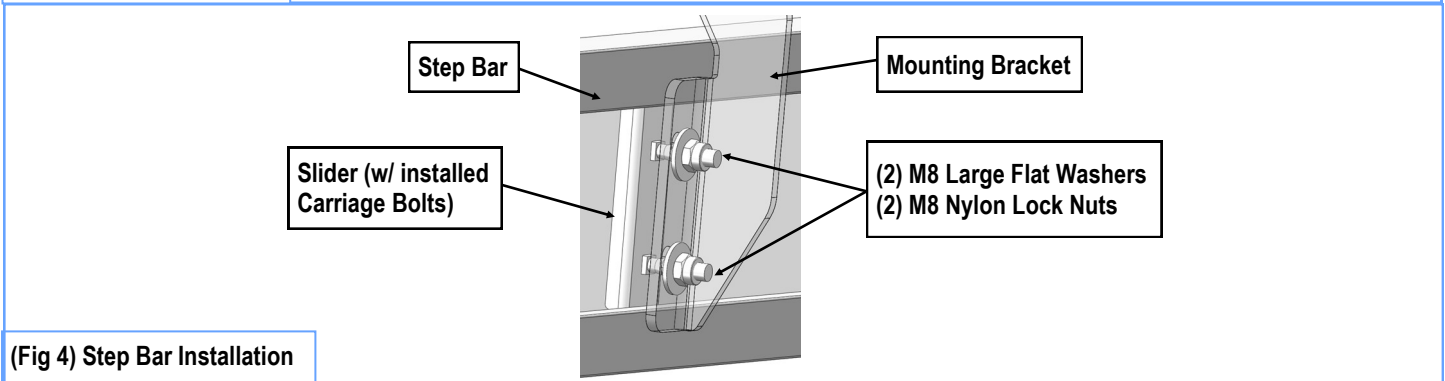
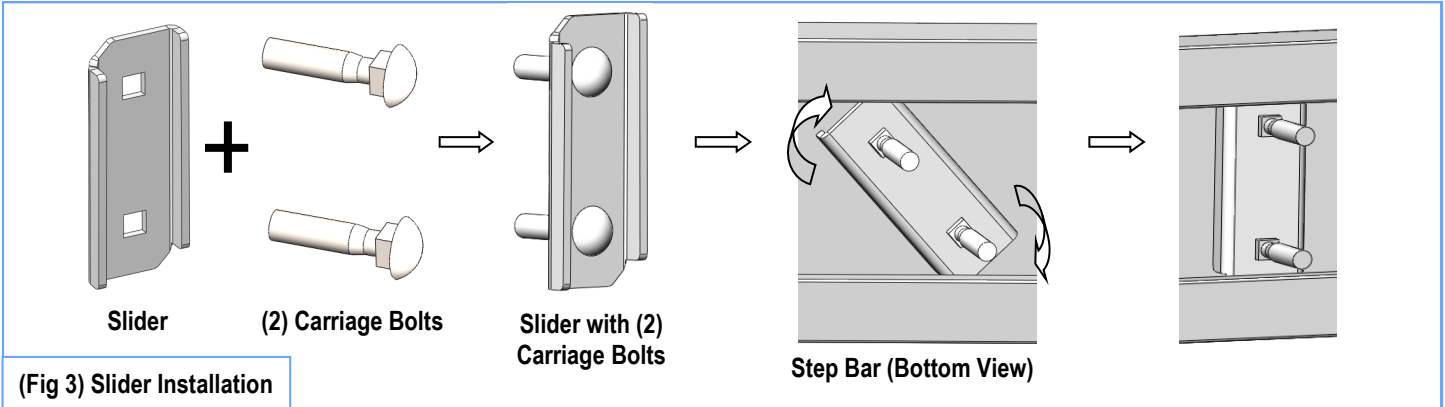



## STEP 4

Tap (4) 10mm threads on to the drilled holes with the supplied 10mm Hand Screw Tap.

Secure the Driver Front Mounting Bracket to the threads holes (which were taped on **Step 5**) on the frame, using (4) M10X1.5-25mm Hex Bolts, (4) M10 Lock Washers and (4) M10 Flat Washers. Secure the Driver Rear Mounting Bracket with (1) M10X1.5-25mm Hex Bolt, (1) M10 Lock Washer and (1) M10 Flat Washer, (**Fig 5**). Do not fully tighten at this time.

## STEP 5

Level and adjust the Step Bar and fully tighten all hardware.

## STEP 6

Repeat **Steps 1-5** for other side Step Bar installation. The installation is completed.

### Attention

**Do periodic inspections to the installation to make sure that all hardware is secure and tight.  
In order to protect your bars/boards, please use mild soap/non-abrasive products for cleaning only.**