

iBoard®

iBoard® by APS

PART#: IB-192

READ INSTRUCTIONS CAREFULLY BEFORE STARTING INSTALLATION. REMOVE CONTENTS FROM BOX AND VERIFY ALL PARTS ARE PRESENT. ASSISTANCE IS RECOMMENDED.

*BODY FRAME MOUNT

*DRILLING IS REQUIRED/ CUTTING IS REQUIRED

Fastener Size	Tightening Torque (ft-lbs)	Required
6mm	6-7	√
8mm	16-18	√
10mm	31-32	√
12mm	56-58	X
14mm	92-94	X

PART LIST

Front

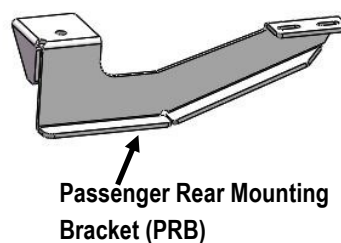
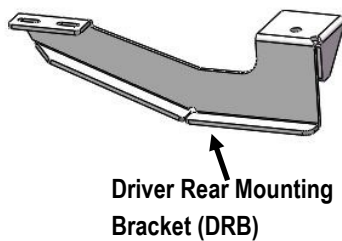
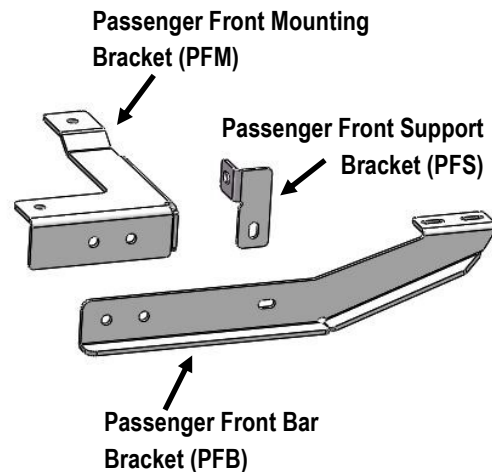
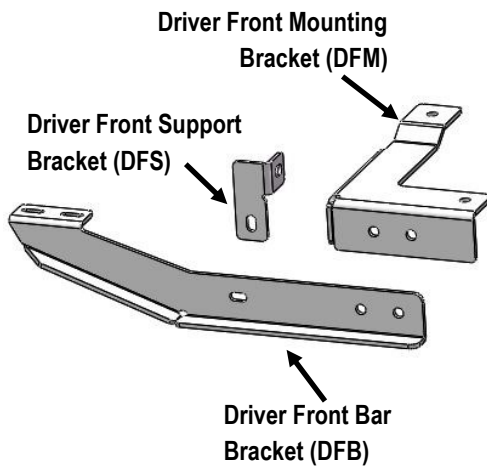

Customer Support: info@iboardauto.com

iBoard®

Hardware Package A (For Bracket Installation)

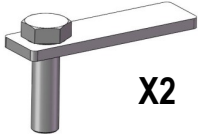

X2

M10X35 Bolt Plate

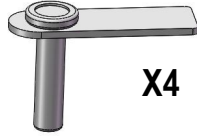

X4

M10X40 Bolt Plate



X6

M10X1.5-35mm Hex Bolt



X18

M10 Large Flat Washer



X10

M10 Lock Washer

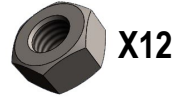

X12

M10 Hex Nut



X2

M8X1.25-35mm Hex Bolt



X4

M8 Large Flat Washer



X2

M8 Lock Washer

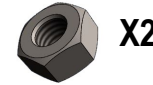

X2

M8 Hex Nut

Hardware Package B (For Aluminum Step Bar Installation Only, Not Supply to Stainless Steel Step Bar)

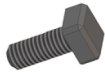

X8

M6X1-20mm Square Head Bolt



X8

M6 Large Flat Washer



X8

M6 Nylon Lock Nut

Hardware Package C (For Stainless Steel Step Bar Installation Only, Not Supply to Aluminum Step Bar)

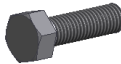

X8

M6X1-20mm Hex Bolt



X8

M6 Lock Washer



X8

M6 Flat Washer

STEP 1

Start installation from the driver side front of the vehicle. Locate the (3) factory holes (1 round and 2 oval holes).

In the bottom of the left front floor panel, **(Fig 1)**. Insert (1) M10X40 Bolt Plate into the smaller, (inner), oval hole and feed the threaded end back out through the larger, (outer), oval hole, **(Fig 2)**. Next, insert (1) M10X40 Bolt Plate into the oval hole in the bottom of the inner frame channel, **(Fig 3)**.

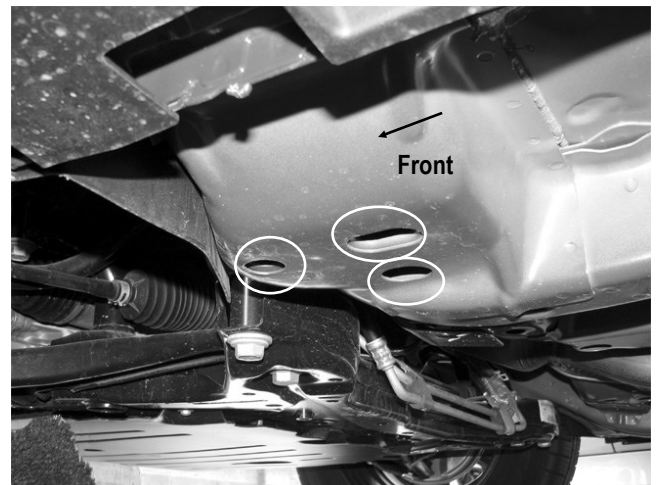

(Fig 1) Driver Side Front Mounting Location Pictured

iBoard®

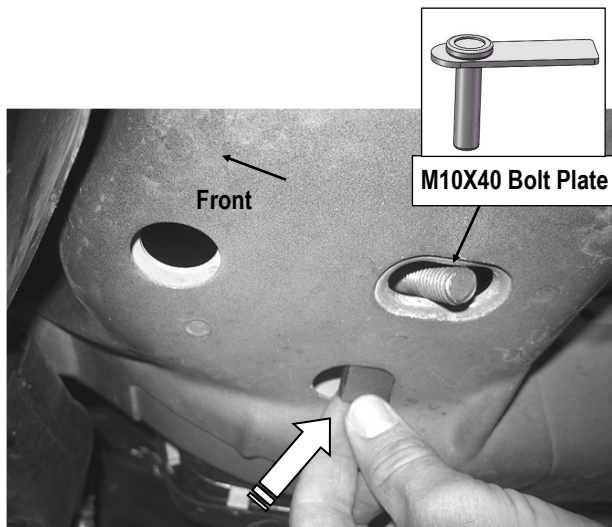

(Fig 2) Insert (1) M10X40 Bolt Plate Into The Inner Small Oval Hole

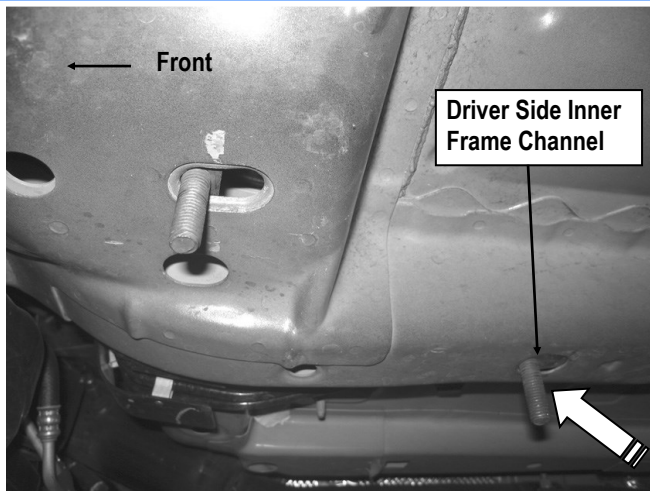

(Fig 3) Insert (1) M10X40 Bolt Plate Into The Bottom Of The Inner Frame Channel

STEP 2

Select the Driver Front Mounting Bracket (**DFM**) and the Driver Front Bar Bracket (**DFB**). Bolt the Bar Bracket to the back of the Mounting Bracket with the included (2) M10X1.5-35mm Hex Bolts, (4) M10 Large Flat Washers, (2) M10 Lock Washers and (2) M10 Hex Nuts, (**Fig 4**). Do not fully tighten hardware at this time.

Then, attach the assembled driver side front Bracket to the (2) M10X40 Bolt Plates with the included (2) M10 Large Flat Washers, (2) M10 Lock Washers and (2) M10 Hex Nuts, (**Fig 5**). Do not fully tighten hardware at this time.

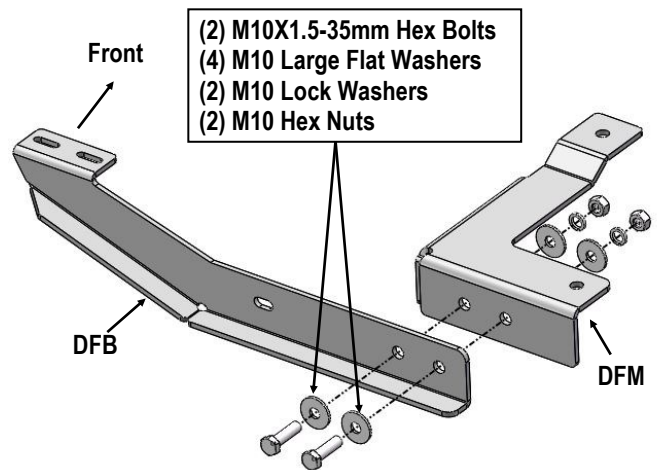

(Fig 4) Driver Front Mounting Bracket Assembly

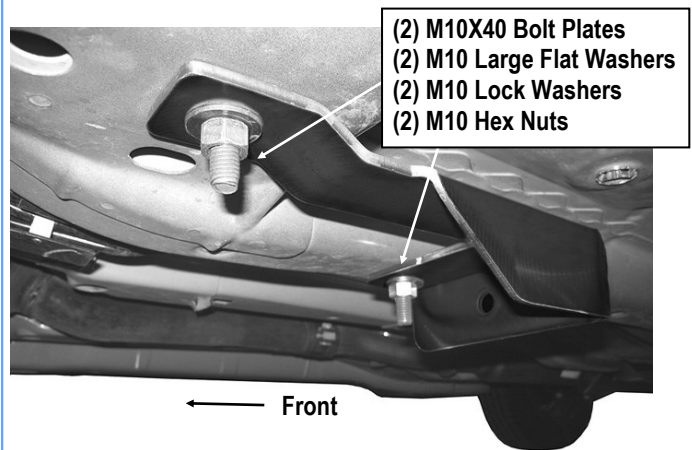

(Fig 5) Driver Front Mounting Bracket Installation

STEP 3

Next, select the Driver Front Support Bracket (**DFS**), (**Fig 6**). Attach the Support Bracket to the front side of the Driver Front Bar Bracket with (1) M10X1.5-35mm Hex Bolt, (2) M10 Large Flat Washers, (1) M10 Lock Washer and (1) M10 Hex Nut, (**Fig 6**). Do not fully tighten hardware at this time.

iBoard®

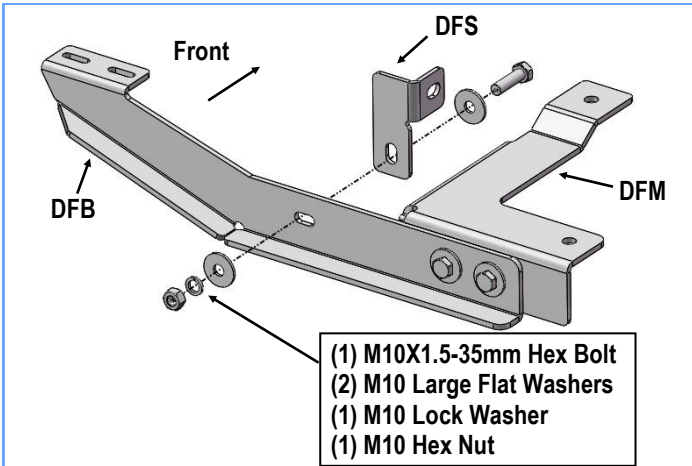

(Fig 6) Driver Front Support Bracket Assembly

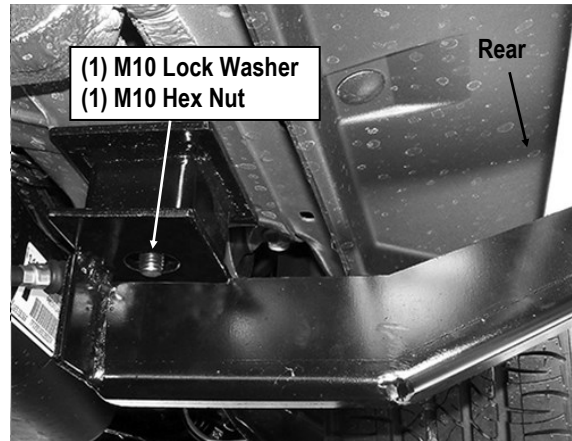

(Fig 8) Driver Rear Mounting Bracket Installation

STEP 4

Move to driver side rear mounting location. Locate the large oval slot in the floor panel. Insert (1) M10x35 Bolt Plate into the slot, (Fig 7). **NOTE:** Rotate the Bolt Plate so that the plate is across, not inline with the oval hole.

Attach the Driver Rear Mounting Bracket (DRB) to the M10x35 Bolt Plate with (1) M10 Lock Washer and (1) M10 Hex Nut, (Fig 8). **NOTE:** A deep socket is required to tighten the Hex Nut up into the Bracket. Do not fully tighten hardware at this time.

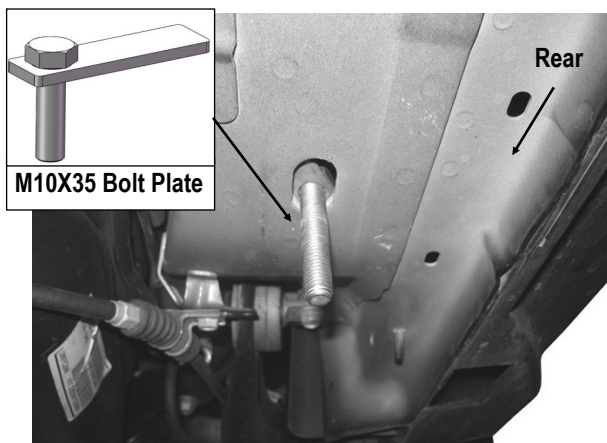

(Fig 7) Insert (1) M10x35 Bolt Plate Into The Slot

STEP 5

Once all (2) mounting brackets are installed, then proceed to the Step Bar installation. According to the style of Step Bar proceed to the correct installation STEPS.

Note: Aluminum Step Bar refer to STEP 6; Stainless Steel Step Bar skip to STEP 7.

STEP 6

Aluminum Step Bar Installation:

Select a **Aluminum Step Bar**. Slip (2) M6x1-20mm Square Head Bolts into each bottom channel (Fig 9). Carefully position the Step Bar onto the (2) Mounting Brackets.

IMPORTANT: Do not slide the Step Bar on the Brackets or the bottom surface of the board will be damaged. Attach the Step Bar to each Mounting Brackets with (2) M6x1-20mm Square Head Bolts, (2) M6 Large Flat Washers and (2) M6 Nylon Lock Nuts, (Fig 10). Do not fully tighten at this time.

iBoard®



(Fig 9) Slip M6X1-20mm Square Head Bolts Into The Bottom Channels



(Fig 11) Slide & line up the U-Slider with the installed mounting brackets along bottom channel

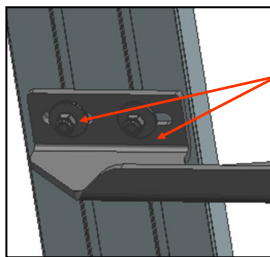

(2) M6X1-20mm Square Head Bolts
(2) M6 Large Flat Washers
(2) M6 Nylon Lock Nuts
IMPORTANT: TORQUE FOR 6MM FASTNERS MUST LESS THAN 6-7 FT-LBS OR THE FASTNERS WILL BE DAMAGED!

(Fig 10) Running Board Installed Onto Mounting Bracket

(2) M6X1-20mm Hex Bolts
(2) M6 Large Flat Washers
(2) M6 Lock Washers
IMPORTANT: TORQUE FOR 6MM FASTNERS MUST LESS THAN 6-7 FT-LBS OR THE FASTNERS WILL BE DAMAGED!

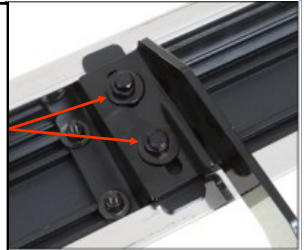

(Fig 12) Step Bar Installed on Bracket Installed (Example)

STEP 7

Stainless Steel Step Bar Installation:

Select a **Stainless Steel Step Bar** (with the U-Sliders installed on the Bar). Loosen the U-Sliders, reposition the U-Sliders onto the board according to the (2) Installed Mounting Brackets location, (Fig 11). Re-secure the U-Sliders on the Step Bar. Attach the Step Bar to the installed Mounting Brackets with (4) M6X1-20mm Hex Bolts, (4) M6 Large Flat Washers & (4) M6 Lock Washers, (Fig 12). Do not fully tighten hardware at this time.

STEP 8

With the Running board Bracket hardware loose, pull the Brackets outward away from the vehicle for proper clearance.

STEP 9

Line up the Driver Front Support Bracket (**DFS**) with the back of the pinch weld, (Fig 13). Push the Support Bracket up as high as possible to where the pinch weld meets the floor panel. Do not fully tighten hardware.

Check the Running Board for level. Once properly aligned and adjusted, tighten all hardware. **IMPORTANT:** If the Support Bracket is too low and close to the edge of the pinch weld, loosen the Support Bracket and front Bracket hardware. Push the Bracket and Support Bracket up a little into position against the floor panel and away from the edge of the pinch weld, (Fig 13). Level and adjust the Running Board properly and tighten all hardware.

iBoard®

STEP 10

Use the hole in the Support Bracket as a guide to mark the drilling location on the back of the pinch weld, (**Fig 13**). Once you have marked the location, temporarily remove the Sidebar, the front Mounting Bracket and Support Bracket. Remove the plastic clips securing the plastic rocker cover to the rocker panel.

Use a 5/16" drill bit and carefully drill the marked location.

NOTE: The plastic rocker panel cover may need to be trimmed to clear the hex bolt for the Support Bracket. **IMPORTANT:** Any cutting or drilling tool may break or shatter. Government regulations require safety glasses & equipment at all times when cutting or drilling.

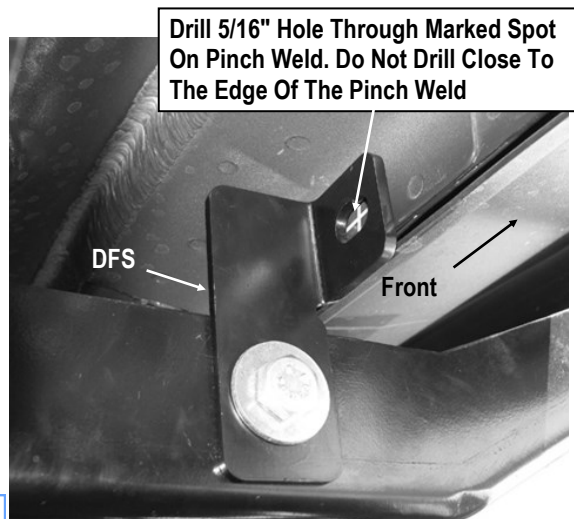
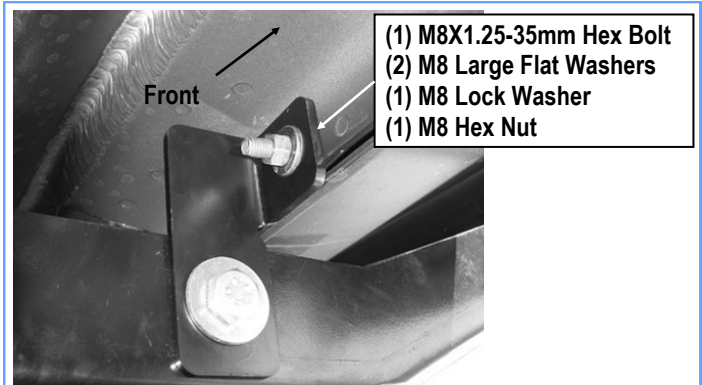

Fig 13

STEP 11

Re-install the driver side front Mounting Bracket and Support Bracket. Attach the Support Bracket to the pinch weld with (1) M8X1.25-35mm Hex Bolt, (2) M8 Large Flat Washers, (1) M8 Lock Washer and (1) M8 Hex Nut, (**Fig 14**). **NOTE:** Insert the M8 Hex Bolt with (1) M8 Large Flat Washer through the pinch weld first, then through the Bracket.

Cut the rocker panel cover as required and reinstall the cover with the factory plastic clips. Reinstall the Running Board.



(Fig 14) Driver Front Support Bracket Installation

STEP 12

Level and adjust the Running Board and fully tighten all hardware.

STEP 13

Repeat **Steps 1-13** for other side Running Board installation. **The installation is completed.**

Attention

Do periodic inspections to the installation to make sure that all hardware is secure and tight.

In order to protect your bars/boards, please use only mild soap/non-abrasive products for cleaning.