

iRunning Board Installation Instruction

Application: For 2020 Jeep Gladiator

Rev:20191101

PARTS LIST

Item	QTY	Description	Item	QTY	Description
#1	2	Running Board(use for left or right)	#7	8	M8 Flat Washers
#2	2	Driver/Left Front Mounting Bracket (DFM/PFM)	#8	8	M8 Lock Washers
#3	2	Driver Center 1 st Mounting Bracket (DCM1/PCM1)	#9	16	M6 x 25mm Hex Bolts
#4	2	Driver Center 2 nd Mounting Bracket (DCM2/PCM2)	#10	16	M6 x 20mm T-Bolts
#5	2	Driver/Left Rear Mounting Bracket (DRM/PRM)	#11	48	M6 Flat Washers
#6	8	M8 x 35mm Hex Bolts	#12	32	M6 Nylon Lock Nuts



PROCEDURE

STEP 1

Locate (4) mounting points on the vehicle. Find the threaded insert located in between the first pair of holes along the pinch weld.



iRunning Board Installation Instruction

Application: For 2020 Jeep Gladiator

Rev:20191101

STEP 2

Attach the Mounting Bracket to the vehicle with:

- (1) M8-35mm Hex Bolt
- (1) M8 Lock Washer
- (1) M8 Flat Washer
- (2) M6 Nylon Lock Nuts
- (4) M6 Flat Washers
- (2) M6-25 Hex Bolts

(2) M6 Nylon Lock Nuts
(4) M6 Flat Washers
(2) M6-25 Hex Bolts

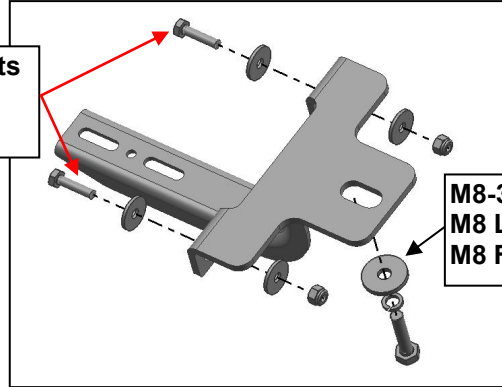

M8-35mm Hex Bolt
M8 Lock Washer
M8 Flat Washer

STEP 3 Repeat **STEP 2** to install all remaining Mounting Brackets.

STEP 4

Slip M6 x 20mm T-Bolts into the bottom channel

NOTE: (4) T-Bolts for each channel



STEP 5

Attach the Running Board to the Mounting Brackets with

- (2) M6-20 T-Bolts
- (2) M6 Flat washers
- (2) M6 Nylon Lock Nuts

Level and adjust Running Board properly and tighten all hardware.

NOTE: Torque all M6 nylon lock nuts to 7 lb-ft.

Same installation for other brackets

