

# iBoard®

## iBoard® by APS

PART#: IB-107

READ INSTRUCTIONS CAREFULLY BEFORE STARTING INSTALLATION. REMOVE CONTENTS FROM BOX AND VERIFY ALL PARTS ARE PRESENT. ASSISTANCE IS RECOMMENDED.

\*ROCKER PANEL MOUNT  
\*NO DRILLING REQUIRED

Fastener Size	Tightening Torque (ft-lbs)	Required
6mm	6-7	√
8mm	16-18	√
10mm	31-32	X
12mm	56-58	X
14mm	92-94	X

### PART LIST

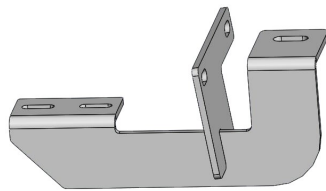

Driver Front Mounting Bracket (DFM)

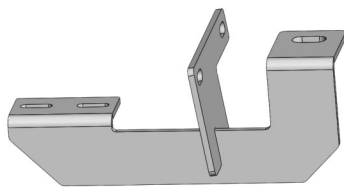

Driver Center Mounting Bracket (DCM)

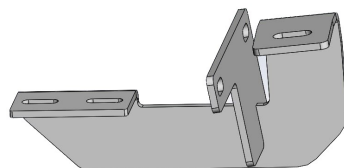

Driver Rear Mounting Bracket (DRM)

Front

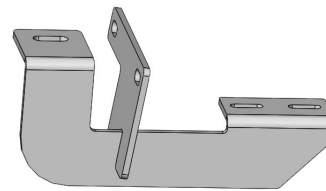

Passenger Front Mounting Bracket (PFM)

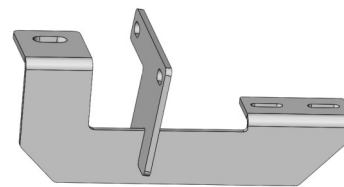

Passenger Center Mounting Bracket (PCM)

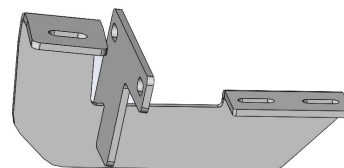

Passenger Rear Mounting Bracket (PRM)



Customer Support: [info@iboardauto.com](mailto:info@iboardauto.com)

# iBoard®

## Hardware Package A (For Bracket Installation)

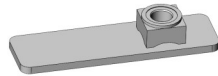

X6

M8X1.25 Nut Plate

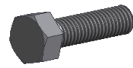

X12

M8X1.25-35mm Hex Bolt



X12

M8 Large Flat Washer



X12

M8 Lock Washer



X12

M6X1-25mm Inner Hex Bolt



X24

M6 Large Flat Washer



X12

M6X1 Nylon Lock Nut

## Hardware Package B (For Aluminum Step Bar Installation Only, Not Supply to Stainless Steel Step Bar)

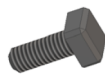

X12

M6X1-20mm Square Head Bolt



X12

M6 Large Flat Washer



X12

M6X1 Nylon Lock Nut

## Hardware Package C (For Stainless Steel Step Bar Installation Only, Not Supply to Aluminum Step Bar)

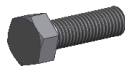

X12

M6X1-20mm Hex Bolt



X12

M6 Lock Washer



X12

M6 Flat Washer

## STEP 1

**THE FACTORY ROCK RAILS, SIDE STEPS OR RUNNING BOARDS MUST BE REMOVED BEFORE INSTALLING.**

Start installation from the passenger side front of the vehicle. Determine if the vehicle has an opening or a threaded hole in the floor panel on the mounting location, (Fig 1 - 2). Remove any insulation that may be covering the mounting locations.

Insert M8X1.25 Nut Plate Into Opening And Line Up the Welded Nut With the Mounting Hole

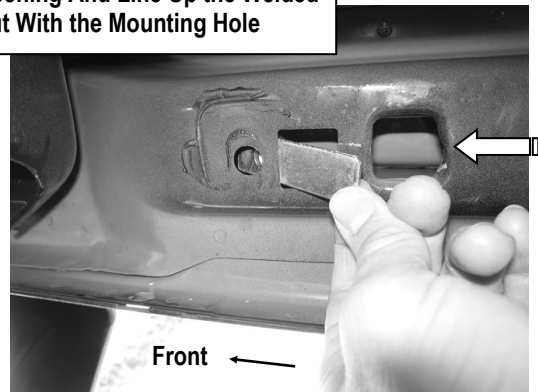

(Fig 1) Vehicle with opening In Floor Panel (Passenger Side-Front Mounting Location)

# iBoard®



(Fig 2) Vehicle with 8mm Threaded Hole In Floor Panel

## STEP 2

Select the Passenger Front Mounting Bracket (PFM). **VERY IMPORTANT:** The (6) Mounting Brackets are similar but not the same. Identify the brackets carefully by using the bracket pictures on "Part List" page and the labels attached on the brackets.

### Vehicles with opening in the floor panel:

Insert (1) M8X1.25 Nut Plate into the large square opening in the floor panel. Line up the threaded nut with the small round hole, (Fig 1). Bolt the Bracket to the M8X1.25 Nut Plate with (1) M8X1.25-35mm Hex Bolt, (1) M8 Lock Washer and (1) M8 Large Flat Washer, (Fig 3). Do not fully tighten hardware.

### Vehicles with factory threaded hole in floor panel:

Bolt the upper hole of the mounting bracket to the threaded hole in the floor panel with (1) M8X1.25-35mm Hex Bolt, (1) M8 Lock Washer and (1) M8 Large Flat Washer, (Fig 2 & 3). Do not fully tighten hardware.

## STEP 3

Line up the mounting plate on the Bracket with the (2) factory holes in the pinch weld. Bolt the Mounting Bracket to the back of the pinch weld using the included (2) M6X1-25mm Inner Hex Bolts, (4) M6 Large Flat Washers and (2) M6X1 Nylon Lock Nuts, (Fig 3). Leave loose at this time.

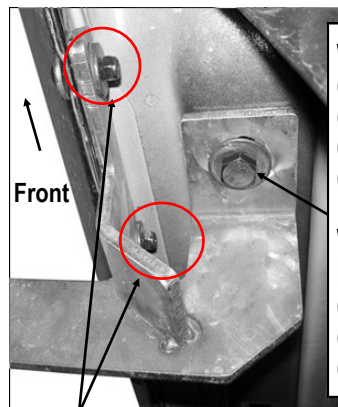

With Opening in Floor Panel:

- (1) M8X1.25 Nut Plate
- (1) M8X1.25-35mm Hex Bolt
- (1) M8 Lock Washer
- (1) M8 Large Flat Washer

With Factory Threaded Hole In Floor Panel:

- (1) M8X1.25-35mm Hex Bolt
- (1) M8 Lock Washer
- (1) M8 Large Flat Washer

- (2) M6X1-25mm Inner Hex Bolts
- (4) M6 Large Flat Washers
- (2) M6X1 Nylon Lock Nuts

(Fig 3) Passenger Front Mounting Bracket (PFM) Installation

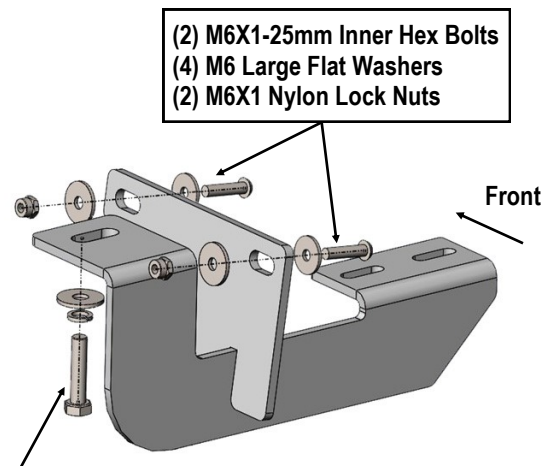

- (2) M6X1-25mm Inner Hex Bolts
- (4) M6 Large Flat Washers
- (2) M6X1 Nylon Lock Nuts

With Opening in Floor Panel:

- (1) M8X1.25 Nut Plate
- (1) M8X1.25-35mm Hex Bolt
- (1) M8 Lock Washer
- (1) M8 Large Flat Washer

With Factory Threaded Hole In Floor Panel:

- (1) M8X1.25-35mm Hex Bolt
- (1) M8 Lock Washer
- (1) M8 Large Flat Washer

(Fig 4) Passenger Front Mounting Bracket (PFM) Installation

# iBoard®

## STEP 4

Repeat **Steps 1—3** to install the **Passenger Center and Rear Mounting Brackets**. Do not fully tighten hardware at this time.

## STEP 5

Once all (3) mounting brackets are installed, then proceed to the Step Bar installation. According to the style of Step Bar proceed to the correct installation STEPS.

**Note:** Aluminum Step Bar refer to **STEP 6**; Stainless Steel Step Bar skip to **STEP 7**.

## STEP 6

### **Aluminum Step Bar Installation:**

Select a **Aluminum Step Bar**. Slip (3) M6x1-20mm Square Head Bolts into each bottom channel (**Fig 5**). Carefully position the Step Bar onto the (3) Mounting Brackets.

**IMPORTANT:** Do not slide the Step Bar on the Brackets or the bottom surface of the board will be damaged. Attach the Step Bar to each Mounting Brackets with (2) M6x1-20mm Square Head Bolts, (2) M6 Large Flat Washers and (2) M6X1 Nylon Lock Nuts, (**Fig 6**). Do not fully tighten at this time.

Level and adjust the Step Bar and fully tighten all hardware.

Repeat **Steps 1-6** for the other side Step Bar installation. **The installation is completed!!!**



(Fig 5) Slip M6X1-20 Square Head Bolts Into The Bottom Channels

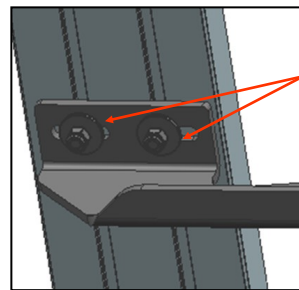

(2) M6X1-20mm Square Head Bolts  
(2) M6 Large Flat Washers  
(2) M6X1 Nylon Lock Nuts  
**IMPORTANT: TORQUE FOR 6MM FASTNERS MUST LESS THAN 6 -7 FT-LBS OR THE FASTNERS WILL BE DAMAGED!**

(Fig 6) Running Board Installed Onto Mounting Bracket

## STEP 7

### **Stainless Steel Step Bar Installation:**

Select a **Stainless Steel Step Bar** (with the U-Sliders installed on the Bar). Loose the U-Sliders, reposition the U-Sliders onto the board according to the (3) Installed Mounting Brackets location, (**Fig 7**). Re-secure the U-Sliders on the Step Bar. Attach the Step Bar to the installed Mounting Brackets with (6) M6X1-20mm Hex Bolts, (6) M6 Large Flat Washers & (6) M6 Lock Washers, (**Fig 8**). Do not fully tighten hardware at this time.

Level and adjust the Step Bar and fully tighten all hardware.

Repeat **Steps 1-5 and 7** for the other side Step Bar installation. **The installation is completed!!!**

# iBoard®



(Fig 7) Slide & line up the U-Slider with the installed mounting brackets along bottom channel

(2) M6X1-20mm Hex Bolts  
(2) M6 Large Flat Washers  
(2) M6 Lock Washers  
**IMPORTANT: TORQUE FOR 6MM FASTNERS MUST LESS THAN 6-7 FT-LBS OR THE FASTNERS WILL BE DAMAGED!**

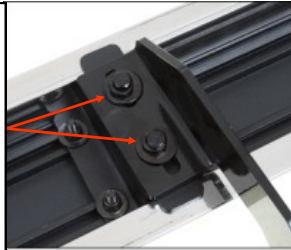

(Fig 8) Step Bar Installed on Bracket Installed (Example)

## Attention

Do periodic inspections to the installation to make sure that all hardware is secure and tight.

In order to protect your bars/boards, please use only mild soap/non-abrasive products for cleaning.