

iBoard®

iBoard® by APS

PART#: IB-084

READ INSTRUCTIONS CAREFULLY BEFORE STARTING INSTALLATION. REMOVE CONTENTS FROM BOX AND VERIFY ALL PARTS ARE PRESENT. ASSISTANCE IS RECOMMENDED.

*ROCKER PANEL MOUNT
*NO DRILLING REQUIRED

Fastener Size	Tightening Torque (ft-lbs)	Required
6mm	6-7	√
8mm	16-18	X
10mm	31-32	X
12mm	56-58	√
14mm	92-94	X

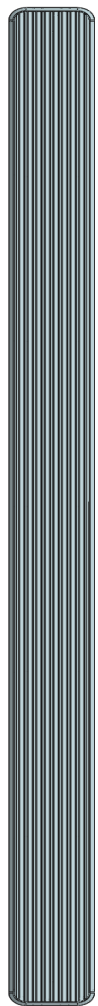

Driver Side Step Bar

Front
↑

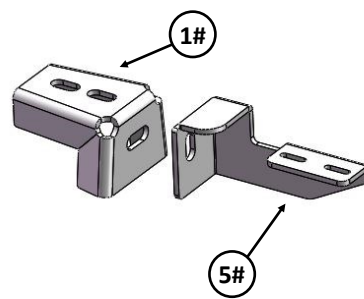
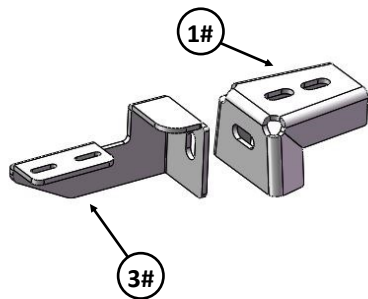
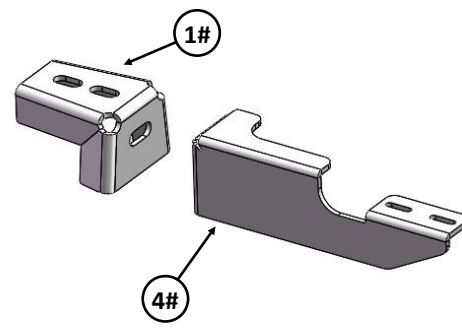
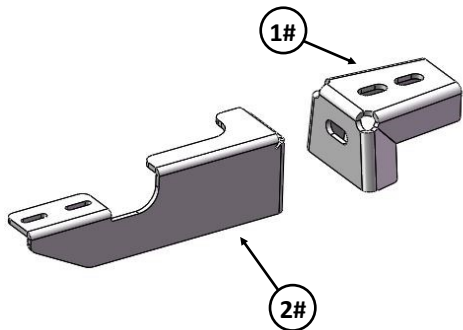



Passenger Side Step Bar

iBoard®

Mounting Bracket List					
Item	QTY	Description	Item	QTY	Description
1#	4	Mounting Brackets	4#	1	Passenger Front Bar Bracket
2#	1	Driver Front Bar Bracket	5#	1	Passenger Rear Bar Bracket
3#	1	Driver Rear Bar Bracket			

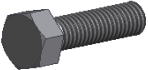
Hardware Package A (For Bracket Installation)					
Item	QTY	Description	Item	QTY	Description
1#	4	M12X1.75-35mm Hex Bolts	3#	4	M12 Lock Washers
2#	8	M12 Flat Washers	4#	4	M12X1.75 Hex Nuts

 1#

 2#

 3#

 4#

Hardware Package B (For Aluminum Step Bar Installation Only, Not Supply to SS. Step Bar)					
Item	QTY	Description	Item	QTY	Description
1#	8	M6X1-20mm Square Head Bolts	3#	8	M6X1 Nylon Lock Nuts
2#	8	M6 Large Flat Washers			

 1#

 2#

 3#

Hardware Package C (For Stainless Steel Step Bar Installation Only, Not Supply to Aluminum Step Bar)					
Item	QTY	Description	Item	QTY	Description
1#	8	M6X1-20mm Hex Bolts	3#	8	M6 Flat Washers
2#	8	M6 Lock Washers			

 1#

 2#

 3#

iBoard®

STEP 1

Start installation toward the front of the driver side of the vehicle. Remove the factory body mount bolt (**Fig 1**). Select (1) Mounting Bracket. Insert the factory body mount bolt through the appropriate slot, the rubber bushing and back into the vehicle. **NOTE:** Do not remove the rubber bushing. The Mounting Bracket will install over the rubber bushing. **IMPORTANT:** The Brackets are equipped with (2) mounting slots. Determine correct model year for proper installation (**Figs 2-3**):

- a. **1987 - 1995 Vehicles:** Use the inner slot. Do not fully tighten hardware at this time.
- b. **1997 - 2006 Vehicles:** Use the outer slot closer to the bend in the Bracket. Do not fully tighten hardware at this time.



(Fig 1) Remove Factory Body Mount Bolt

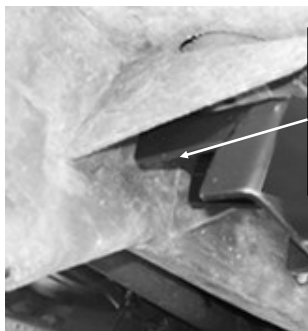

Re-Use The Factory Hex Bolt To Attach The Bracket To Rubber Bushing And Body Mount

(Fig 2) Mounting Bracket Installation Pictured

1987 - 1995 Vehicles:
Use The Inner Slot

1997 - 2006 Vehicles: Use
The Outer Slot Closer To
The Bend In The Bracket

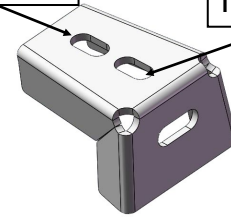

(Fig 3) Mounting Bracket

STEP 2

Select the Driver Front Bar Bracket, attach to the Mounting Bracket with (1) M12X1.75-35mm Hex Bolt, (2) M12 Flat Washers, (1) M12 Lock Washer and (1) M12 X1.75 Hex Nut (**Fig 4**). Repeat to install driver side rear bracket (**Fig 5**).

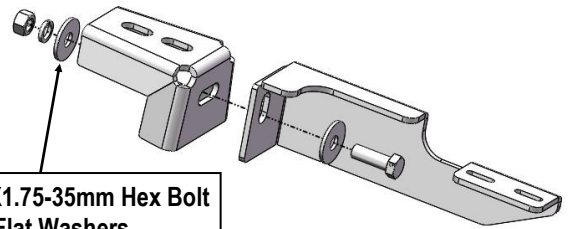

(1) M12X1.75-35mm Hex Bolt
(2) M12 Flat Washers
(1) M12 Lock Washer
(1) M12X1.75 Hex Nut

(Fig 4) Driver Front Bar Bracket Installation Pictured

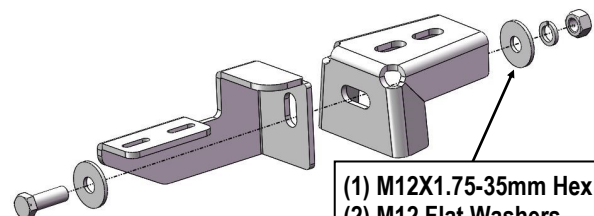

(1) M12X1.75-35mm Hex Bolt
(2) M12 Flat Washers
(1) M12 Lock Washer
(1) M12X1.75 Hex Nut

(Fig 5) Driver Rear Bar Bracket Installation Pictured

STEP 3

Repeat **Steps 1-2** to install the driver side rear brackets (**Fig 5**).

iBoard®

STEP 4

Once all (2) mounting brackets are installed, then proceed to the Step Bar installation. According to the style of Step Bar proceed to the correct installation STEPS.

Note: Aluminum Step Bar refer to 5; Stainless Steel Step Bar skip to STEP 6.

STEP 5

Aluminum Step Bar Installation:

Select a **Aluminum Step Bar**. Slip (2) M6x1-20mm Square Head Bolts into each bottom channel (**Fig 6**). Carefully position the Step Bar onto the (2) Mounting Brackets.

IMPORTANT: Do not slide the Step Bar on the Brackets or the bottom surface of the board will be damaged. Attach the Step Bar to each Mounting Brackets with (2) M6x1-20mm Square Head Bolts, (2) M6 Large Flat Washers and (2) M6X1 Nylon Lock Nuts, (**Fig 7**). Do not fully tighten at this time.

Level and adjust the Step Bar and fully tighten all hardware. Repeat **Steps 1-5** for the other side Step Bar installation. **The installation is completed!!!**



(Fig 6) Slip M6X1-20mm Square Head Bolts Into The Bottom Channels

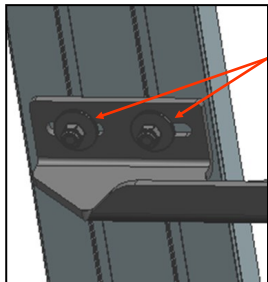

(2) M6X1-20mm Square Head Bolts
(2) M6 Large Flat Washers
(2) M6X1 Nylon Lock Nuts
IMPORTANT: TORQUE FOR 6MM FASTNERS MUST LESS THAN 6-7 FT-LBS OR THE FASTNERS WILL BE DAMAGED!

(Fig 7) Step Bar Installed Onto Mounting Bracket

STEP 6

Stainless Steel Step Bar Installation:

Select a **Stainless Steel Step Bar** (with the U-Sliders installed on the Bar). Loose the U-Sliders, reposition the U-Sliders onto the board according to the (2) Installed Mounting Brackets location, (**Fig 8**). Re-secure the U-Sliders on the Step Bar. Attach the Step Bar to the installed Mounting Brackets with (4) M6X1-20mm Hex Bolts, (4) M6 Large Flat Washers & (4) M6 Lock Washers, (**Fig 9**). Do not fully tighten hardware at this time.

Level and adjust the Step Bar and fully tighten all hardware. Repeat **Steps 1-4 and 6** for the other side Step Bar installation. **The installation is completed!!!**

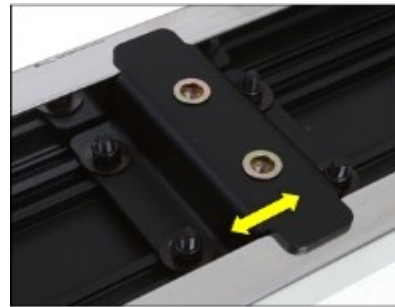

(Fig 8) Slide & line up the U-Slider with the installed mounting brackets along bottom channel

(2) M6X1-20mm Hex Bolts
(2) M6 Large Flat Washers
(2) M6 Lock Washers

IMPORTANT: TORQUE FOR 6MM FASTNERS MUST LESS THAN 6-7 FT-LBS OR THE FASTNERS WILL BE DAMAGED!

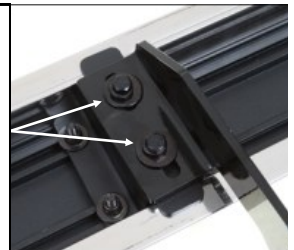

(Fig 9) Step Bar Installed on Bracket Installed (Example)

Attention

Do periodic inspections to the installation to make sure that all hardware is secure and tight.

In order to protect your bars/boards, please use only mild soap/non-abrasive products for cleaning.