

# iBoard®

## iBoard® by APS

PART#: IB-R941

READ INSTRUCTIONS CAREFULLY BEFORE STARTING INSTALLATION. REMOVE CONTENTS FROM BOX AND VERIFY ALL PARTS ARE PRESENT. ASSISTANCE IS RECOMMENDED.

\*ROCKER PANEL MOUNT  
\*DRILLING MAY BE REQUIRED

Fastener Size	Tightening Torque (ft-lbs)	Required
6mm	6-7	√
8mm	16-18	√
10mm	31-32	X
12mm	56-58	X
14mm	92-94	X

### PART LIST

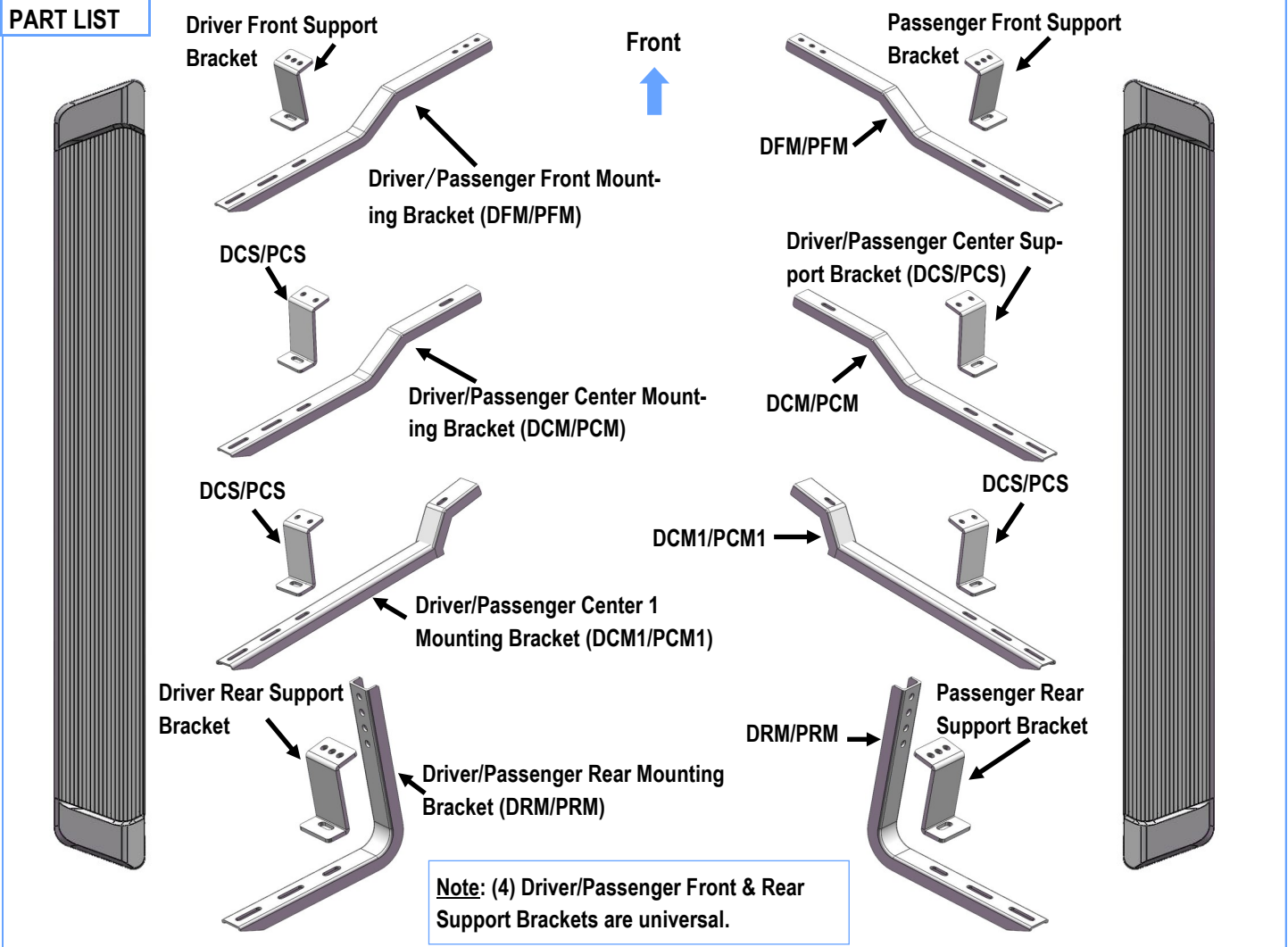

Customer Support: [info@iboardauto.com](mailto:info@iboardauto.com)

# iBoard®



## STEP 1

Start installation at the passenger side of the vehicle, (Fig 1). Mounting Brackets will bolt to the A,B,C,D mounting locations on pinch weld, (Fig 1).

**Note:** Drilling may be required on mounting location A & D on some trims.

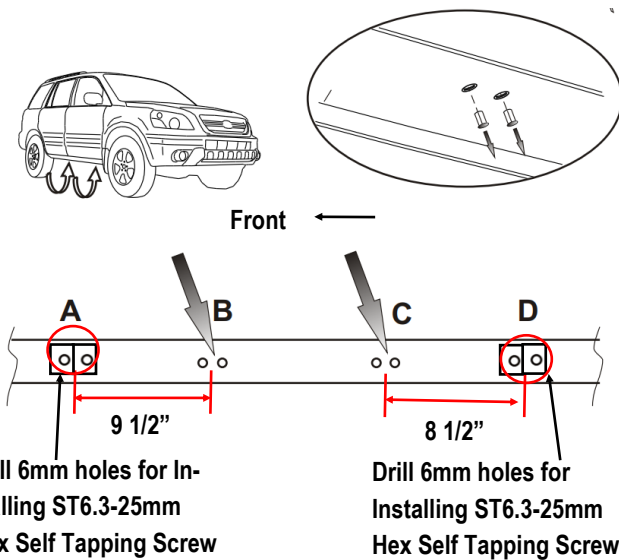

(Fig 1) Passenger Side Mounting Locations

## STEP 2

Assemble Passenger Front Mounting Bracket (DFM/PFM) with Passenger Front Support Bracket using (1) M8X1.25-20mm Hex Bolt, (2) M8 Flat Washers and (1) M8 X1.25 Nylon Lock Nut, as shown (Fig 2). Do not fully tighten at this time.

Passenger Front Support Bracket

DFM/PFM

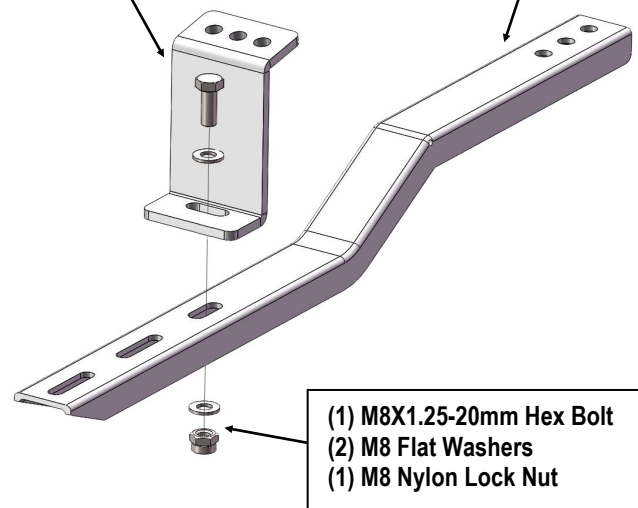

(Fig 2) Passenger Front Mounting Bracket Assembly

## STEP 3

Attach the assembled Passenger Front Brackets to Mounting Location A (see Fig 1) on vehicle with (4) ST6.3-25mm Hex Self Tapping Screws, (Fig 3). Do not fully tighten at this time.

**Note:** Drilling may be required on rocker panel and pinch weld for installing (4) ST6.3-25mm Hex Self Tapping Screws on some models or trims.

# iBoard®

## STEP 5

Repeat **Step 4** to install Passenger Center 1 Mounting Bracket (**DCM1/PCM1**) and Passenger Center Support Bracket (**DCS/PCS**) to location **C** (See **Fig 1 & 5**). Do not fully tighten at this time.

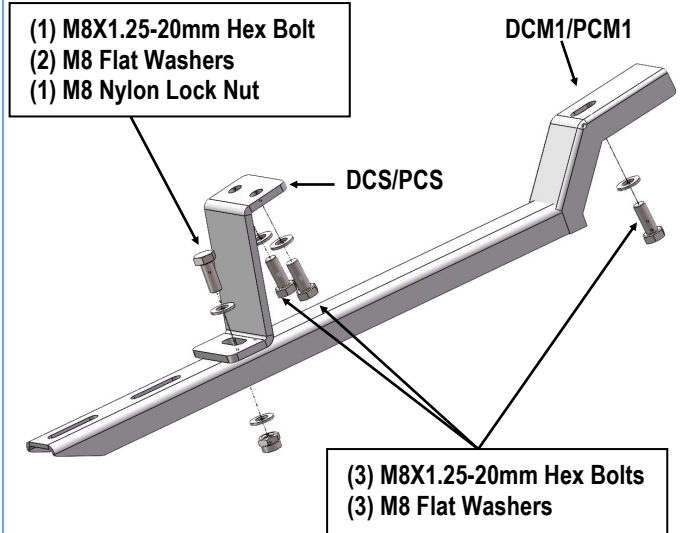

(Fig 5) Passenger Side Center 1 Brackets Installed

## STEP 6

Assemble Passenger Rear Support Bracket and Passenger Rear Mounting Bracket (**DRM/PRM**) using (1) M8X1.25-20mm Hex Bolt, (2) M8 Flat Washers and (1) M8 Nylon Lock Nut.

Attach the assembled Passenger Rear Brackets to mounting location **D** (See **Fig 1**) on vehicle with (5) ST6.3-25mm Hex Self Tapping Screws, (**Fig 6**). Do not fully tighten at this time.

**Note:** Drilling may be required on rocker panel and pinch weld for installing (5) ST6.3-25mm Hex Self Tapping Screws on some models or trims.

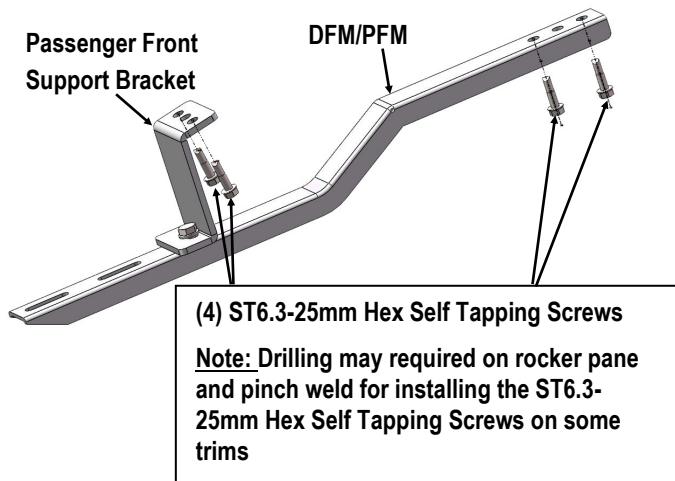

(Fig 3) Passenger Side Front Brackets Installed

## STEP 4

Assemble Passenger Center Mounting Bracket (**DCM/PCM**) and Passenger Center Support Bracket (**DCS/PCS**) using (1) M8X1.25-20mm Hex Bolt, (2) M8 Flat Washers and (1) M8X1.25 Nylon Lock Nut.

Attach the assembled Passenger Center Brackets to location **B** (See **Fig 1**) on vehicle with (3) M8X1.25-20mm Hex Bolts and (3) M8 Flat Washers (**Fig 4**). Do not fully tighten at this time.

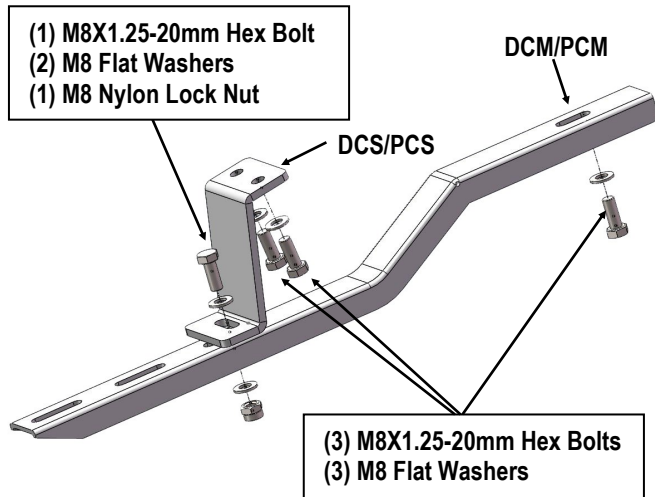

(Fig 4) Passenger Side Center Brackets Installed

# iBoard®

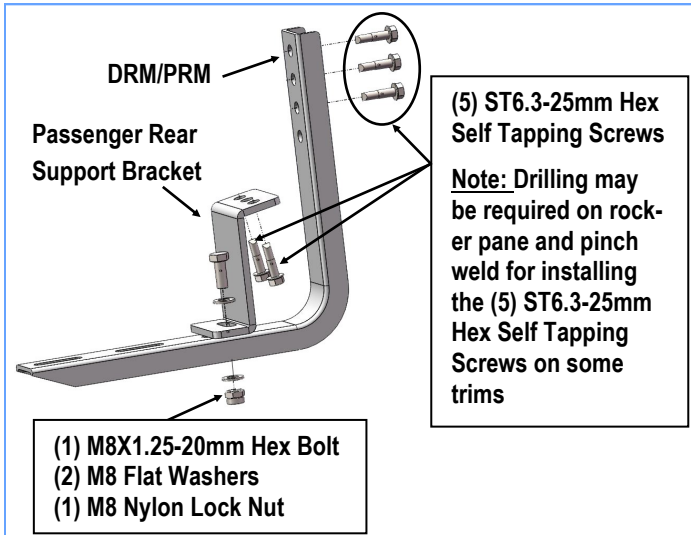

(Fig 6) Passenger Side Rear Brackets Installed

## STEP 7

Select a Running Board. Slip (4) M6x1-20mm Square Head Bolts into each bottom channel (Fig 7). Carefully position the Running Board onto the (4) Mounting Brackets.

**IMPORTANT:** Do not slide the Running Board on the Brackets or the bottom surface of the board will be damaged. Attach the Running Board to each Mounting Bracket with (2) M6x1-20mm Square Head Bolts, (2) M6 Large Flat Washers and (2) M6 Nylon Lock Nuts (Fig 8). Do not fully tighten at this time.

M6X1-20mm Square Head Bolts

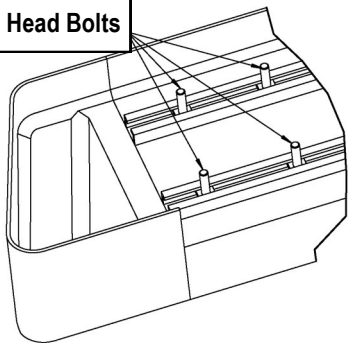

(Fig 7) Slip (4) M6X1-20mm Square Head Bolts Into Each Bottom Channel

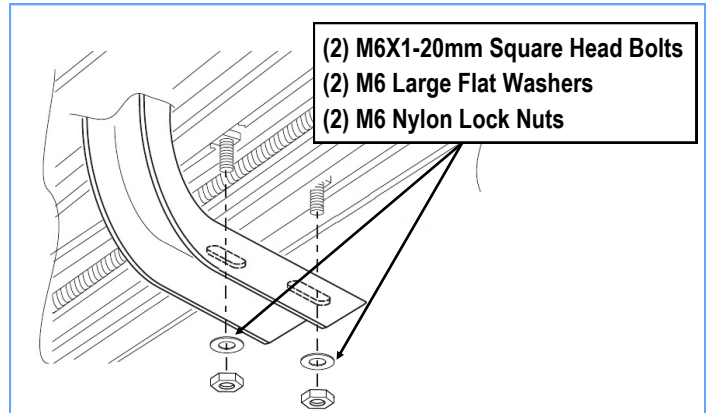

(Fig 8) Running Board Installed Onto Mounting Bracket

## STEP 8

Level and adjust the Running Board and fully tighten all hardware.

**Important:** Please follow the recommended Tightening Torques shown in the table on page 1. Don't over tighten, or the nuts/bolts will be damaged.

## STEP 9

Repeat **Steps 1-8** for the other side Running Board installation. The installation is completed.

### Attention

Do periodic inspections to the installation to make sure that all hardware is secure and tight.

In order to protect your bars/boards, please use only mild soap/non-abrasive products for cleaning.