

iBoard®

iBoard® by APS

PART#: IB-109A-B

READ INSTRUCTIONS CAREFULLY BEFORE STARTING INSTALLATION. REMOVE CONTENTS FROM BOX AND VERIFY ALL PARTS ARE PRESENT. ASSISTANCE IS RECOMMENDED.

*ROCKER PANEL MOUNT
*DRILLING IS REQUIRED

Fastener Size	Tightening Torque (ft-lbs)
6mm	6-7
8mm	16-18
10mm	31-32
12mm	56-58
14mm	92-94

PART LIST

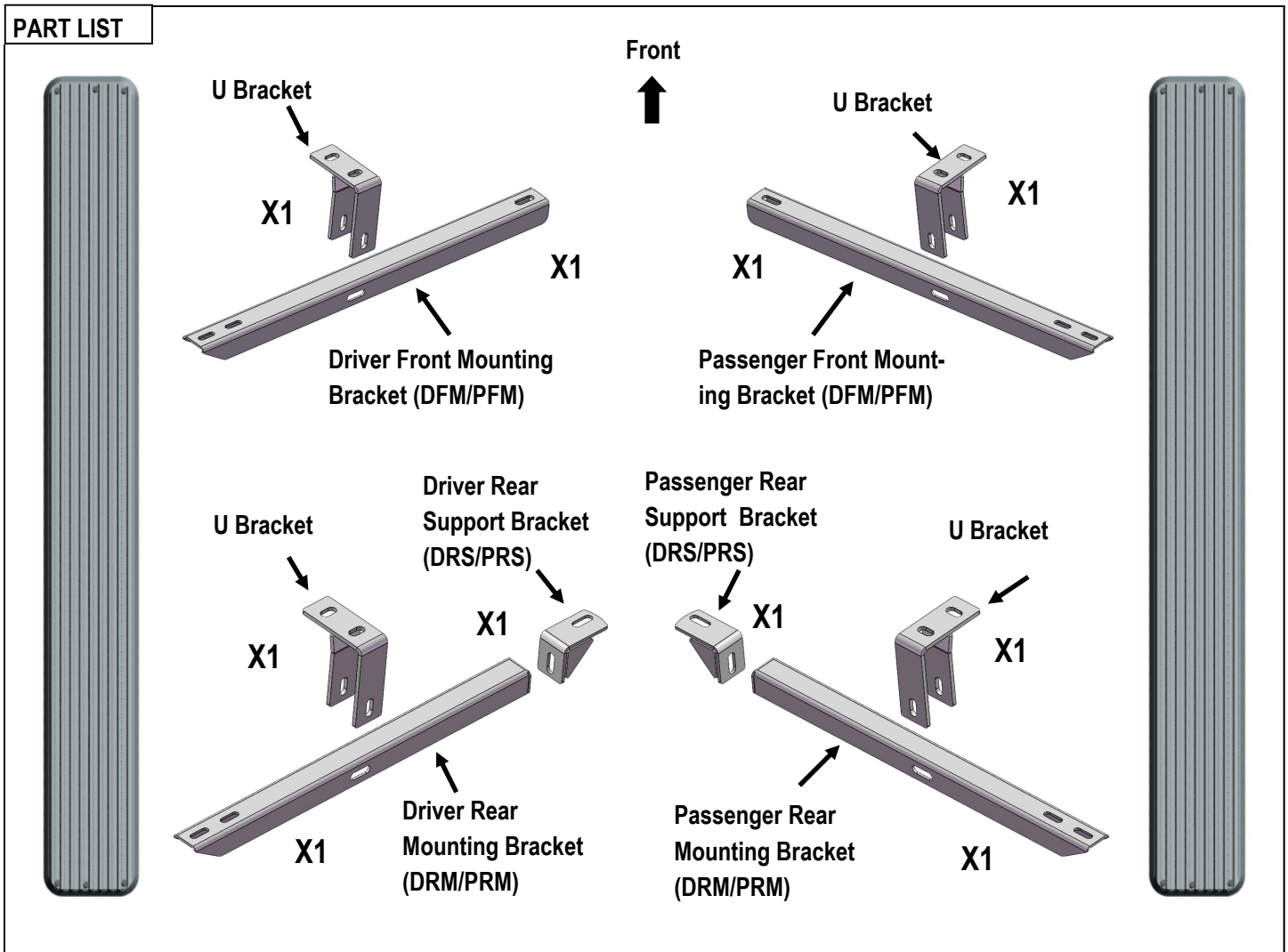

Customer Support: info@iboardauto.com

iBoard®



X4

M8X1.25-60mm Hex Bolt



X14

M8X1.25-25mm Hex Bolt



X8

M6X1-20mm
Square Head Bolt



X24

M8 Flat Washer



X18

M8 Lock Washer



X6

M8 Hex Nut



X8

M6 Large Flat Washer



X8

M6X1 Nylon Lock Nut

STEP 1

Identify and separate the driver and passenger side front and rear brackets. Start installation on the driver/left side of the vehicle.

Cut out the paper template on **Fig 15** labeled "Driver Side". Cut out the square section on the bottom of the Template and the (2) 8mm holes on the top. Fold the top of the Template up along the dotted line, (**Fig 2**). Hold the Template in place over the outer (2) factory 8mm threaded holes next to the pinch weld, (**Figs 3 & 4**). **IMPORTANT:** There are (4) threaded holes at each mounting location, (2) inner on bottom of frame channel and (2) outer next to pinch weld, (**Fig 5**). Hold the correct Template over the outer threaded holes and up against the plastic cover, (**Fig 4**). Use a marker to trace the cut out section on the bottom of the Template onto the plastic cover. Repeat this Step to mark the rear bracket location for cutting.

Cut Out Square And (2) Round Holes

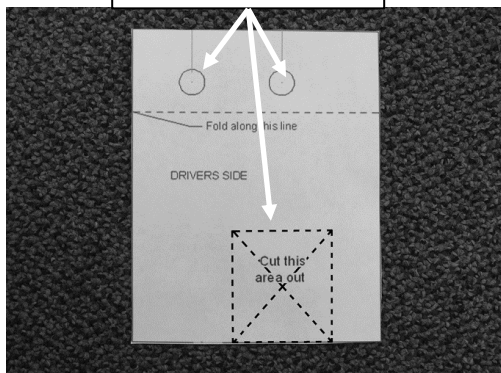

(Fig 1) Driver Side Template Pictured

Fold Up Along Dashed Line

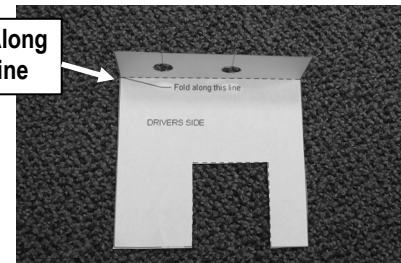

(Fig 2) Driver Side Template Pictured



(Fig 3) Driver Side Front Mounting Location Pictured

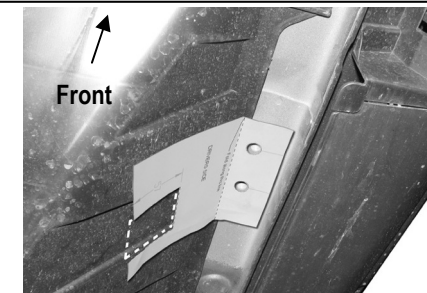

(Fig 4) Driver Front Side Location Pictured

With The Plastic Cover In Place, Hold The Driver Side Paper Template Over The (2) Threaded Holes Next To The Pinch Weld. Use A Marker To Trace The Square Cut Out Section On The Template. Remove Cover. Use A Utility Knife Or Hacksaw To Carefully Cut Out This Section. Check The Clearance Between The Bracket And The Cover Often For Proper Fit.

iBoard®

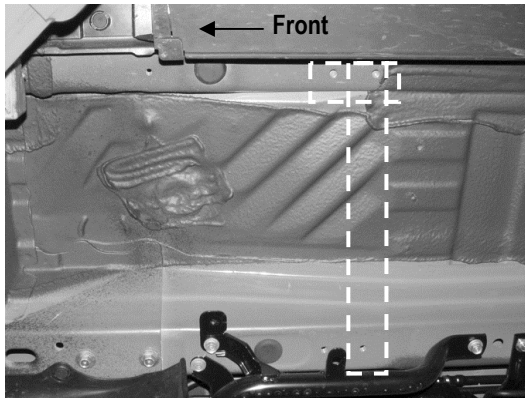

(Fig 5) Dashed Line Represents Driver Side Front Mounting Location For Bracket Assembly

STEP 2

Remove the plastic cover. Cut out the (2) sections as marked. **VERY IMPORTANT:** The Templates are driver and passenger side specific and have been provided for reference use only. It is the installer's responsibility to be absolutely sure that the correct location has been marked before cutting the plastic cover. To verify the locations before cutting, temporarily assemble the Mounting Brackets as pictured on **Page 1 "Part List"** and check the locations on the cover.

STEP 3

Partially install the plastic cover. **IMPORTANT:** Attach the cover to the vehicle with the outer (next to pinch weld) hardware only. Allow the cover to hang in place from the outer hardware. Do not install inner hardware at this time.

STEP 4

Locate the forward (2) 8mm threaded holes in the floor panel, (See **Step 1, Fig 5**). Select (1) U Bracket. Bolt the Bracket to the threaded holes with (2) M8X1.25-25mm Hex Bolts, (2) M8 Lock Washers, and (2) M8 Flat Washers, (**Fig 6**). Snug but do not fully tighten hardware at this time.

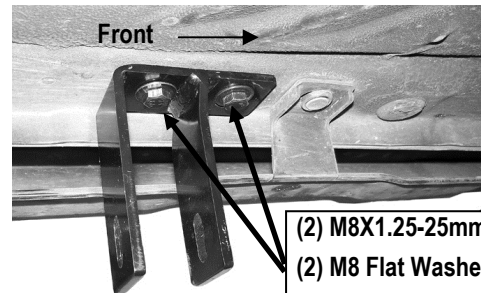

(Fig 6) Drive Front U Bracket Located

STEP 5

Select (1) Driver Front Mounting Bracket (**DFM/PFM**). Insert the Driver Front Mounting Bracket through the tabs on the U Bracket and into the hole cut out of the plastic cover. Line up the inner end of the Bracket with the rear threaded hole on the bottom of the frame channel in line with the outer holes, (**Fig 7**). Attach the Mounting Bracket to the frame channel with (1) M8X1.25-mm Hex Bolt, (1) M8 Lock Washer, and (1) M8 Flat Washer. Bolt the Driver Front Mounting Bracket to the (2) tabs on U Bracket with (1) M8X1.25-60mm Hex Bolt, (2) M8 Flat Washers, (1) M8 Lock Washers and (1) M8 Hex Nuts, (**Fig 8**). Do not tighten hardware at this time.

NOTE: The mounting tab on U Bracket will go toward front of vehicle.

iBoard®

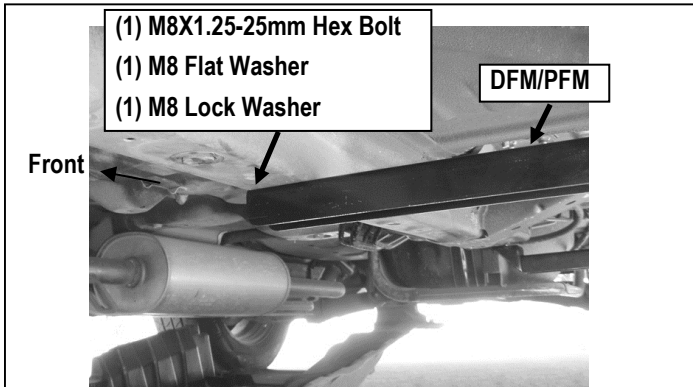

(Fig 7) Driver Front Mounting Bracket Installed

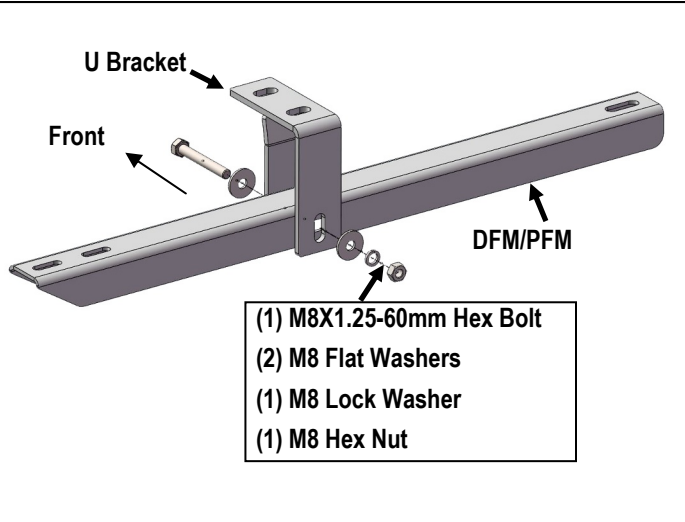

(Fig 8) Driver Front Mounting Bracket Installed

STEP 6

Next, select (1) Driver Rear Mounting Bracket (**DRM/PRM**), (1) U Bracket and (1) Driver Rear Support Bracket (**DRS/PRS**). Bolt the Support Bracket to the end of the Mounting Bracket with (1) M8X1.25-25mm Hex Bolt, (2) M8 Flat Washers, (1) M8 Lock Washer and (1) M8 Hex Nut, (**Fig 9**). Do not fully tighten hardware at this time.

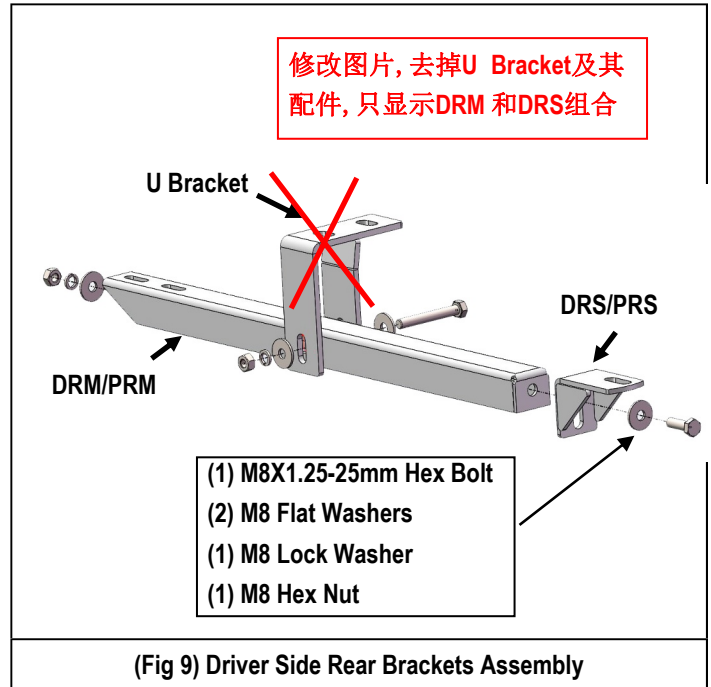

(Fig 9) Driver Side Rear Brackets Assembly

STEP 7

Repeat **Step 4** to install the U Bracket onto the vehicle (**Fig 11**). And repeat **Step 5** to install the Assembled Driver Rear Mounting Bracket onto the frame channel and U Bracket (**Fig 10 & 11**). Do not fully tighten hardware at this time.

NOTE: The mounting tab on U Bracket will go toward front of vehicle.

iBoard®

- (1) M8X1.25-25mm Hex Bolt
- (1) M8 Flat Washer
- (1) M8 Lock Washer

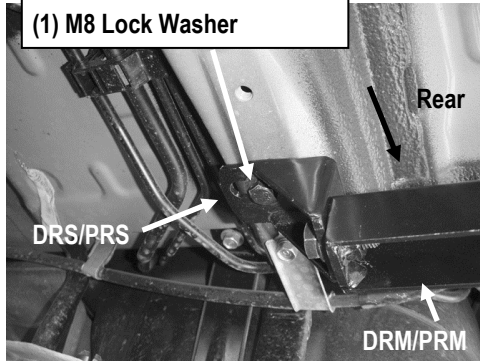

(Fig 10) Driver Rear Support Bracket Installed

修改图片, 把U Bracket与 DRM连接的螺栓等小配件炸开显示.

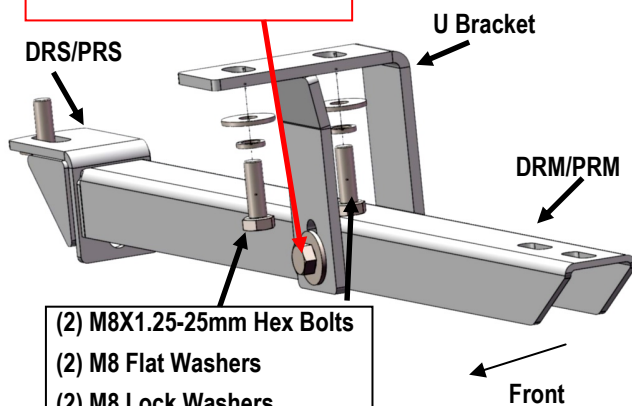

- (2) M8X1.25-25mm Hex Bolts
- (2) M8 Flat Washers
- (2) M8 Lock Washers

(Fig 11) Driver Rear U Bracket Installed

STEP 8

Select a Running Board. Slip (2) M6x1-20mm Square Head Bolts into each bottom channel (Fig 12). Carefully position the Running Board onto the (2) Mounting Brackets.

IMPORTANT: Do not slide the Running Board on the Brackets or the bottom surface of the board will be damaged. Attach the Running Board to each Mounting Brackets with (2) M6x1-20mm Square Head Bolts, (2) M6 Large Flat Washers and (2) M6 X1 Nylon Lock Nuts (Fig 13). Do not fully tighten at this time.



(Fig 12) Slip (2) M6X1-20mm Square Head Bolts Into Each Bottom Channel

- (2) M6X1-20mm Square Head Bolts
- (2) M6 Flat Washers
- (2) M6X1 Nylon Lock Nuts

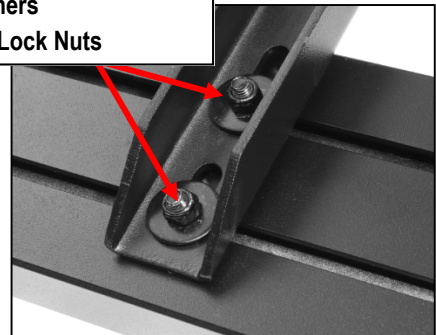

(Fig 13) Running Board Installed Onto Mounting Bracket

STEP 9

Level and adjust the Running Board and fully tighten all hardware.

STEP 10

Repeat **Steps 1-9** for the other side Running Board installation. The installation is completed (Fig 14).

iBoard®



(Fig 14) Installation Completed

Attention

Do periodic inspections to the installation to make sure that all hardware is secure and tight.

In order to protect your bars/boards, please use only mild soap/non-abrasive products for cleaning.

调整前面的排版, 把这些说明调整到上一页.

Fig 15 请按1:1打印在一张白纸上, 作为说明书的最后一页. 安装时, 客户需把图形剪下来, 所以剪下来的图形需与图上标注尺寸相符.

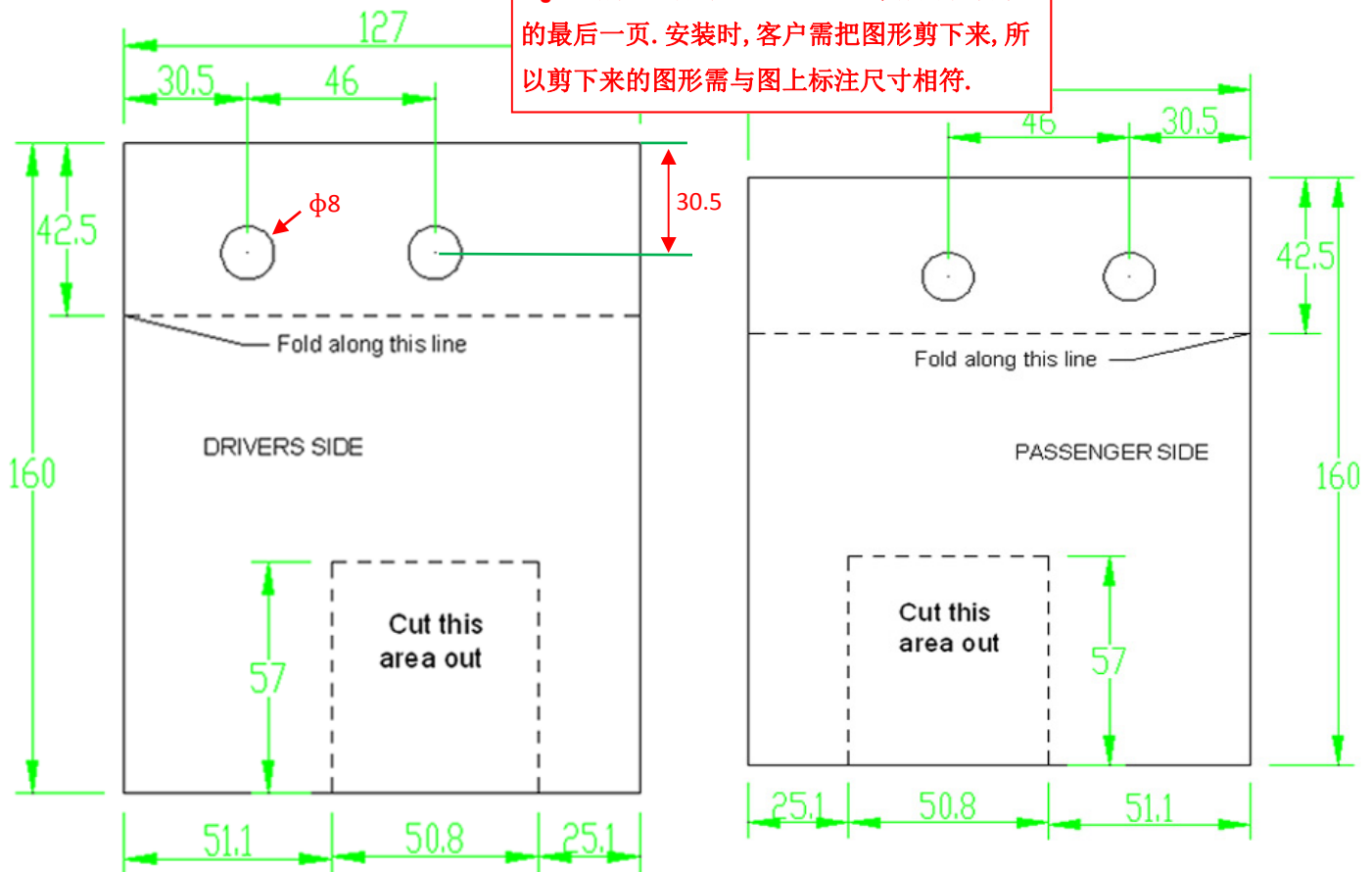

(Fig 15) Cut out paper templates