

# Installation Instructions for IB06SJJ3S

by APS Auto Parts Specialist Inc.

Application: FOR 1999-2016 Ford F-250/F-350/F-450/F-550 Super Duty Super Cab 5.5"ft Bed  
Estimated Time: 1 to 2 hours



Disclaimer: Instructions intended for persons aged 18+ please do not attempt without adult supervision. Instructions are not intended to replace professional installation. Damage from improper installation, misuse or modification to the product voids the manufacturer's warranty.

**PARTS LIST:**

Item	QTY	Description	Item	QTY	Description
#1	2	Running Board(use for left or right)	#6	12	M10 Lock Washers
#2	6	Mounting Brackets	#7	6	M10 Hex Nuts
#3	6	M10 Clip Nuts	#8	12	M6 T-Bolts
#4	12	M10 x 30mm Hex Bolts	#9	12	M6 Flat Washers
#5	18	M10 Flat Washers	#10	12	M6 Nylon Lock Nuts



**IMPORTANT ALERT: FOR WHEEL TO WHEEL APPLICATION, WEIGHT TO THE REAR END AREA OF THE RUNNING BOARD BEHIDE THE LAST BRACKET NEED TO LESS THEN 130KG.OVERWEIGHT IN THIS AREA MAYBE DAMAGE YOUR RUNNING BOARD.**

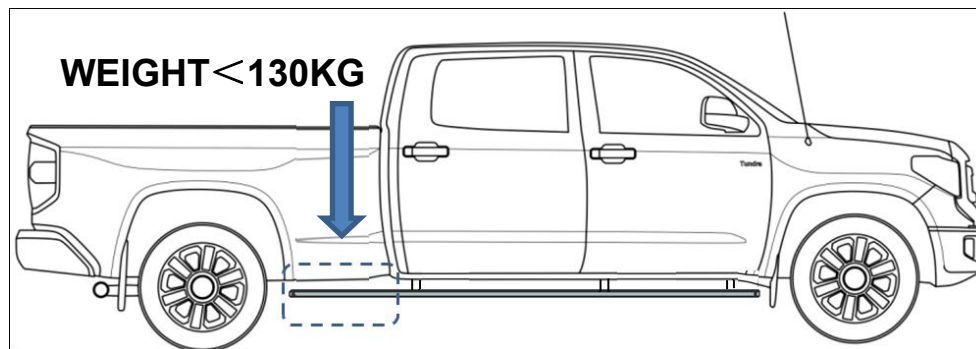

**PROCEDURE:**

- 1. REMOVE CONTENTS FROM BOX. VERIFY ALL PARTS ARE PRESENT. READ INSTRUCTIONS CAREFULLY BEFORE STARTING INSTALLATION. ASSISTANCE IS RECOMMENDED.**
2. Starting on the driver side-front of the vehicle,For super cab,locate the (4) pairs of factory holes along the bottom of the body, (pinch weld). Move to the 2nd and 3rd pair of holes, **(Figures 1 & 2)**. Each mounting location on the inner body panel is comprised of a rectangular hole with a round hole on each side directly above each pair of holes in the pinch weld.
3. Select (1) M10 Clip Nuts. Insert Clip Nuts one at a time into the rectangular opening and slide the threaded hole outward towards the round hole. Line up the threaded hole in the Clip with the round hole next to the rectangular opening. **NOTE:** Threaded nut must go towards the inside of the side panel, **(Figures 3)**.

4. Partially attach (1) Mounting Bracket to the Clip Nuts with the included (1)M10 x 30mm Hex Bolts, (1) M10 Lock Washers and (1) M10 Flat Washers. **NOTE:** Cradles on the Mounting Brackets should face the front of the vehicle.
5. Bolt the (1) bottom holes in the Mounting Bracket to the (1) holes in the pinch weld with the included (1)M10 x 30mm Hex Bolts, (2) M10 Flat Washers, (1) M10 Lock Washers and (1) M10 Hex Nuts. **NOTE:** Insert the Hex Bolt with Flat Washer through the pinch weld first then through the Bracket from the outside to inside. Do not tighten hardware at this time.
6. Move along the vehicle to the center and rear driver side, mounting location. Repeat **Steps 2—5** to install (2) Mounting Bracket in the center and rear location. **NOTE:** There are (2) mounting locations along the inner body panel. You need mark and drill 2 holes for installation,(**Figure 1B**).
7. Select a Running Board. Slip(6) M6 T-bolts into each bottom channel(**Fig 4**). Carefully position the Running Board onto the (3) Mounting Brackets. **IMPORTANT:** Do not slide, (front to back), the Running Board on the Brackets or damage to the finish may result. Attach the Running Board to the Mounting Brackets with(2) M6 T-bolts,(2)M6 flat washers and (2)M6 nylon lock nuts (**Fig 5**). Do not tighten at this time.
8. Level and adjust Running Board properly and tighten all hardware.
9. Repeat **Steps 2—8** for passenger/right Running Board installation.
10. Do periodic inspections to the installation to make sure that all hardware is secure and tight.

**To protect your investment**, wax this product after installing. Regular waxing is recommended to add a protective layer over the finish. Do not use any type of polish or wax that may contain abrasives that could damage the finish.

**For Polished Finishes:** Aluminum polish may be used to polish small scratches and scuffs on the finish. Mild soap may be used also to clean the Running Board.

**For Black Finishes:** Mild soap may be used to clean the Running Board.

#### Driver Side Installation Pictured

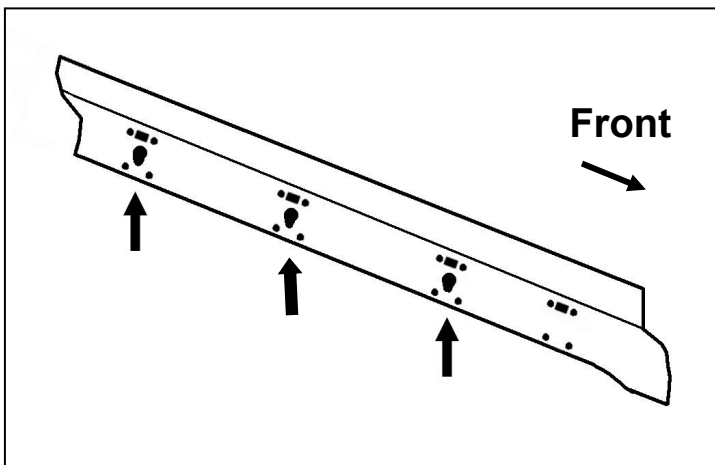

(Fig 1A) Driver/left body mounting locations illustrated back of rocker panel(for super cab)

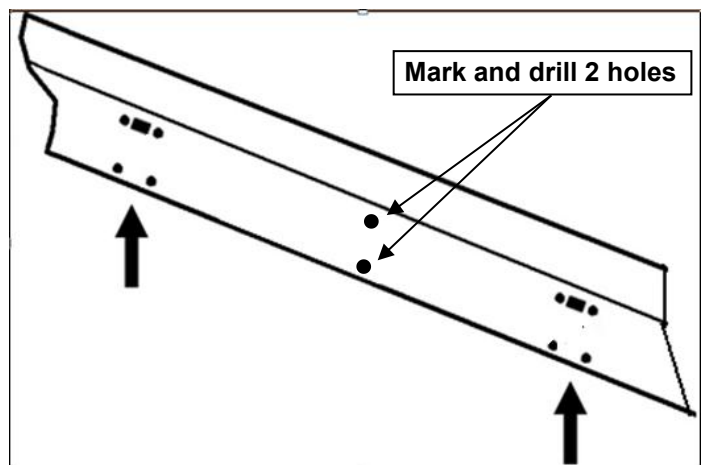

(Fig 1B) Driver/left body mounting locations illustrated back of rocker panel(for regular cab)

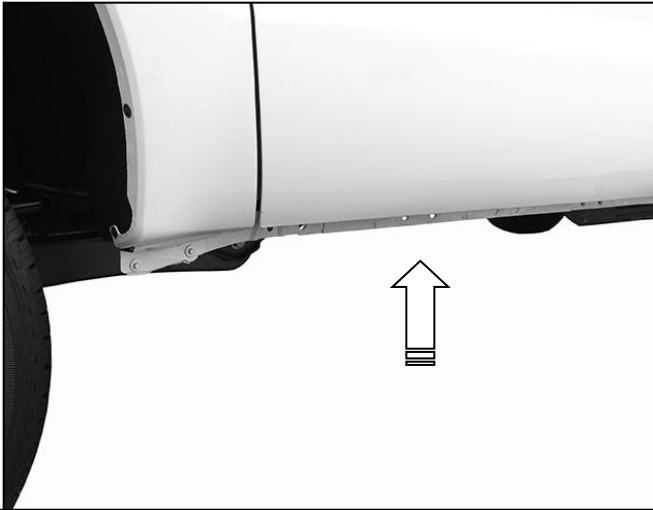

**(Fig 2) Bolt the front Bracket to the 2nd and 3rd pair of factory holes in the bottom of the pinch weld.**

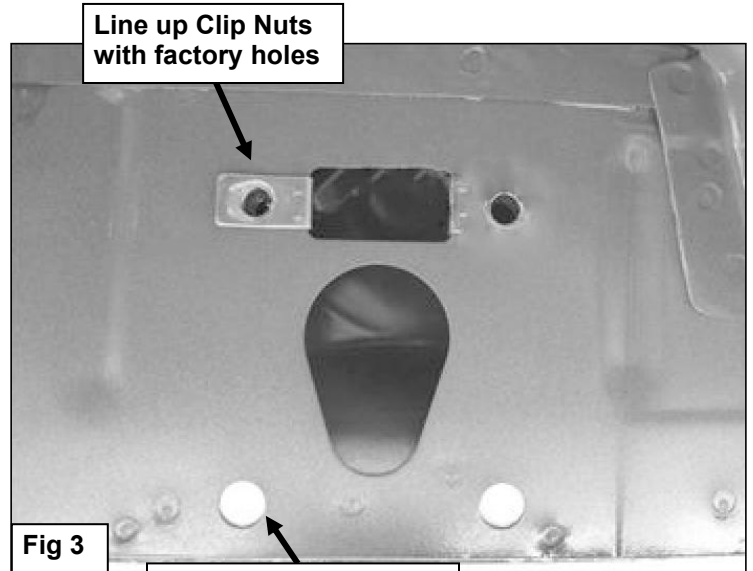

**Factory holes in pinch weld pictured from behind body panel**



**(Fig 4) Slip M6 T-bolts into the bottom channel**

- (2)M6 T-bolts**
- (2)M6 Flat Washers**
- (2)M6 Nylon Lock nuts**

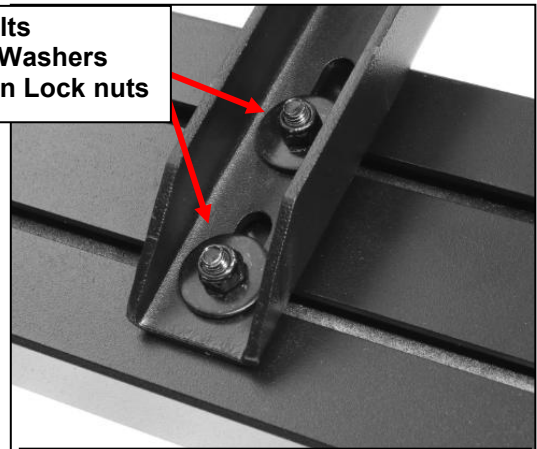

**(Fig 5) Drive side Bracket Installation**