

iBoard®

iBoard® by APS

PART#: IB-R042

READ INSTRUCTIONS CAREFULLY BEFORE STARTING INSTALLATION. REMOVE CONTENTS FROM BOX AND VERIFY ALL PARTS ARE PRESENT. ASSISTANCE IS RECOMMENDED.

*ROCKER PANEL MOUNT
*NO DRILLING REQUIRED

Fastener Size	Tightening Torque (ft-lbs)	Required
6mm	6-7	√
8mm	16-18	√
10mm	31-32	√
12mm	56-58	X
14mm	92-94	X

Item	QTY	Description	Item	QTY	Description
1#	4	Mounting Brackets	7#	8	M10 Flat Washers
2#	4	M8X1.25-25mm Hex Bolts	8#	4	M10 Lock Washers
3#	4	M8 Flat Washers	9#	4	M10 Hex Nuts
4#	4	M8 Lock Washers	10#	8	M6X1-20mm Square Head Bolts
5#	4	M8 Clip Nuts	11#	8	M6 Large Flat Washers
6#	4	M10X1.5-25mm Hex Bolts	12#	8	M6 Nylon Lock Nuts

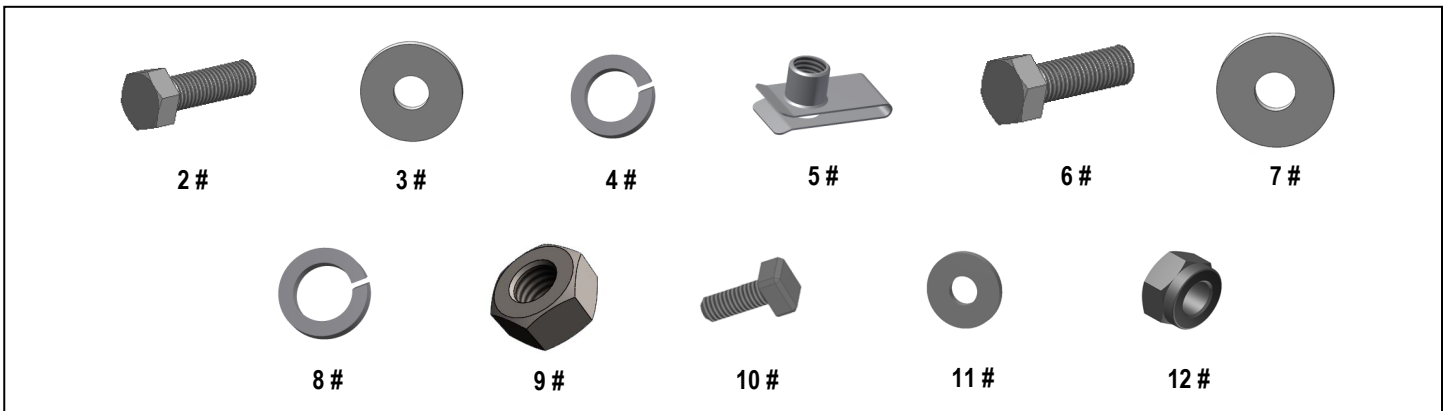

iBoard®

Driver

Front

Passenger

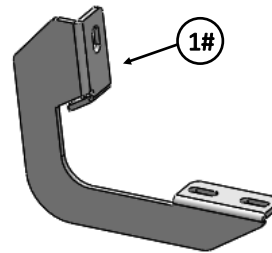
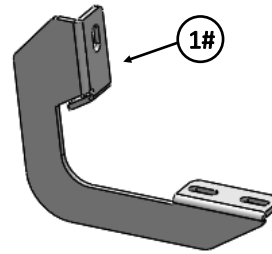
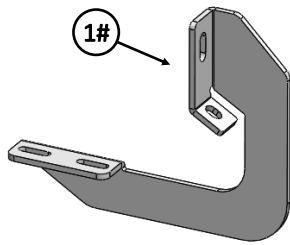
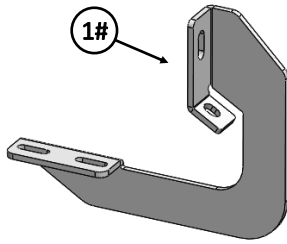

iBoard®

STEP 1

Start installation from the passenger side of the vehicle. Locate Passenger Side mounting locations as shown on **Fig 1**.

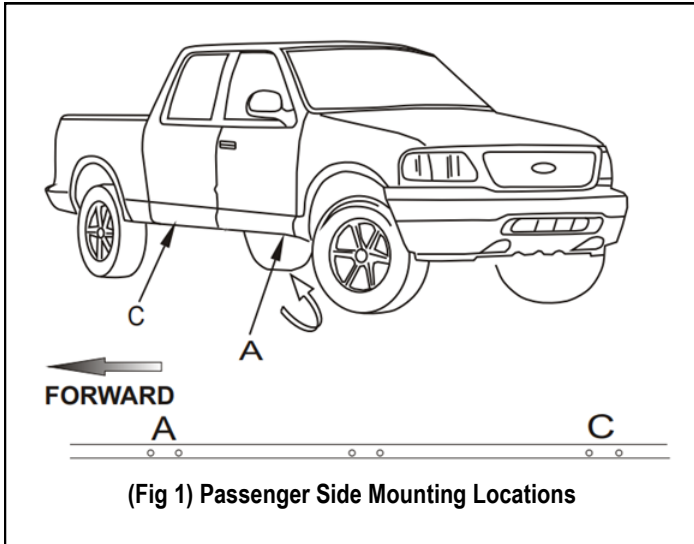

STEP 2

Start from the passenger front mounting location. Select (1) M8 Clip Nut. Install M8 Clip Nut as shown, (**Fig 2**).

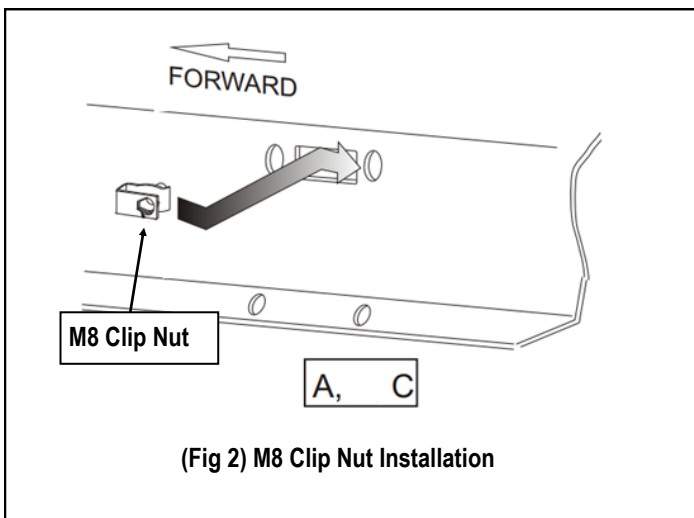

STEP 3

Attach (1) Mounting Bracket to the installed M8 Clip Nut and pinch weld with (1) M8X1.25-25mm Hex Bolt, (1) M8 Flat Washer, (1) M8 Lock Washer and (1) M10X1.5-25mm Hex Bolt, (2) M10 Flat Washers, (1) M10 Lock Washer, (1) M10 Hex Nut, (**Fig 3**). Do not fully tighten hardware at this time.

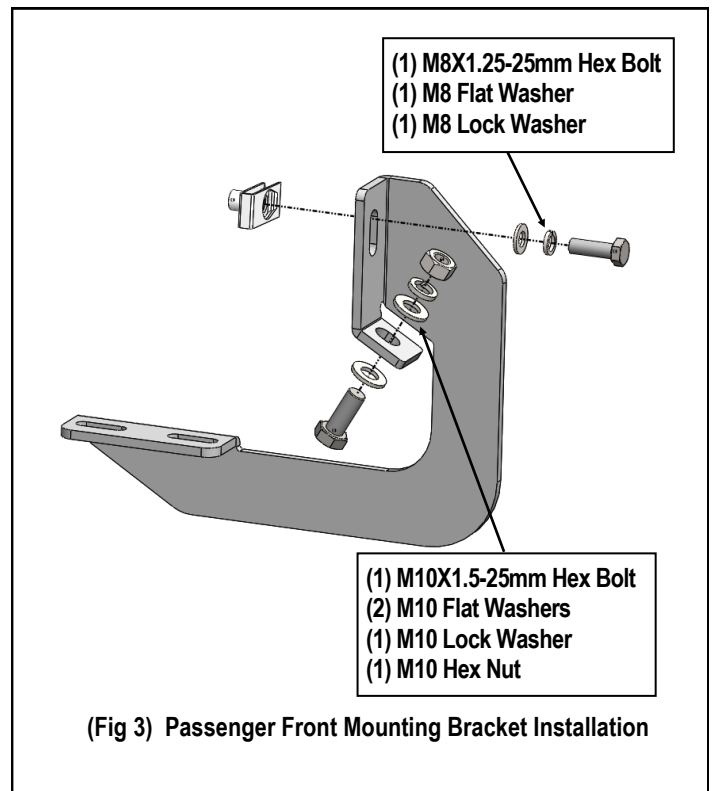

STEP 4

Move to the passenger side rear of the vehicle. Select (1) Mounting Bracket. Repeat **Steps 1—3** to install the passenger side Rear Mounting Brackets.

NOTE: All (4) Mounting Brackets will fit left or right side.

iBoard®

STEP 5

Select a Running Board. Slip (2) M6x1-20mm Square Head Bolts into each bottom channel (**Fig 4**). Carefully position the Running Board onto the (2) Mounting Brackets.

IMPORTANT: Do not slide the Running Board on the Brackets or the bottom surface of the board will be damaged. Attach the Running Board to each Mounting Bracket with (2) M6x1-20mm Square Head Bolts, (2) M6 Large Flat Washers and (2) M6 Nylon Lock Nuts (**Fig 5**). Do not fully tighten at this time.

M6X1-20mm Square Head Bolts

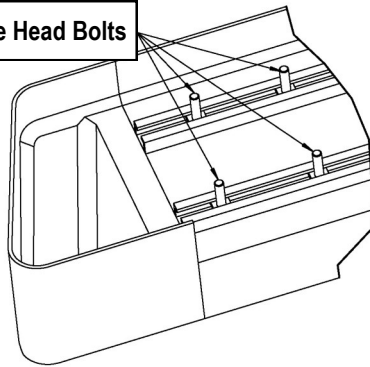

(Fig 4) Slip M6X1-20mm Square Head Bolts Into The Bottom Channels

(2) M6X1-20mm Square Head Bolts
(2) M6 Large Flat Washers
(2) M6 Nylon Lock Nuts

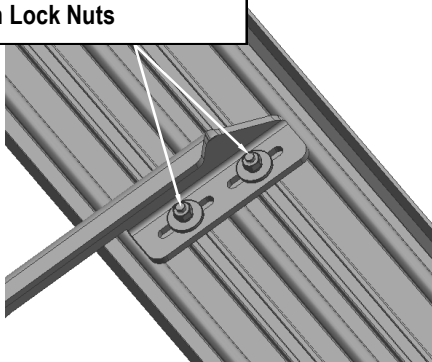

(Fig 5) Running Board Installed Onto Mounting Bracket

STEP 6

Level and adjust the Running Board and fully tighten all hardware.

Important: Please follow the recommended Tightening Torques shown in the table on page 1. Don't over tighten, or the nuts/bolts will be damaged.

STEP 7

Repeat **Steps 1-6** for the other side Running Board installation. The installation is completed .

Attention

Do periodic inspections to the installation to make sure that all hardware is secure and tight.

In order to protect your bars/boards, please use only mild soap/non-abrasive products for cleaning.