

iBoard®

iBoard® by APS

PART#: IB-R039

READ INSTRUCTIONS CAREFULLY BEFORE STARTING INSTALLATION. REMOVE CONTENTS FROM BOX AND VERIFY ALL PARTS ARE PRESENT. ASSISTANCE IS RECOMMENDED.

***ROCKER PANEL MOUNT
*DRILLING IS REQUIRED**

Fastener Size	Tightening Torque (ft-lbs)	Required
6mm	6-7	√
8mm	16-18	√
10mm	31-32	X
12mm	56-58	X
14mm	92-94	X

Item	QTY	Description	Item	QTY	Description
1#	6	Mounting Brackets	7#	8	M8 Hex Nuts
2#	2	Rear Mounting Brackets	8#	16	ST6.3-25mm Hex Self Tapping Screws
3#	6	Backing Plates	9#	16	M6X1-20mm Square Head Bolts
4#	8	M8X1.25-20mm Hex Bolts	10#	16	M6 Large Flat Washers
5#	16	M8 Flat Washers	11#	16	M6 Nylon Lock Nuts
6#	8	M8 Lock Washers			

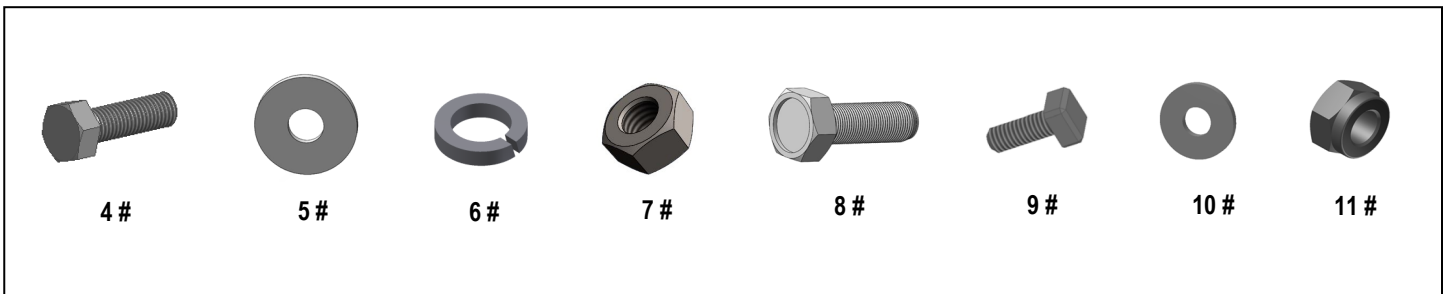

iBoard®

Driver

Front

Passenger

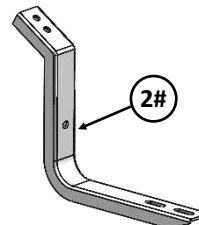
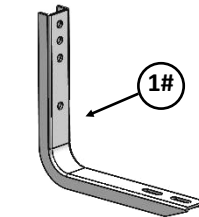
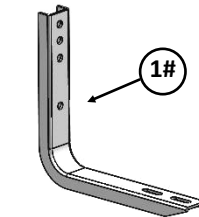
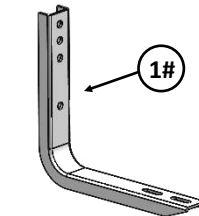
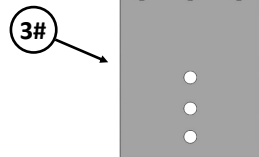
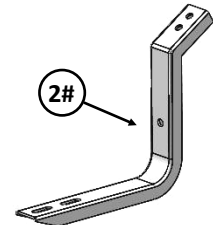
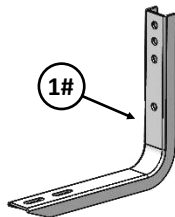
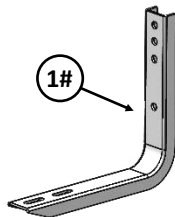
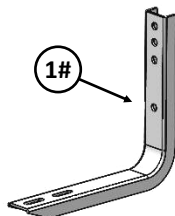

iBoard®

STEP 1

Start installing from the passenger side of the vehicle, drill 5/16" holes on pinch weld and body panel as shown (Both sides), (Fig 1).

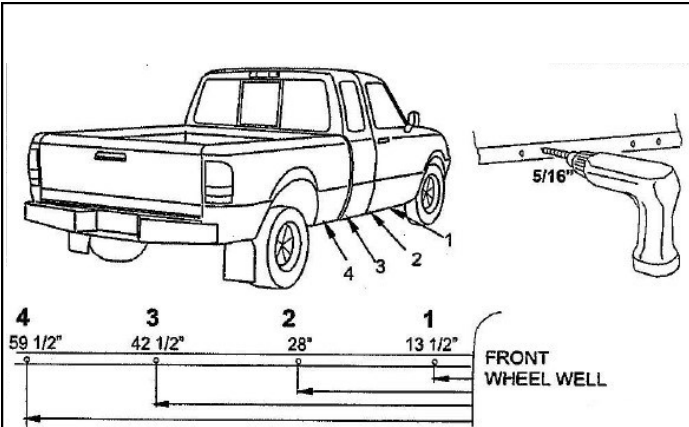

(Fig 1) Passenger Side Mounting Locations

STEP 2

Attach Passenger Front Mounting Bracket and Backing Plate to the body panel and pinch weld with (2) ST6.3x22mm Hex Self Tapping Screws, (1) M8X1.25-20mm Hex Bolt, (2) M8 Flat Washers, (1) M8 Lock Washer and (1) M8 Hex Nut, (Fig 2). Do not fully tighten at this time.

STEP 3

Move to passenger side 2nd & 3rd Mounting location. Repeat Step 2 to install (2) Mounting Brackets. Do not fully tighten at this time.

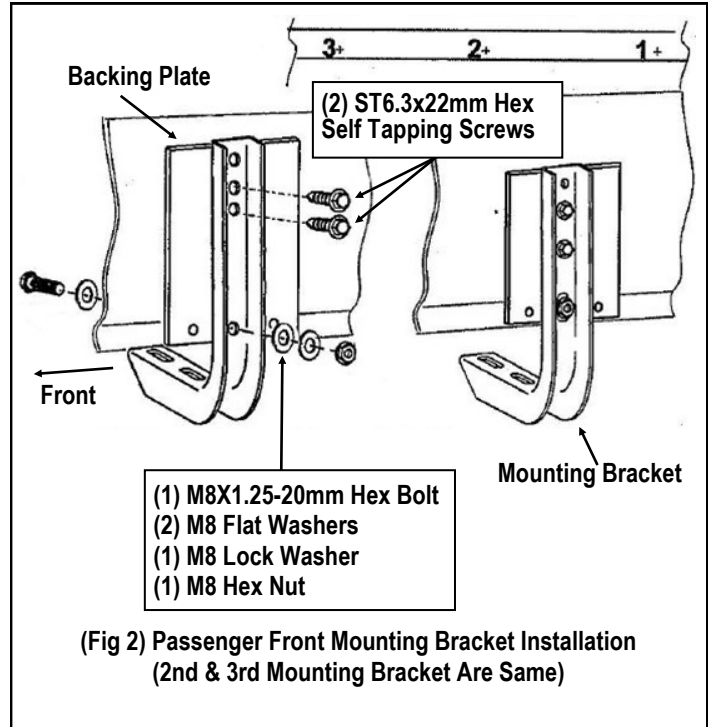

STEP 4

Move to passenger side rear Mounting location. Attach Passenger Rear Mounting Bracket to vehicle with (2) ST6.3x22mm Hex Self Tapping Screws, (1) M8X1.25-20mm Hex Bolt, (2) M8 Flat Washers, (1) M8 Lock Washer and (1) M8 Hex Nut, (Fig 3). Don't fully tighten hardware at this time.

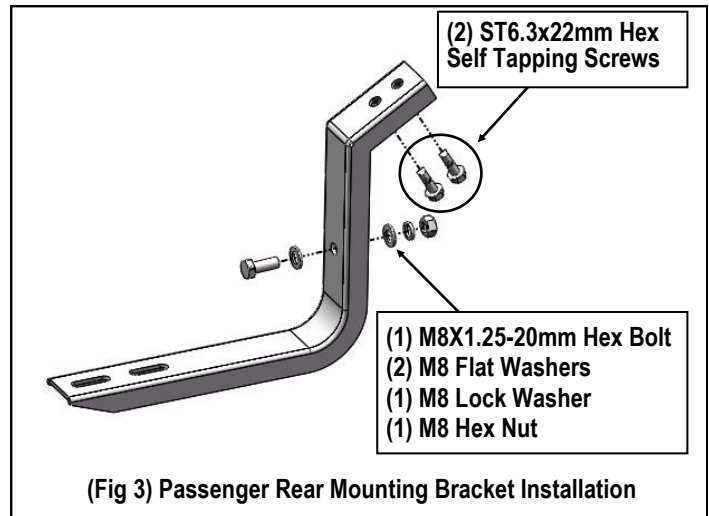

iBoard®

STEP 5

Select a Running Board. Slip (4) M6x1-20mm Square Head Bolts into each bottom channel (**Fig 4**). Carefully position the Running Board onto the (4) Mounting Brackets.

IMPORTANT: Do not slide the Running Board on the Brackets or the bottom surface of the board will be damaged. Attach the Running Board to each Mounting Bracket with (2) M6x1-20mm Square Head Bolts, (2) M6 Large Flat Washers and (2) M6 Nylon Lock Nuts (**Fig 5**). Do not fully tighten at this time.

M6X1-20mm Square Head Bolts

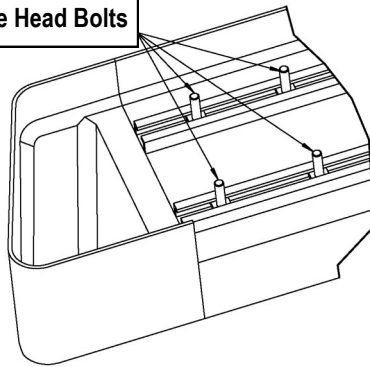

(Fig 4) Slip M6X1-20mm Square Head Bolts Into The Bottom Channels

(2) M6X1-20mm Square Head Bolts
(2) M6 Large Flat Washers
(2) M6 Nylon Lock Nuts

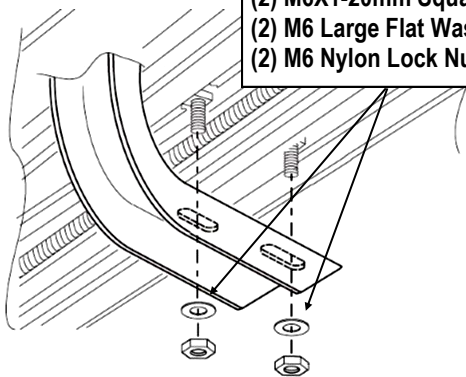

(Fig 5) Running Board Installed Onto Mounting Bracket

STEP 6

Level and adjust the Running Board and fully tighten all hardware.

Important: Please follow the recommended Tightening Torques shown in the table on page 1. Don't over tighten, or the nuts/bolts will be damaged.

STEP 7

Repeat **Steps 1-6** for the other side Running Board installation. The installation is completed .

Attention

Do periodic inspections to the installation to make sure that all hardware is secure and tight.

In order to protect your bars/boards, please use only mild soap/non-abrasive products for cleaning.