

iBoard®

iBoard® by APS

PART#: IB-R404

READ INSTRUCTIONS CAREFULLY BEFORE STARTING INSTALLATION. REMOVE CONTENTS FROM BOX AND VERIFY ALL PARTS ARE PRESENT. ASSISTANCE IS RECOMMENDED.

*ROCKER PANEL MOUNT
*DRILLING IS REQUIRED

Fastener Size	Tightening Torque (ft-lbs)	Required
6mm	6-7	√
8mm	16-18	√
10mm	31-32	√
12mm	56-58	X
14mm	92-94	X

PART LIST



Driver Side

Driver Front Mounting Bracket (DFM)

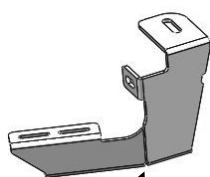
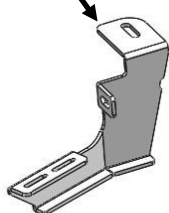

Driver Rear Mounting Bracket (DRM)

Front



Passenger Front Mounting Bracket (PFM)

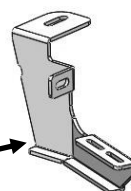

Passenger Center Mounting Bracket (PCM)

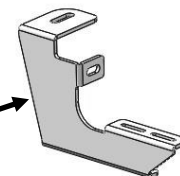

Passenger Center Mounting Bracket 1 (PCM1)

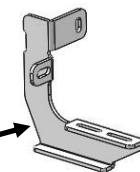

Passenger Rear Mounting Bracket (PRM)

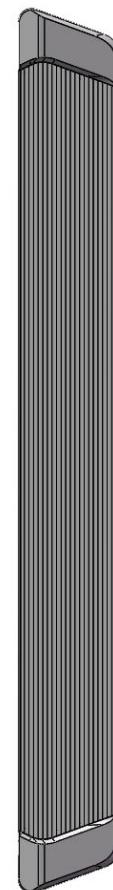
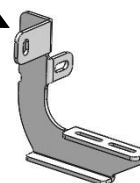
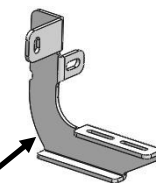

Passenger Side

Customer Support: info@iboardauto.com

iBoard®

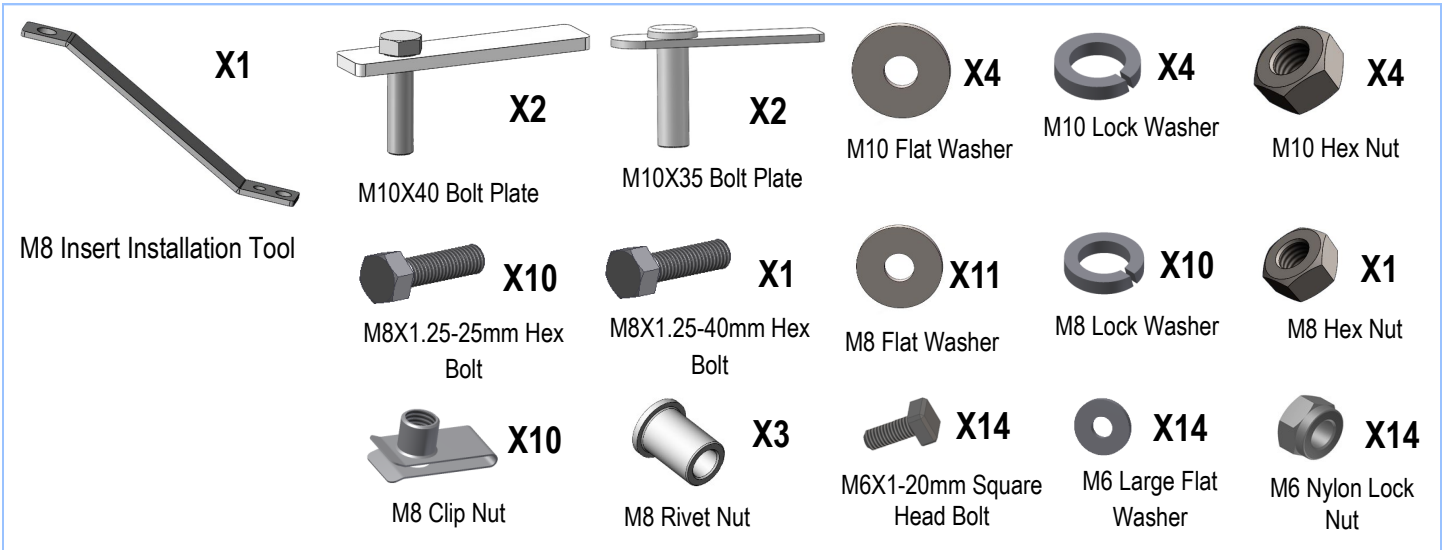

STEP 1

Starting installation from the driver side front of the vehicle. Locate and remove the rubber plug near the front tire opening, **(Fig 1)**. Select (1) M10X35 Bolt Plate, **(Fig 2)**. Insert the Bolt Plate into and across the opening, **(Fig 3)**.

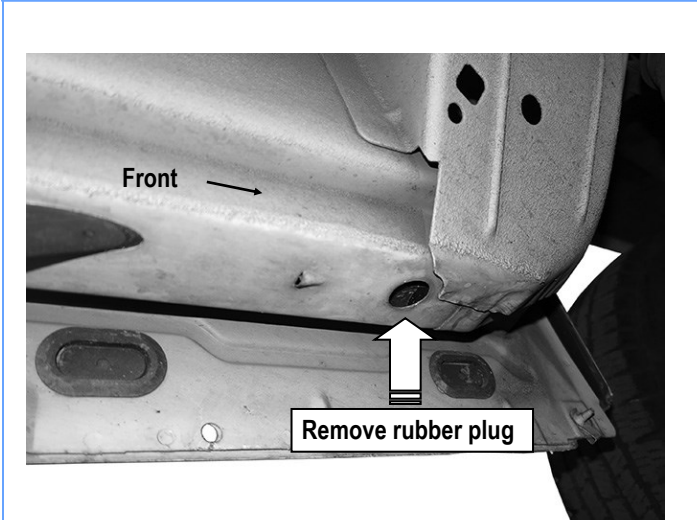

(Fig 1) Driver Side Front Mounting Location

STEP 2

Select the Driver Front Mounting Bracket (**DFM**). Attach the Bracket to the installed M10X35 Bolt Plate with (1) M10 Flat Washer, (1) M10 Lock Washer and (1) M10 Hex Nut, **(Fig 4)**. Do not fully tighten hardware at this time.

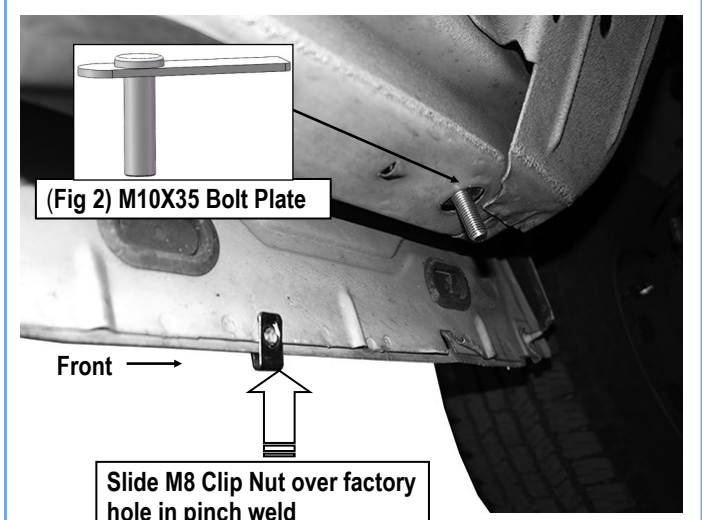

Fig 3

iBoard®

STEP 3

Line up the mounting tab on the Bracket with the factory hole in the pinch weld. Slide (1) M8 Clip Nut over the hole in the pinch weld with the nut toward the outside of the vehicle, (Fig 3).

Note: On some models, 5/16" holes may require to drill on the pinch weld to attach the Mounting Bracket.

- Line up the tab on the Bracket with a flat area on the back of the pinch weld.
- Fully tighten the M10 Hex Nut on the M10X35 Bolt Plate. Use the tab on the Bracket for a guide and drill a 5/16" hole through the tab and the pinch weld. ***IMPORTANT!*** Any cutting or drilling tool may break or shatter. Government regulations require safety glasses & equipment at all times when cutting or drilling.
- Slide (1) M8 Clip Nut over the drilled hole in the pinch weld with the nut toward the outside.

STEP 4

Attach the lower mounting hole on the Bracket to the M8 Clip Nut with (1) M8X1.25-25mm Hex Bolt, (1) M8 Lock Washer and (1) M8 Flat Washer, (Fig 4). Do not fully tighten the hardware.

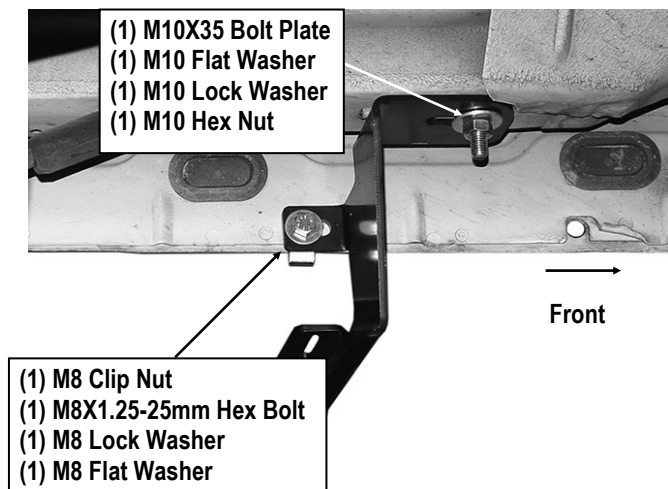

(Fig 4) Driver Front Mounting Bracket Installation

STEP 5

Move to the driver side rear of the vehicle, (Fig 6). Locate and remove the large oval rubber plug. Insert (1) M10X40 Bolt Plate into the opening, (Figs 5 & 6).

Attach the Driver Rear Mounting Bracket (DRM) to the M10X40 Bolt Plate with (1) M10 Flat Washer, (1) M10 Lock Washer and (1) M10 Hex Nut, (Fig 7). Repeat Steps 3 & 4 to attach the Mounting Bracket to the back of the pinch weld (Fig 7).

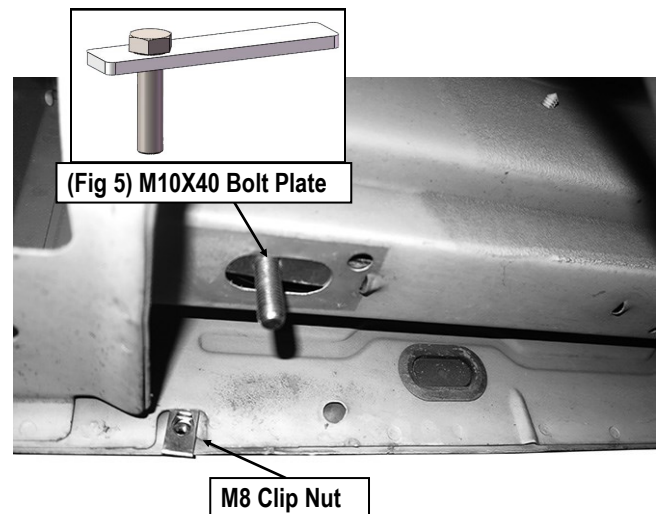

(Fig 6) Driver Side Rear Mounting Location

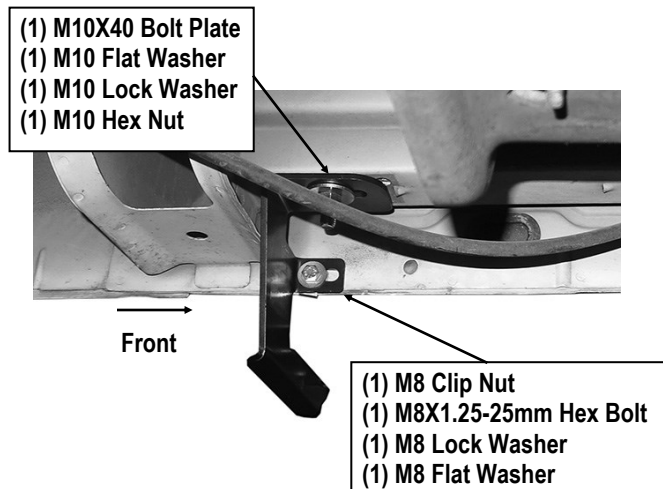

(Fig 7) Driver Rear Mounting Bracket Installation

iBoard®

STEP 6

Select the Driver Side Running Board (the short one). Slip (2) M6x1-20mm Square Head Bolts into each bottom channel (**Fig 8**). Carefully position the Running Board onto the (2) Mounting Brackets.

IMPORTANT: Do not slide the Running Board on the Brackets or the bottom surface of the board will be damaged. Attach the Running Board to each Mounting Bracket with (2) M6x1-20mm Square Head Bolts, (2) M6 Large Flat Washers and (2) M6 Nylon Lock Nuts, (**Fig 9**). Do not fully tighten hardware at this time.

Level and adjust the Running Board and fully tighten all hardware.

M6X1-20mm Square Head Bolts

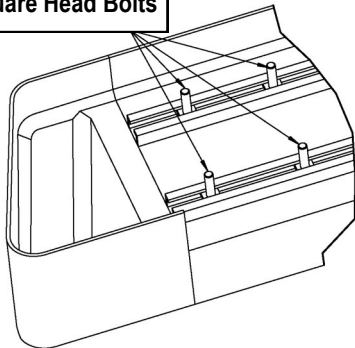

(Fig 8) Slip M6X1-20mm Square Head Bolts Into The Bottom Channels

(2) M6X1-20mm Square Head Bolts
(2) M6 Large Flat Washers
(2) M6 Nylon Lock Nuts

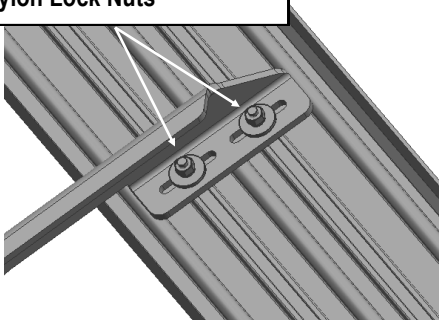

(Fig 9) Running Board Installed Onto Mounting Bracket (Example)

STEP 7

Move to the passenger side of the vehicle.

Start installation from the passenger side front of the vehicle, (**Fig 10**). Repeat **Steps 1—4** to install the Passenger Front Mounting Bracket (PFM), (**Fig 11**). Do not fully tighten hardware at this time.

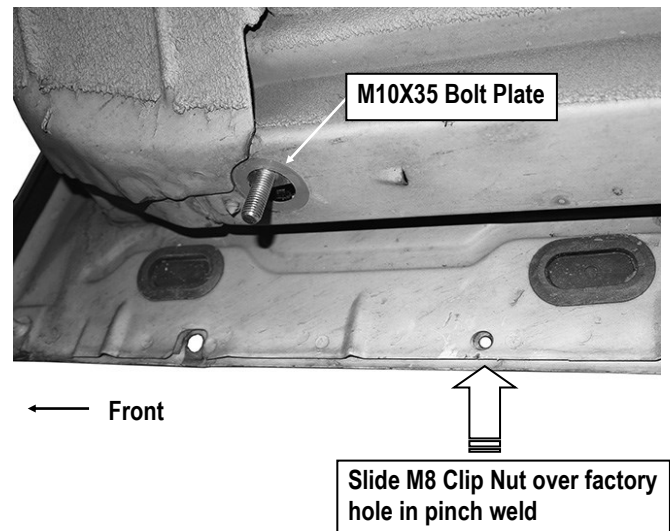

(Fig 10) Passenger Side Front Mounting Location

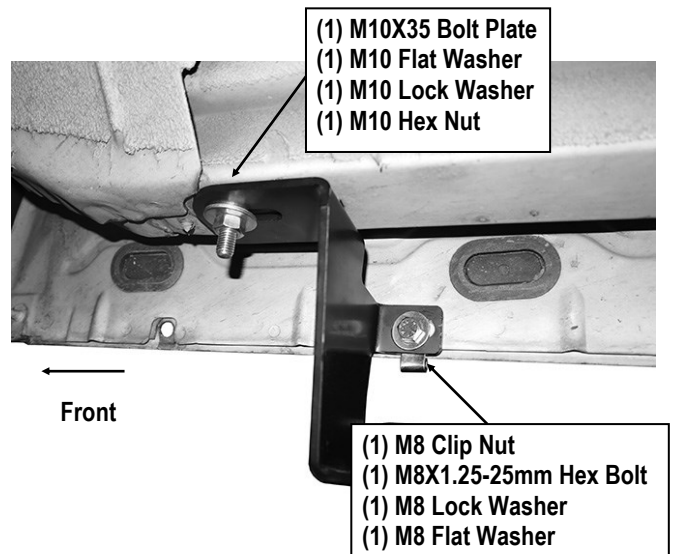

(Fig 11) Passenger Front Mounting Bracket Installation

iBoard®

STEP 8

Move to the 2nd Mounting Bracket location, (Fig 12). Repeat **Step 5** to install the Passenger Center Mounting Bracket (PCM), (Figs 12 & 13). Do not fully tighten hardware at this time.

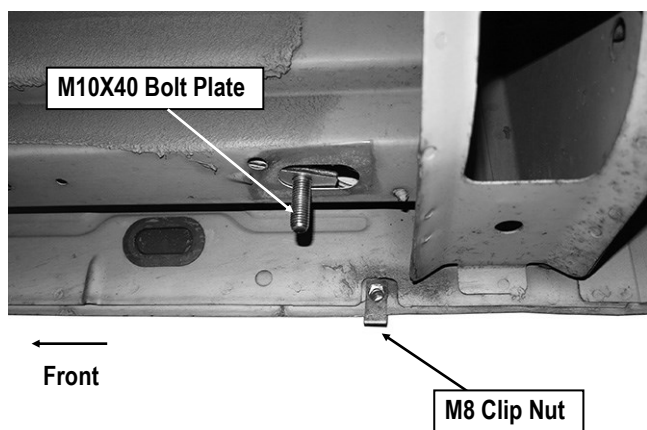

(Fig 12) Passenger Center Mounting Bracket Location

(1) M10X40 Bolt Plate
(1) M10 Flat Washer
(1) M10 Lock Washer
(1) M10 Hex Nut

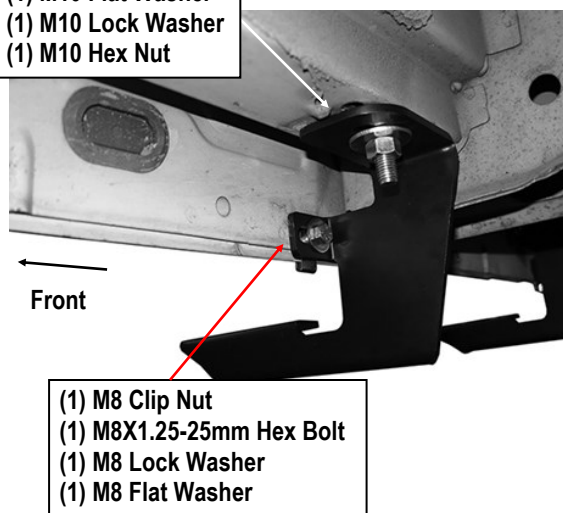

(Fig 13) Passenger Center Mounting Bracket Installation

STEP 9

Move to the 3rd Bracket location below the sliding door, (Fig 14). Determine the correct procedure for your year/model for the remaining (2) passenger side Brackets:

Models with factory holes in pinch weld and inner body panel:

- Locate the factory hole in the pinch weld. Also locate the square hole and small round hole in the inner body panel near and above the hole in the pinch weld, (Fig 14).
NOTE: Hold the appropriate Mounting Bracket up in each location to help determine the correct holes to use.
- Slide (1) M8 Clip Nut into the square hole and in line with the smaller round hole. Next, slide (1) M8 Clip Nut over the hole through the pinch weld as described in **Step 3**, (Fig 14).
- Select the Passenger Center Mounting Bracket 1 (PCM1). Attach the Bracket to the (2) M8 Clip Nuts with (2) M8X1.25-25mm Hex Bolts, (2) M8 Lock Washers and (2) M8 Flat Washers, (Fig 15). Do not fully tighten hardware at this time.
- Move to 4th & 5th mounting bracket locations, repeat **Steps a—c** to install (2) Passenger Rear Mounting Brackets (PRM), (Figs 16-18).

Skip to **Step 10**.

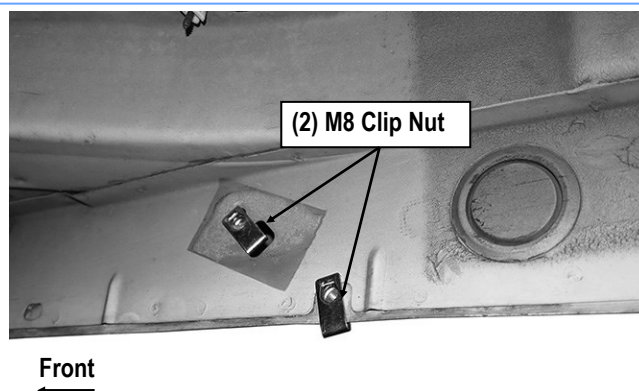

(Fig 14) Passenger Side Center Mounting Bracket 1 Location

iBoard®

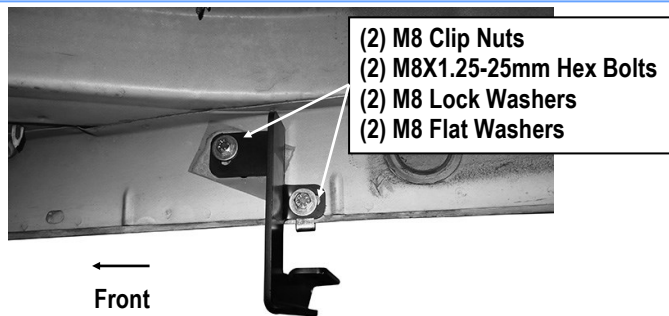

(Fig 15) Passenger Center Mounting Bracket 1 Installation

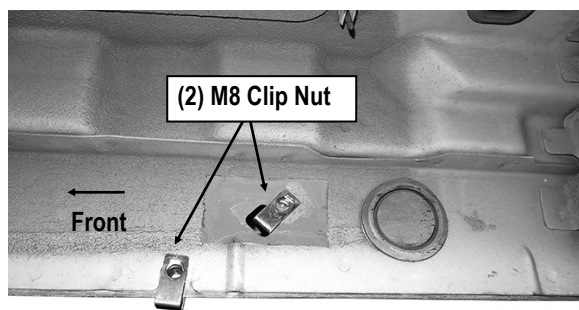

(Fig 16) Passenger Side 4th Mounting Bracket Location

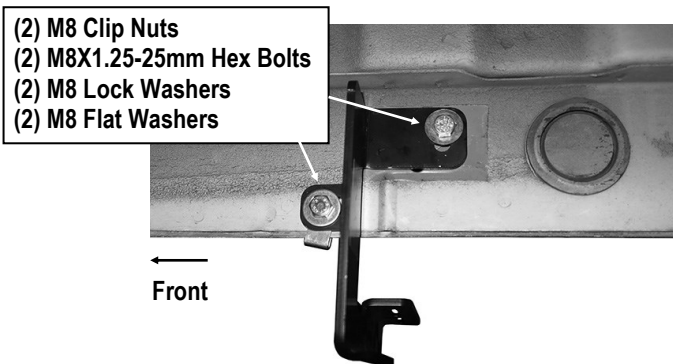

(Fig 17) Passenger 4th Mounting Bracket Installation

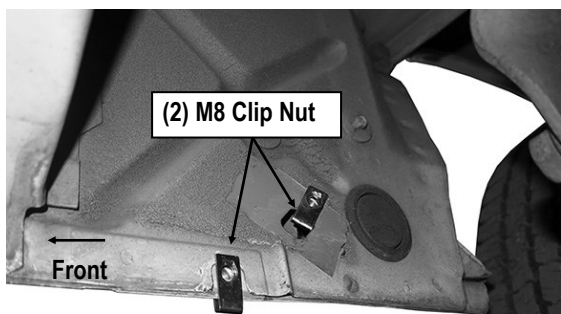

(Fig 18) Passenger 5th Mounting Bracket Installation

Models without factory holes in the pinch weld and/or inner body panel:

- Repeat **Step 7** to attach the Running Board to the front and 2nd Mounting Brackets.
- Use a stand or a jack to hold the Running Board up and level with the front (2) Brackets.
- Select the 3rd Passenger Center Mounting Bracket 1 (**PCM1**). With the Running Board level to the vehicle, hold the Bracket up in position against the back of the pinch weld and body panel. Mark the location of the slots in the Bracket onto the sheet metal, (**Fig 19**). **NOTE:** Use a clamp or locking pliers to temporarily attach the Bracket to the pinch weld.
- Drill a 7/16" hole in the center of the mark for the top mounting tab, (**Fig 19**). **IMPORTANT:** Make sure the Running Board is level to the vehicle before drilling any mounting holes.
- Select (1) M8 Insert Installation Tool, (1) M8X1.25-40mm Hex Bolt, (1) M8 Flat Washer and (1) M8 Rivet Nut. Assemble the Insert as pictured in **Fig 20**. **NOTE:** Select 8 mm hole on Insert Installation Tool (**Fig 21**).
- Firmly hold the handle and push the Rivet Nut into the hole. Use a small hammer to gently tap the insert into the hole if necessary. Once inserted, hold the handle with one hand and turn the M8 Hex Bolt, (tighten), with a wrench to expand the Rivet Nut in the body panel. Continue to tighten the M8 Hex Bolt until the Rivet Nut is fully compressed and close to flush with the surface. Remove bolt and tool from the Rivet Nut, (**Fig 22**). **WARNING:** Do not over tighten the hex bolt or the Rivet Nut may become damaged.
- Repeat **Step 3** to drill the 5/16" hole through the pinch weld as needed.
- Select the passenger side 3rd Mounting Bracket. Attach the Bracket to the M8 Rivet Nut and M8 Clip Nut with (2) M8X1.25-25mm Hex Bolts, (2) M8 Lock Washers and (2) M8 Flat Washers, (**Fig 23**). Do not fully tighten hardware at this time.
- Repeat **Steps a—h** to install the identical 4th & 5th Bracket, (**Figs 24-26**).

iBoard®

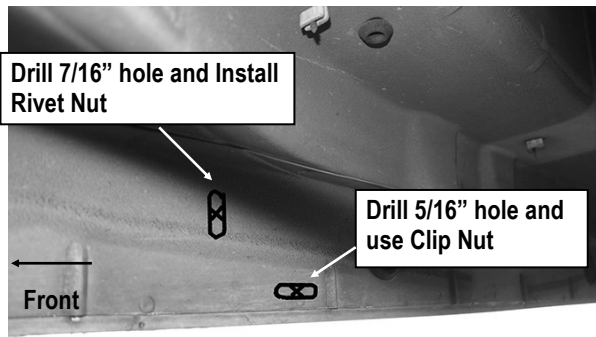

(Fig 19) Passenger 3rd Mounting Bracket Location



(Fig 20) Assemble Insert Tool As Pictured

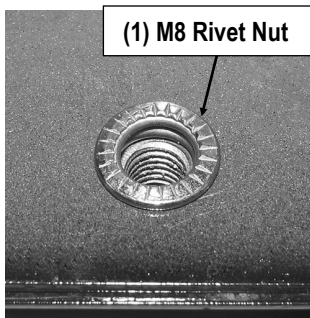

(Fig 22) Example Fully Installed Insert

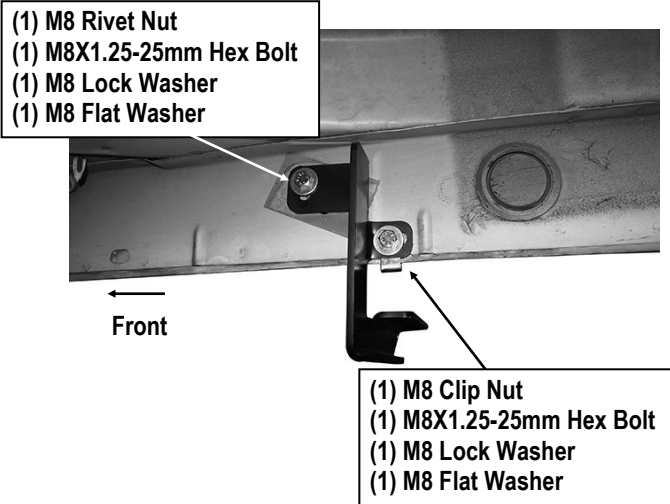

(Fig 23) Passenger 3rd Mounting Bracket Installation

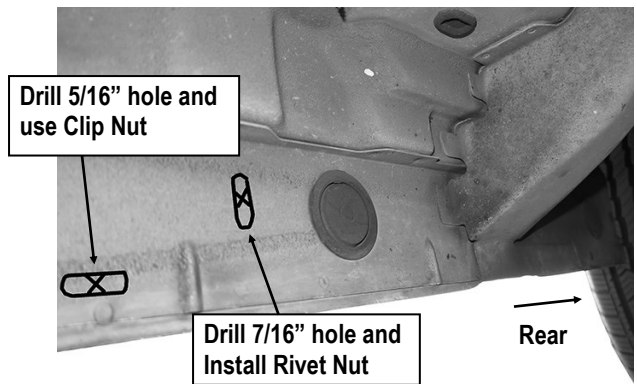

(Fig 24) Passenger 4th Mounting Bracket Location

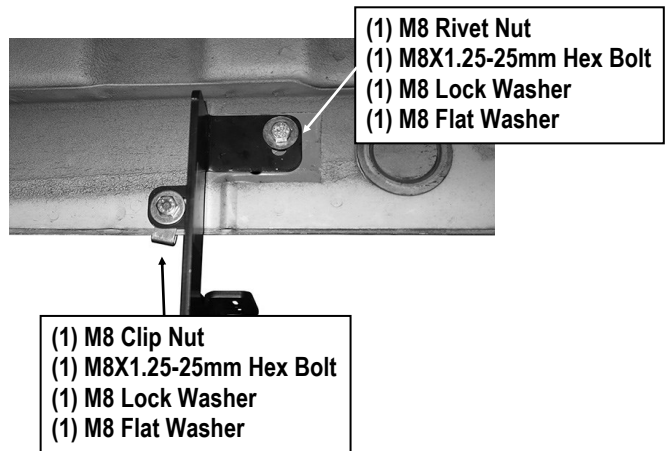

(Fig 25) Passenger 4th Mounting Bracket Installation

iBoard®

STEP 11

Level and adjust the Running Board and fully tighten all hardware. The installation is completed.

Attention

Do periodic inspections to the installation to make sure that all hardware is secure and tight.

In order to protect your bars/boards, please use only mild soap/non-abrasive products for cleaning.

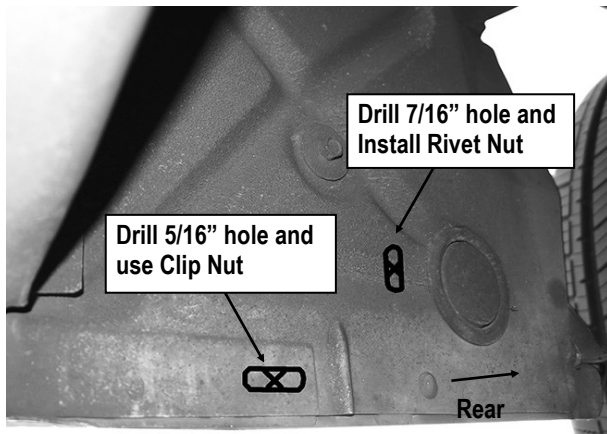

(Fig 26) Passenger 5th Mounting Bracket Location

STEP 10

Select the Passenger Side Running Board. Slip (5) M6x1-20mm Square Head Bolts into each bottom channel, (Fig 8). Carefully position the Running Board onto the (5) Mounting Brackets.

Repeat Step 6 to attach the Running Board to the Mounting Brackets.