

iBoard®

iBoard® by APS

PART#: IB-R310

READ INSTRUCTIONS CAREFULLY BEFORE STARTING INSTALLATION. REMOVE CONTENTS FROM BOX AND VERIFY ALL PARTS ARE PRESENT. ASSISTANCE IS RECOMMENDED.

*ROCKER PANEL MOUNT
*NO DRILLING REQUIRED

Fastener Size	Tightening Torque (ft-lbs)	Required
6mm	6-7	√
8mm	16-18	√
10mm	31-32	√
12mm	56-58	X
14mm	92-94	X

PART LIST

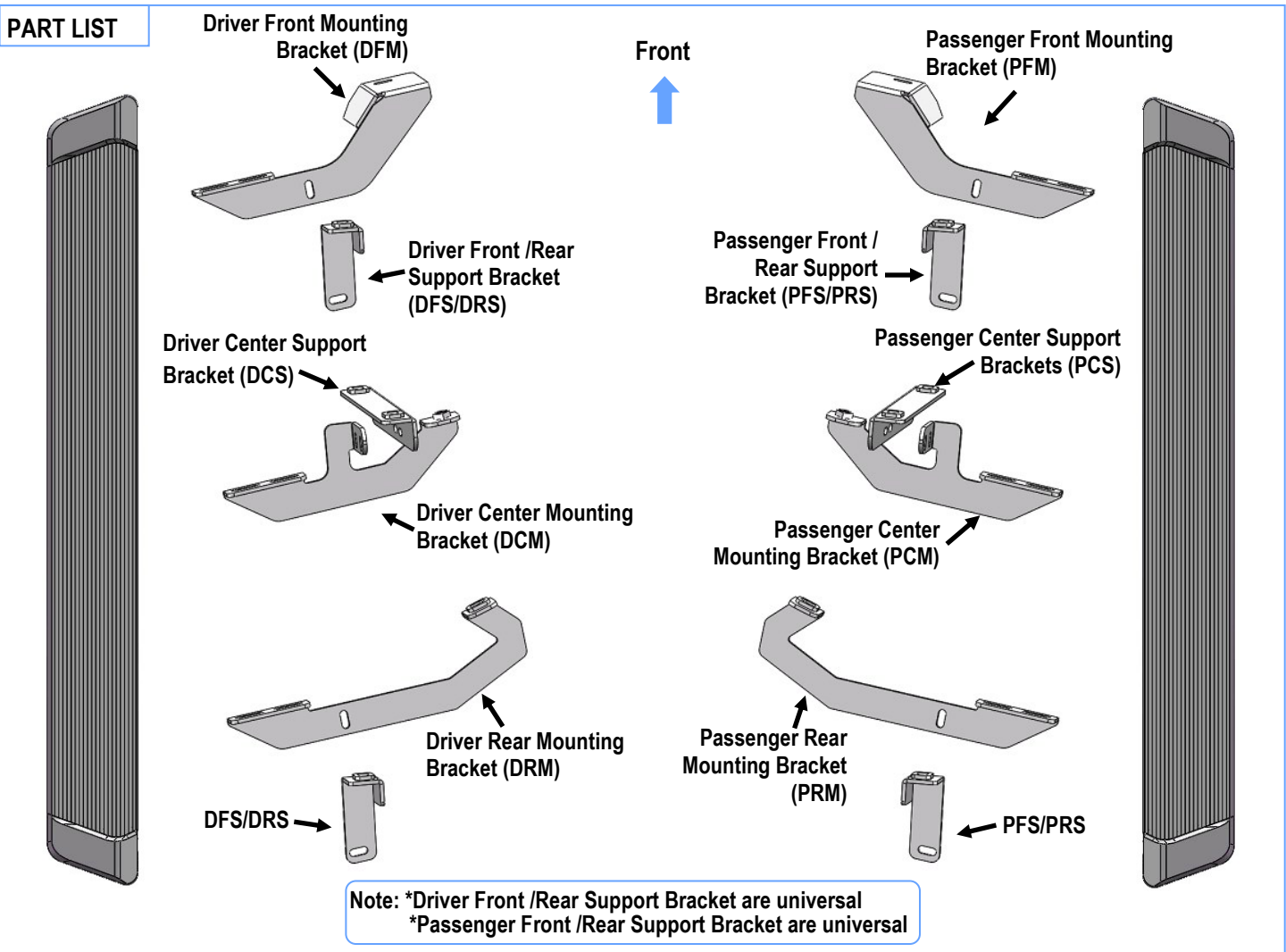

Customer Support: info@iboardauto.com

iBoard®

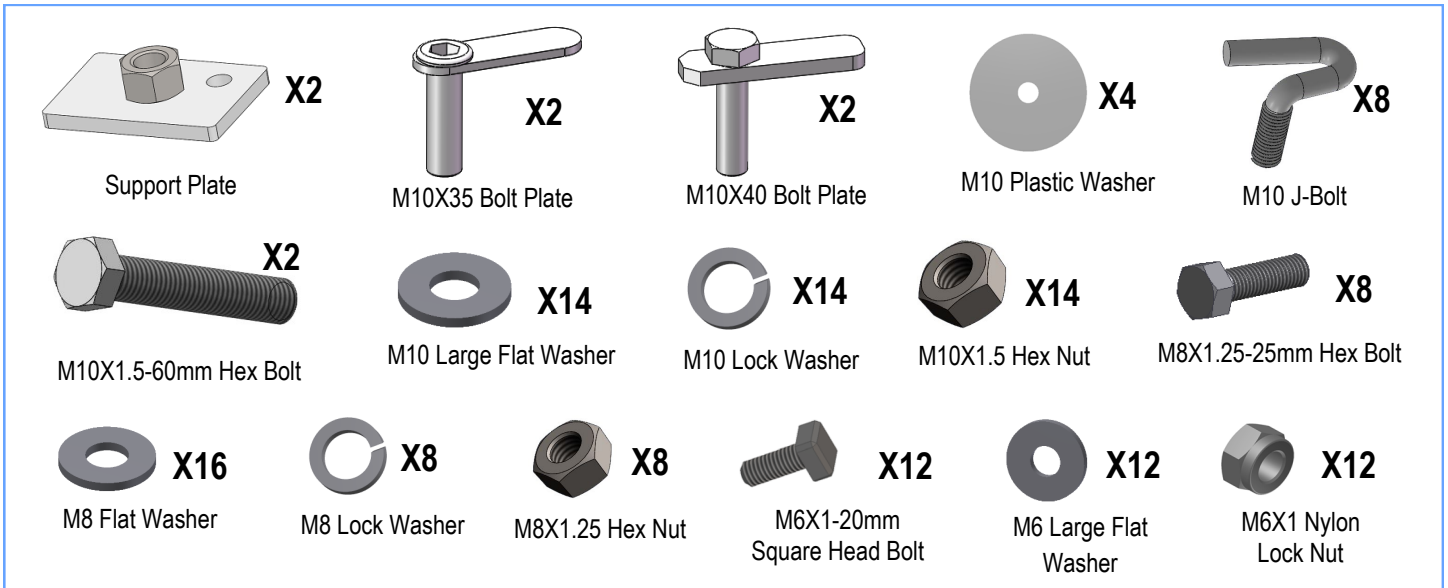

STEP 1

Start the installation from Driver Side Mounting Locations of the vehicle, remove the large plastic cover on the bottom of the floor panel, **(Fig 1)**. Determine which plastic clips need to be removed. Carefully remove only the plastic clips for installation.

Remove plastic trim clips

Front

Remove factory pins and hardware

(Fig 1) Driver Side Front Mounting Location

STEP 2

Locate the Driver Side Front Mounting Location, **(Fig 2)**. Select (1) M10 J-Bolt, insert the M10 J-Bolt into the side panel, **(Fig 3)**.

- With the M10 J-Bolt threads pointing away from the vehicle, insert the tail all the way up into the slot. Keep threads pointed outwards, **(Fig 3a)**.
- Slide in the bend in the tail up into the slot, keeping the threads pointed outwards, **(Fig 3b)**.
- Rotate M10 J-Bolt downwards so that the threads are pointed towards the ground, **(Fig 3c)**.

Select (1) M10X35 Bolt Plate, insert the Bolt Plate into the floor panel, **(Fig 2)**. Thread (1) M10 Plastic Washer onto the Bolt Plate to hold it in place

iBoard®

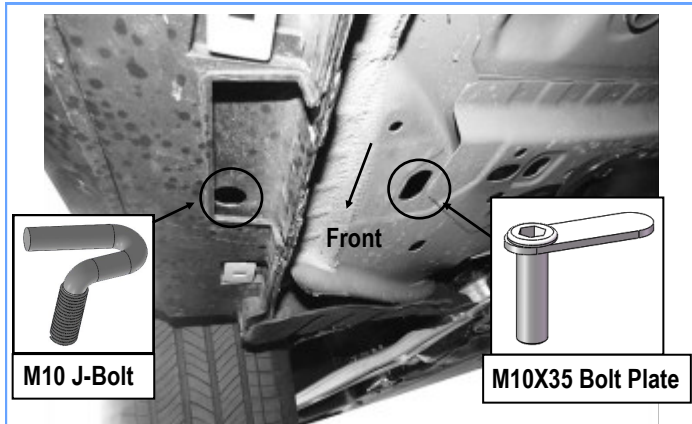

(Fig 2) Driver Side Front Mounting Location



(Fig 3a) Insert (1) M10 J-Bolt



(Fig 3b) Insert (1) M10 J-Bolt



(Fig 3c) Insert (1) M10 J-Bolt

STEP 3

Select the Driver Front Mounting Bracket (**DFM**) and the Driver Front Support Bracket (**DFS/DRS**), assembly with (1) M8X1.25-25mm Hex Bolt, (2) M8 Flat Washers, (1) M8 Lock Washer and (1) M8X1.25 Hex Nut, (**Fig 4**). Do not fully tighten at this time.

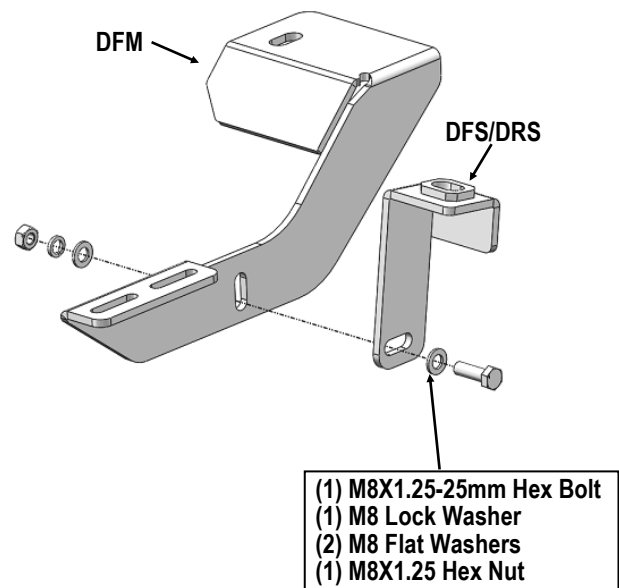

(Fig 4) Driver Side Front Brackets Assembly

STEP 4

Attach the assembled Mounting Bracket to the M10X35 Bolt Plate with (1) M10 Large Flat Washer, (1) M10 Lock Washer and (1) M10X1.5 Hex Nut; attach to the M10 J-Bolt with (1) M10 Large Flat Washer, (1) M10 Lock Washer and (1) M10X1.5 Hex Nut, (**Fig 5**). Do not fully tighten at this time.

iBoard®

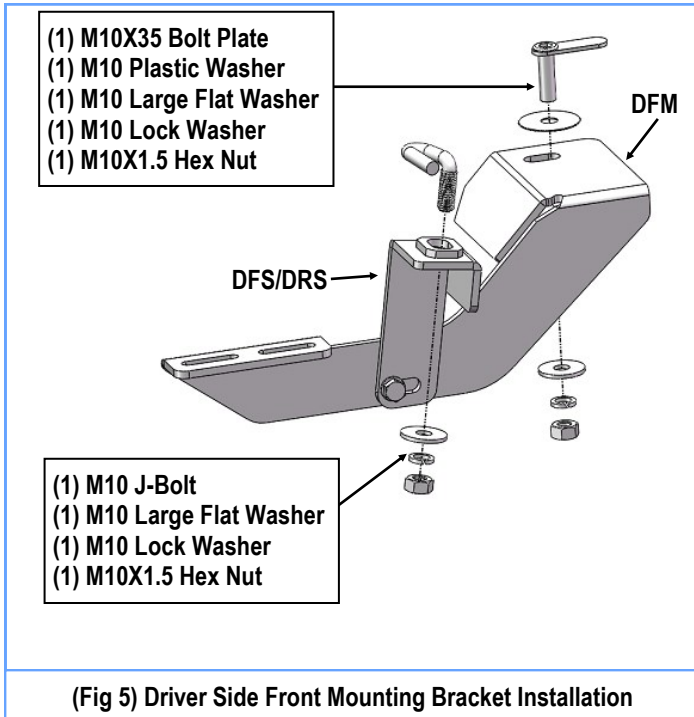

STEP 5

Select the Driver Center Mounting Bracket (**DCM**) and the Driver Center Support Bracket (**DCS**), assembly with (2) M8X1.25-25mm Hex Bolts, (4) M8 Flat Washers, (2) M8 Lock Washers and (2) M8X1.25 Hex Nuts, (**Fig 6**). Do not fully tighten at this time.

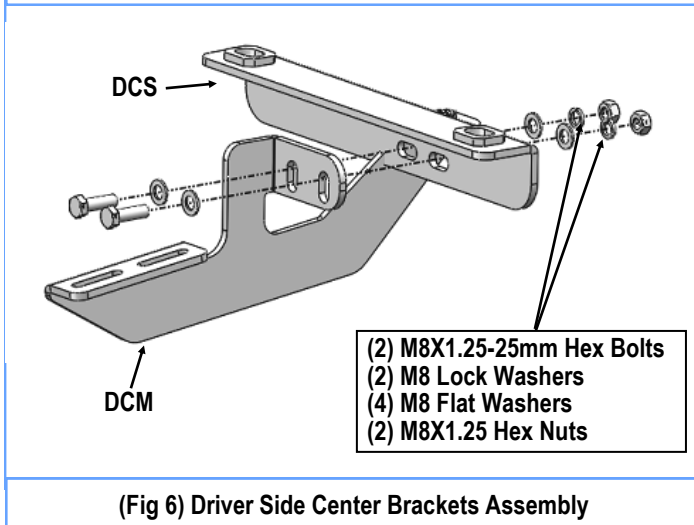

STEP 6

Move to the Driver Side Center Mounting Location, (**Fig 7**). Insert (2) M10 J-Bolts into the side panel, (**Fig 8**). Attach the Driver Center Support Bracket to the (2) M10 J-Bolts with (2) M10 Large Flat Washers, (2) M10 Lock Washers and (2) M10X1.5 Hex Nuts, (**Fig 9**). Do not fully tighten at this time.

Select (1) Support Plate.

- Thread (1) M10X1.5 Hex Nut to (1) M10X1.5-60mm Hex Bolt. Slide (1) M10 Lock Washer and (1) M10 Flat washer onto the M10X1.5-60mm Hex Bolt. **NOTE:** Use the M10X1.5 Hex Nut to adjust the level of the Mounting Bracket.
- Thread the M10 Hex Bolt assembly into the welded nut on the back of the Mounting Bracket. Place the Support Plate onto the end of the M10 Hex Bolt, (**Fig 9**).
- Tighten Hex Bolt to place the Support Plate onto the floor panel. Do not tighten Hex Bolt all the way.
- Follow link for Support Plate installation.

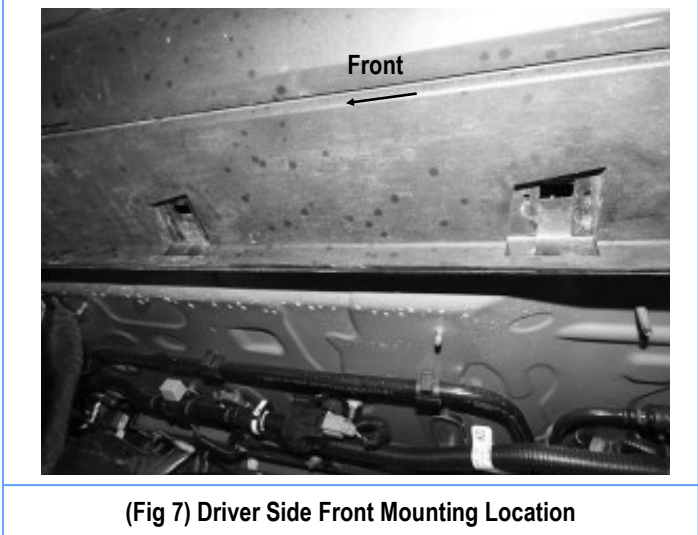

STEP 7

Move to the Driver Side Rear Mounting Location, (**Fig 10**). Repeat **Steps 2- 4** to attach the Driver Rear Mounting Brackets, (**Figs 10—13**). Do not fully tighten hardware.

iBoard®

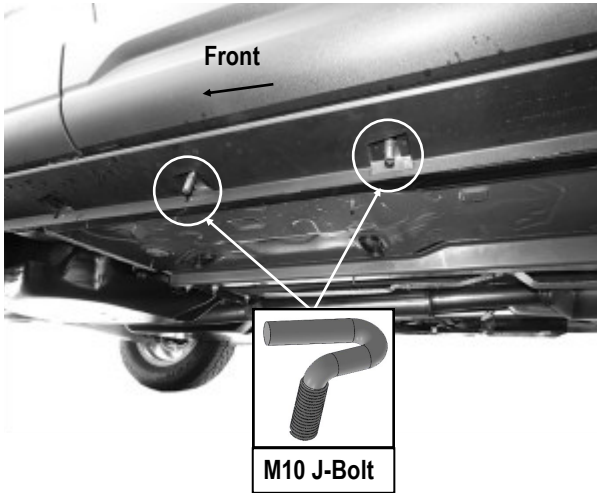

(Fig 8) Insert (2) M10 J-Bolts

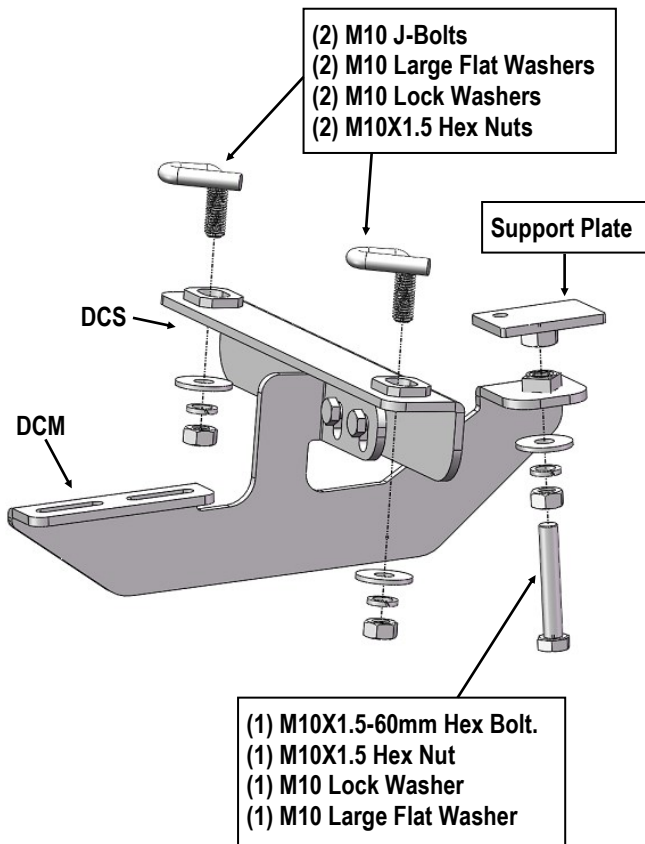

(Fig 9) Driver Side Center Brackets Installation

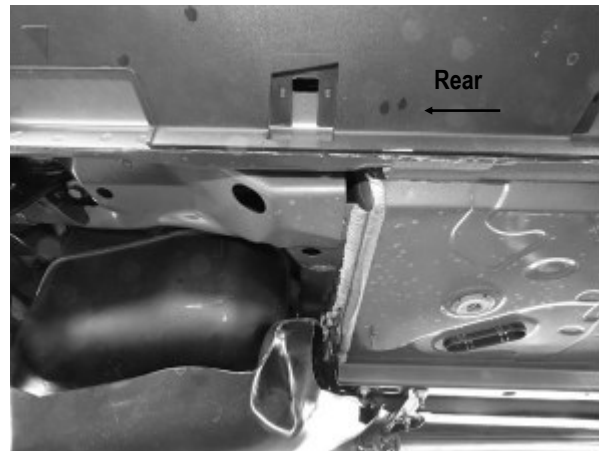

(Fig 10) Driver Side Rear Mounting Location

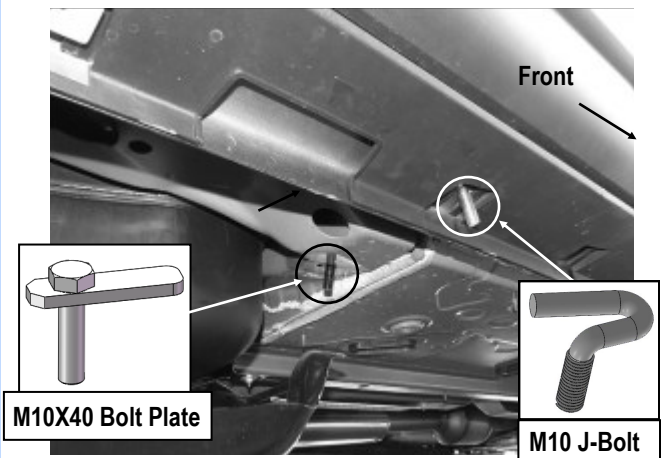

(Fig 11) Insert (1) M10 J-Bolt And (1) M10X40 Bolt Plate

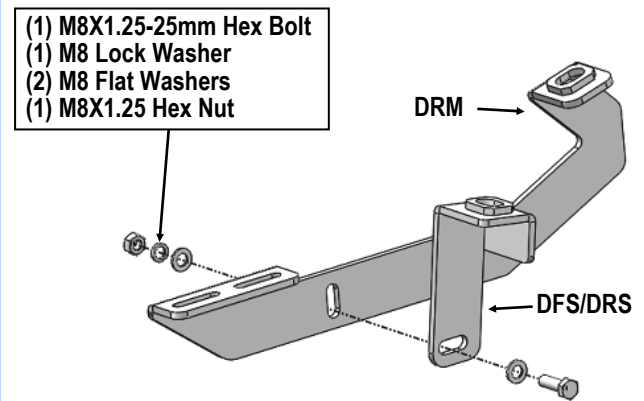

(Fig 12) Driver Side Center Brackets Assembly

iBoard®

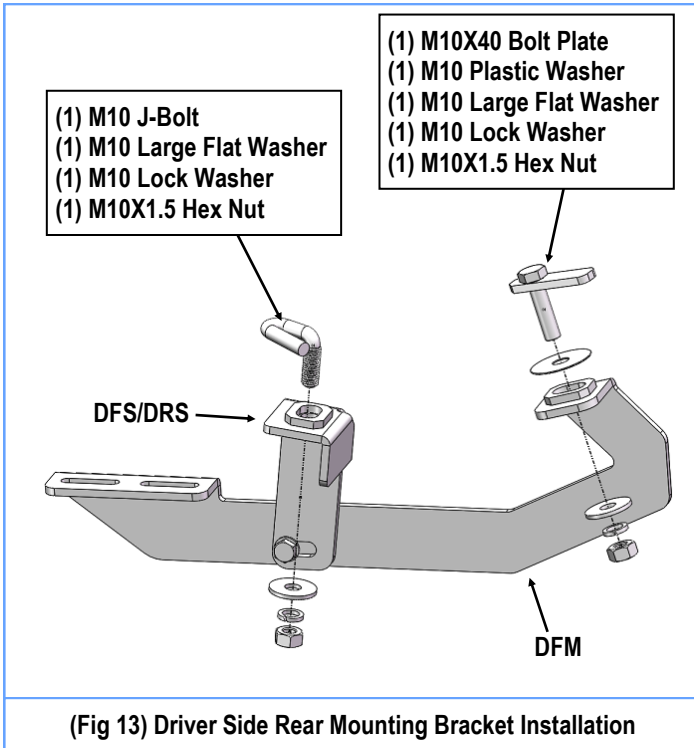

STEP 8

Select a Running Board. Slip (3) M6x1-20mm Square Head Bolts into each bottom channel (Fig 14). Carefully position the Running Board onto the (3) Mounting Brackets.

IMPORTANT: Do not slide the Running Board on the Brackets or the bottom surface of the board will be damaged. Attach the Running Board to each Mounting Bracket with (2) M6x1-20mm Square Head Bolts, (2) M6 Large Flat Washers and (2) M6x1 Nylon Lock Nuts (Fig 15). Do not fully tighten at this time.

Level and adjust the Running Board and fully tighten all hardware.

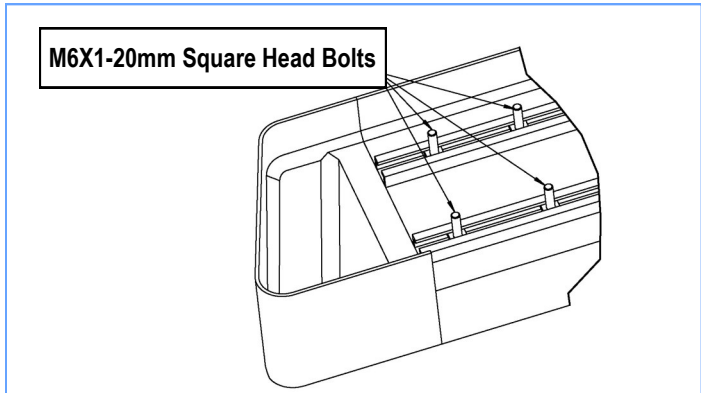

(Fig 14) Slip M6X1-20mm Square Head Bolts Into The Bottom Channels

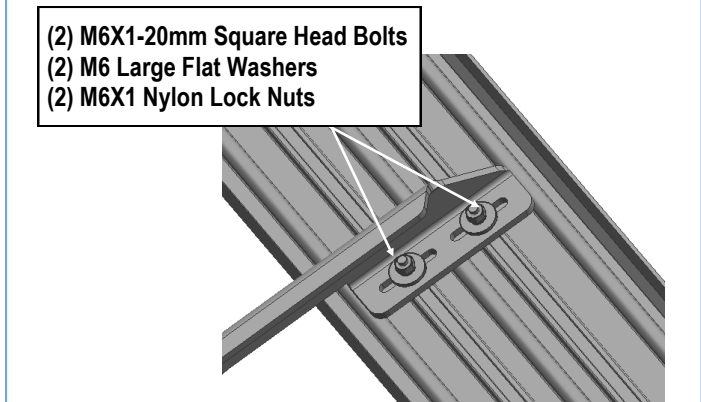

(Fig 15) Running Board Installed Onto Mounting Bracket

STEP 9

Repeat **Steps 1-8** for the other side Running Board installation. The installation is completed.

Attention
Do periodic inspections to the installation to make sure that all hardware is secure and tight.

In order to protect your bars/boards, please use only mild soap/non-abrasive products for cleaning.