

iBoard®

iBoard® by APS

PART#: IB-R213

READ INSTRUCTIONS CAREFULLY BEFORE STARTING INSTALLATION. REMOVE CONTENTS FROM BOX AND VERIFY ALL PARTS ARE PRESENT. ASSISTANCE IS RECOMMENDED.

*ROCKER PANEL MOUNT
*DRILLING MAY BE REQUIRED

Fastener Size	Tightening Torque (ft-lbs)	Required
6mm	6-7	√
8mm	16-18	X
10mm	31-32	√
12mm	56-58	X
14mm	92-94	X

PART LIST

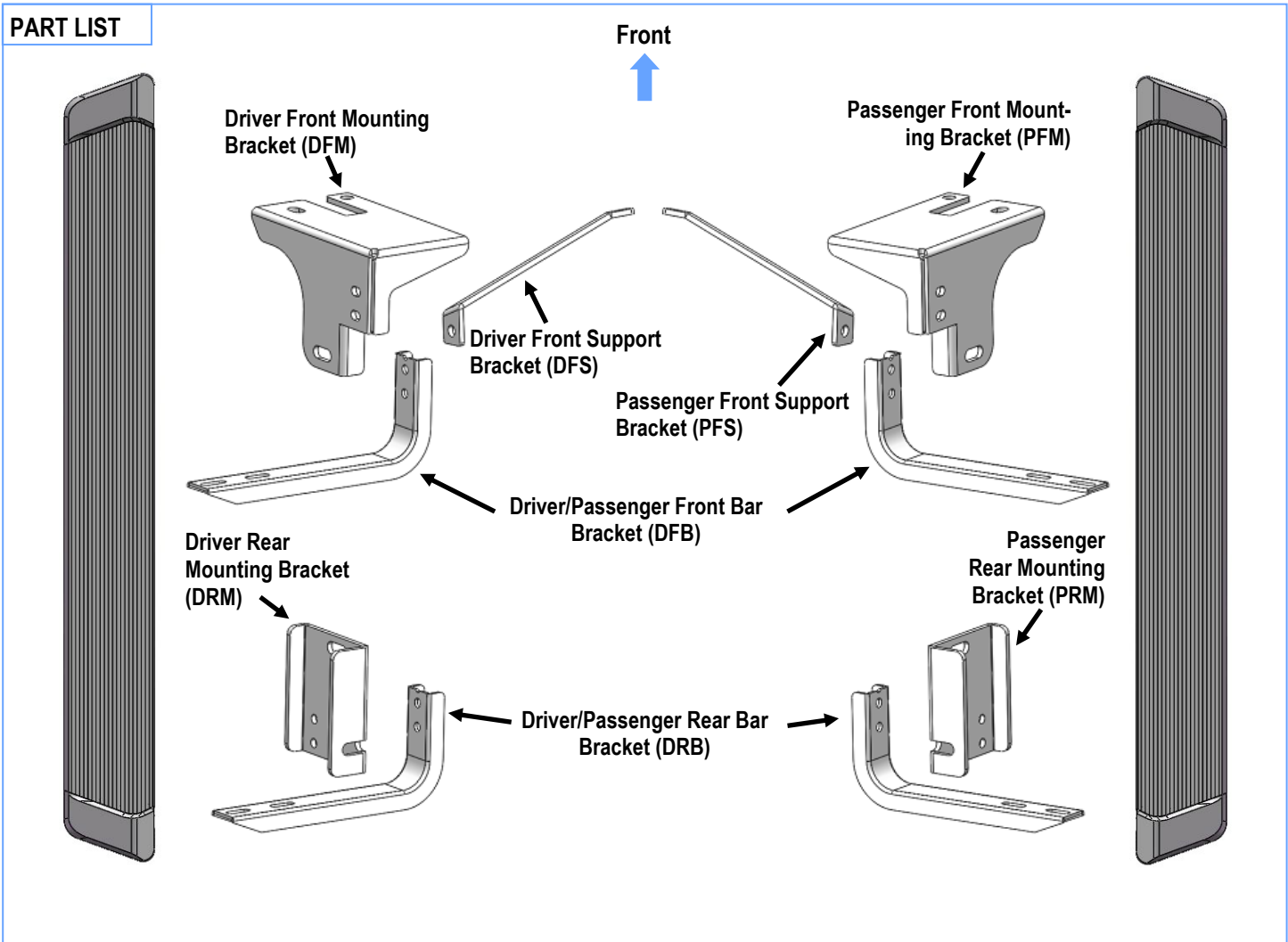

Customer Support: info@iboardauto.com

iBoard®



X1

M10 Driver Double
Nut Plate



X1

M10 Passenger Double
Nut Plate

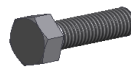

X12

M10X1.5-30mm Hex
Bolt



X20

M10 Flat Washer



X12

M10 Lock Washer



X8

M10 Hex Nut



X8

M8X1.25-20mm
Inner Hex Bolt



X8

M8 Hex
Flange Nut

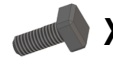

X8

M6X1-20mm Square
Head Bolt



X8

M6 Large Flat
Washer



X8

M6 Nylon Lock
Nut

STEP 1

Start the installation under the passenger side front of the vehicle. Locate the (3) factory holes (one large, two small) in the frame channel next to the front body mount. Insert the smaller end of the M10 Passenger Double Nut Plate through the large hole in the frame and line it up with the smaller hole, (**Fig 1**).

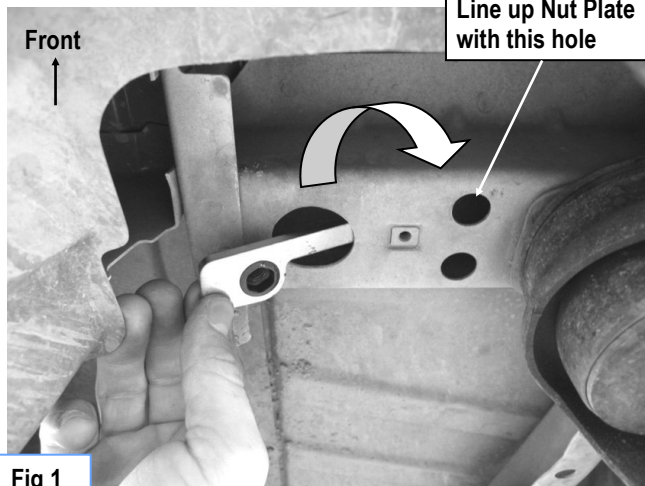
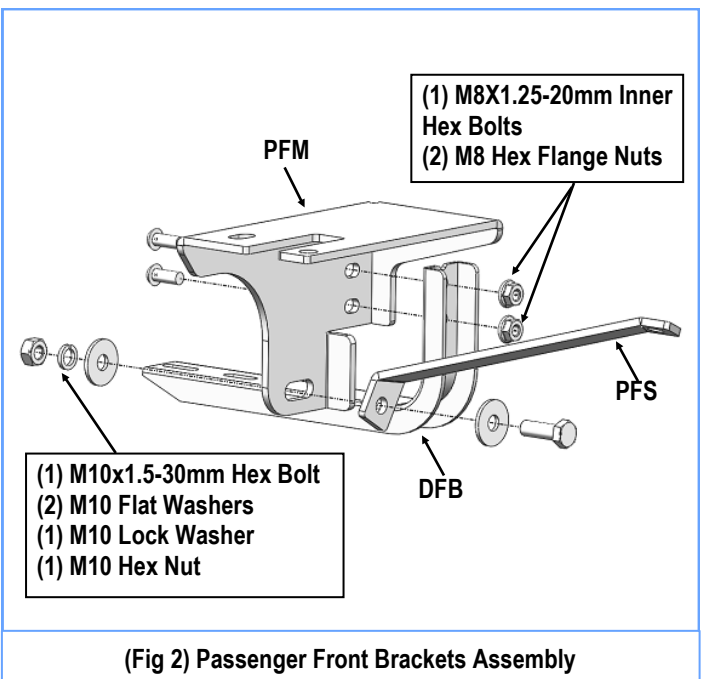

Fig 1

STEP 2

Select the Passenger Front Mounting Bracket (**PFM**) and the Passenger Front Bar Bracket (**DFB**), assembly with (2) M8X1.25-20mm Inner Hex Bolts and (2) M8 Hex Flange Nuts, (**Fig 2**). Do not fully tighten at this time.



(Fig 2) Passenger Front Brackets Assembly

STEP 3

Hang the Passenger Front Mounting Bracket to the installed M10 Double Nut Plate with the included (2) M10X1.5-30mm Hex Bolts, (2) M10 Lock Washers and (2) M10 Flat Washers, (**Fig 3**). Do not fully tighten hardware at this time.

iBoard®

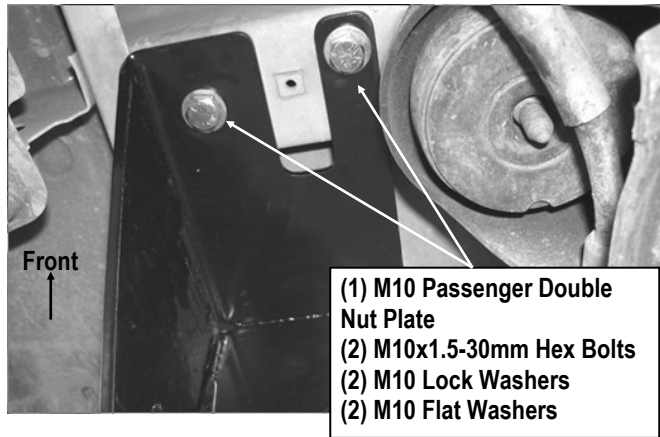

(Fig 3) Passenger Front Mounting Bracket Installed

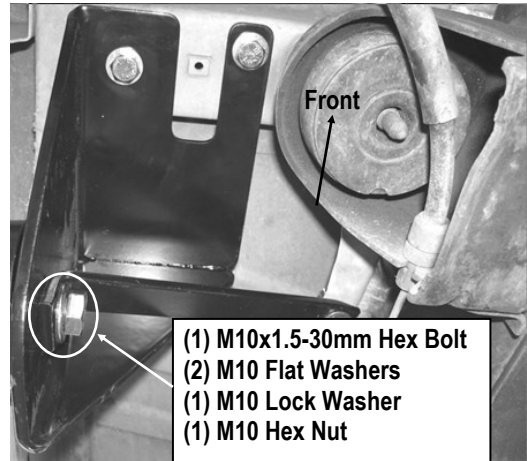

(Fig 5) Passenger Front Support Bracket attached to Passenger Front Mounting Bracket

STEP 4

Locate the factory hole on the edge of the floor panel behind the passenger front body mount. Select the Passenger Front Support Bracket (**PFS**). Bolt the flat end of the Support Bracket to the factory hole using the included (1) M10 x 1.5-30mm Hex Bolt, (1) M10 Lock Washer, (2) M10 Flat Washers and (1) M10 Hex Nut, (**Fig 4**).

Line up the bent end of the Support Bracket with the back of the Passenger Front Mounting Bracket (**PFM**). Bolt the Support Bracket using the included (1) M10 x 1.5-30mm Hex Bolt, (1) M10 Lock Washer, (2) M10 Flat Washers and (1) M10 Hex Nut, (**Figs 2 & 5**). Do not fully tighten hardware at this time.

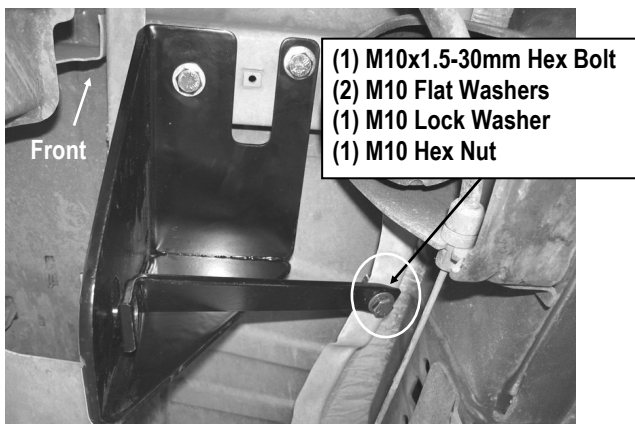

(Fig 4) Passenger Front Support Bracket Installation

STEP 5

Select the Passenger Rear Mounting Bracket (**PRM**) and the Passenger Rear Bar Bracket (**DRB**), assembly with (2) M8X1.25-20mm Inner Hex Bolts and (2) M8 Hex Flange Nuts, (**Fig 6**). Do not fully tighten at this time.

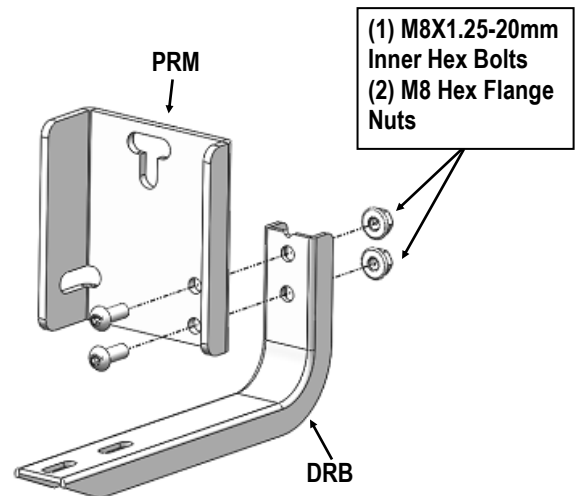

(Fig 6) Passenger Side Rear Brackets Assembly

iBoard®

STEP 6

Move to the Passenger Side Rear Mounting Location of the vehicle. Insert the Passenger Rear Mounting Bracket (PRM) between the inner side panel and the outer body of the vehicle, (Figs 7 & 8).

Line up the hole in the 90° bend with the factory hole in the cab toward the bed and secure it using the included (1) M10x1.5-30mm Hex Bolt, (1) M10 Lock Washer, (2) M10 Flat Washers and (1) M10 Hex Nut.

Attach the upper mounting location in the Rear Bracket to factory hole in the inner side panel using the included (1) M10x1.5-30mm Hex Bolt, (1) M10 Lock Washer, (2) M10 Flat Washers and (1) M10 Hex Nut, (Figs 7 & 8). Do not fully tighten hardware at this time.

NOTE: On some models, it may be necessary to drill a hole through the side panel for the hex bolts.

IMPORTANT: Any cutting or drilling tool may break or shatter. Government regulations require safety glasses & equipment at all times when cutting or drilling.

(1) M10x1.5-30mm Hex Bolt
(1) M10 Lock Washer
(2) M10 Flat Washers
(1) M10 Hex Nut

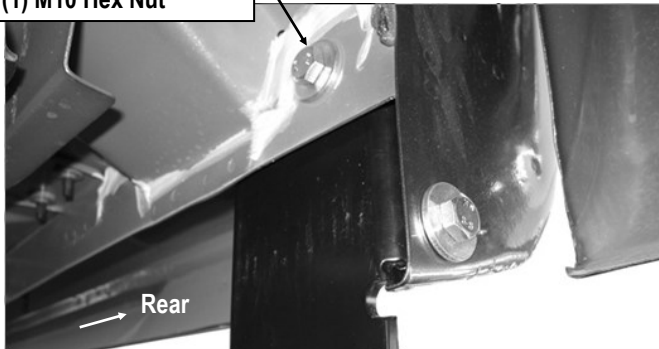

(Fig 7) Passenger Rear Mounting Bracket Installation

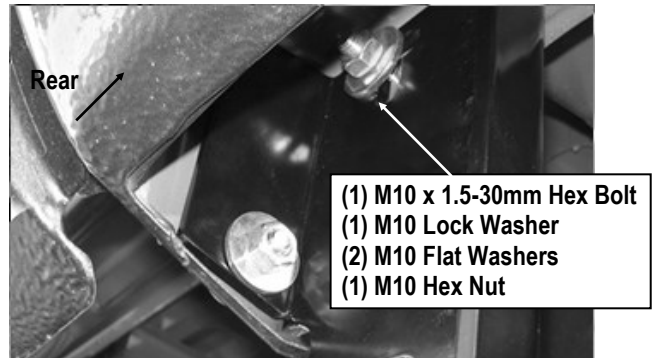

(Fig 8) Passenger Rear Mounting Bracket Installation

STEP 7

Select a Running Board. Slip (2) M6x1-20mm Square Head Bolts into each bottom channel (Fig 9). Carefully position the Running Board onto the (2) Mounting Brackets.

IMPORTANT: Do not slide the Running Board on the Brackets or the bottom surface of the board will be damaged. Attach the Running Board to Mounting Bracket with (2) M6x1-20mm Square Head Bolts, (2) M6 Large Flat Washers and (2) M6 Nylon Lock Nuts (Fig 10). Do not fully tighten at this time.

M6X1-20mm Square Head Bolts

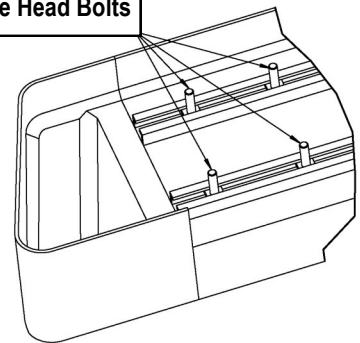

(Fig 9) Slip M6X1-20mm Square Head Bolts Into The Bottom Channels

iBoard®

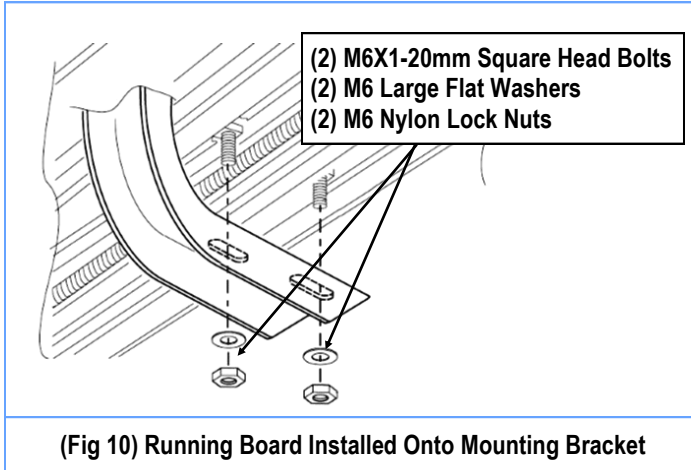

STEP 8

Level and adjust the Running Board and fully tighten all hardware.

Important: Please follow the recommended Tightening Torques shown in the table on page 1. Don't over tighten, or the nuts/bolts will be damaged.

STEP 9

Repeat **Steps 1-8** for the other side Running Board installation. The installation is completed.

Attention

Do periodic inspections to the installation to make sure that all hardware is secure and tight.

In order to protect your bars/boards, please use only mild soap/non-abrasive products for cleaning.