

# iBoard®

## iBoard® by APS

PART#: IB-R188&R189A-B

**READ INSTRUCTIONS CAREFULLY BEFORE STARTING INSTALLATION. REMOVE CONTENTS FROM BOX AND VERIFY ALL PARTS ARE PRESENT. ASSISTANCE IS RECOMMENDED.**

**\*ROCKER PANEL MOUNT  
\*NO DRILLING REQUIRED**

Fastener Size	Tightening Torque (ft-lbs)
6mm	6-7
8mm	16-18
10mm	31-32
12mm	56-58
14mm	92-94

### PART LIST

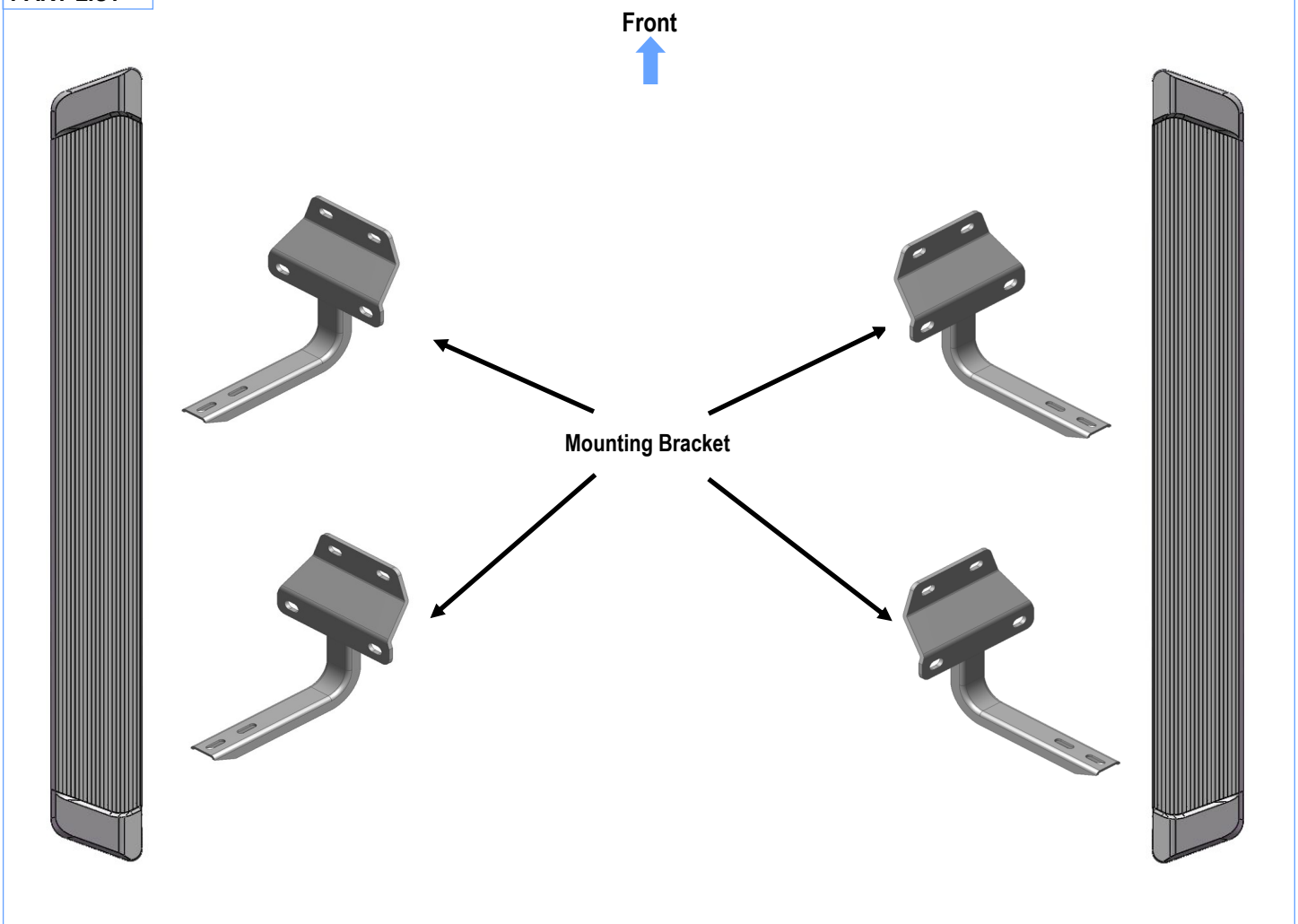

Customer Support: [info@iboardauto.com](mailto:info@iboardauto.com)

# iBoard®

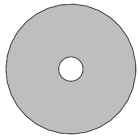

X12

Plastic Washer



X12

M8 Large Flat Washer



X12

M8X1.25 Nylon  
Lock Nut



X8

M6X1-20mm Square  
Head Bolt



X8

M6 Large Flat  
Washer



X8

M6X1 Nylon  
Lock Nut

## STEP 1

Start installation from the passenger side front of the vehicle. Locate the front factory running board mounting location along the inner side of the body panel, (Fig 1).

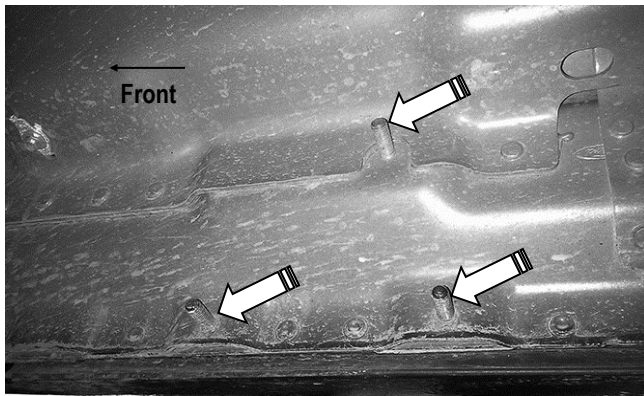

(Fig 1) Passenger Side Front Mounting Location

## STEP 2

Slide (1) Plastic Washer over each factory mounting stud in the body panel, (Fig 2).

**Note:** The Plastic Washers are designed to prevent corrosion between the aluminum body panel and the steel mounting brackets.

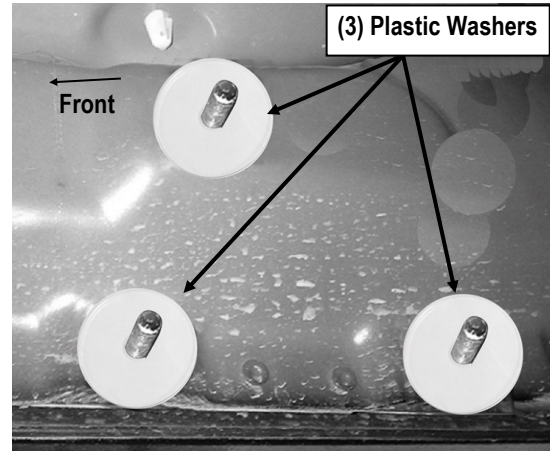

(Fig 2) Thread Plastic Washers Onto 3 Mounting Studs  
(Passenger Side Front Mounting Location Pictured)

## STEP 3

Select (1) Mounting Bracket. **Note:** All (4) Mounting Brackets are universal. Attach the Mounting Bracket to the (3) factory studs with (3) M8 Large Flat Washers and (3) M8X1.25 Nylon Lock Nuts, (Fig 3). Do not fully tighten hardware at this time.

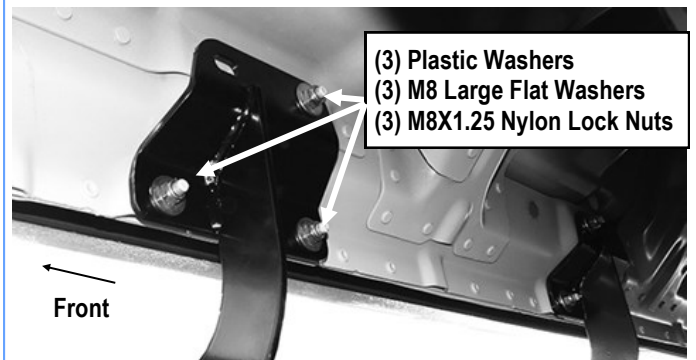

(Fig 3) Passenger Front Mounting Bracket Installed

# iBoard®

## STEP 4

Move to the Passenger Side Rear Mounting Location. Repeat **Steps 1—3** to install the Passenger Side Rear Mounting Bracket. Do not fully tighten at this time.

## STEP 5

Select a Running Board. Slip (2) M6X1-20mm Square Head Bolts into each bottom channel (**Fig 4**). Carefully position the Running Board onto the (2) Mounting Brackets.

**IMPORTANT:** Do not slide the Running Board on the Brackets or the bottom surface of the board will be damaged. Attach the Running Board to each Mounting Brackets with (2) M6x1-20mm Square Head Bolts, (2) M6 Large Flat Washers and (2) M6 X1 Nylon Lock Nuts (**Fig 5**). Do not fully tighten at this time.

M6X1-20mm Square Head Bolts

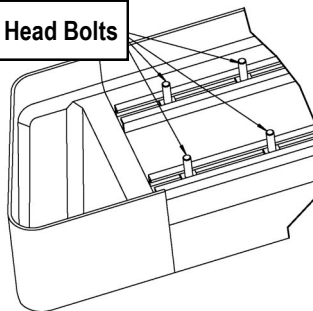

(Fig 4) Slip (2) M6X1-20mm Square Head Bolts Into Each Bottom Channel

(2) M6X1-20mm Square Head Bolts  
(2) M6 Large Flat Washers  
(2) M6X1 Nylon Lock Nuts

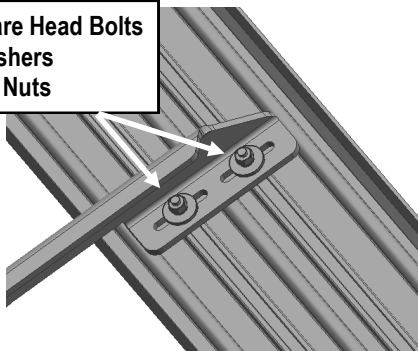

(Fig 5) Running Board Installed Onto Mounting Bracket

## STEP 6

Level and adjust the Running Board and fully tighten all hardware.

## STEP 7

Repeat **Steps 1-6** for the other side Running Board installation. The installation is completed (**Fig 6**).



(Fig 6) Installation Completed

### Attention

Do periodic inspections to the installation to make sure that all hardware is secure and tight.

In order to protect your bars/boards, please use only mild soap/non-abrasive products for cleaning.