

# iBoard®



Scan for  
Installation Video

## iBoard® by APS

PART#: IB-005C&H

READ INSTRUCTIONS CAREFULLY BEFORE STARTING INSTALLATION. REMOVE CONTENTS FROM BOX AND VERIFY ALL PARTS ARE PRESENT. ASSISTANCE IS RECOMMENDED.

\*ROCKER PANEL MOUNT  
\*NO DRILLING REQUIRED

Fastener Size	Tightening Torque (ft-lbs)	Required
6mm	6-7	X
8mm	16-18	√
10mm	31-32	X
12mm	56-58	X
14mm	92-94	X

### PART LIST

#### Driver Side Step Bar

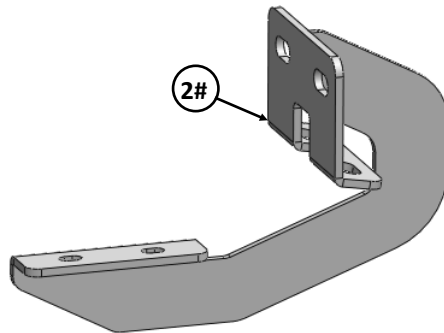
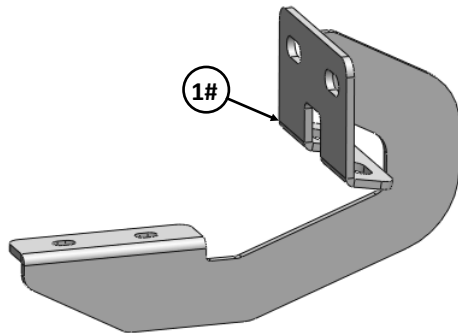
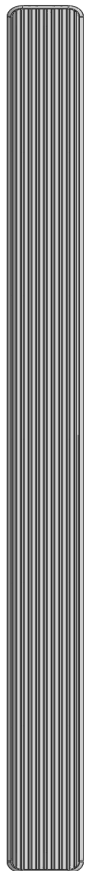

#### Front



#### Passenger Side Step Bar

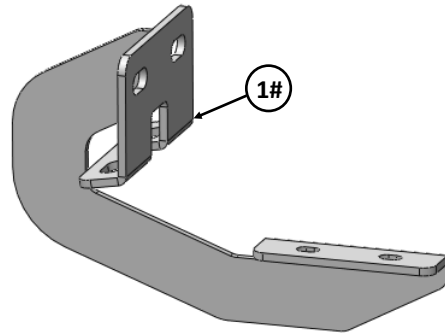
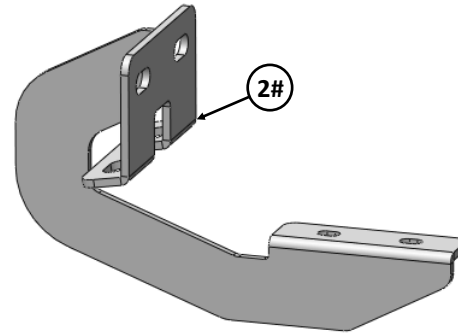
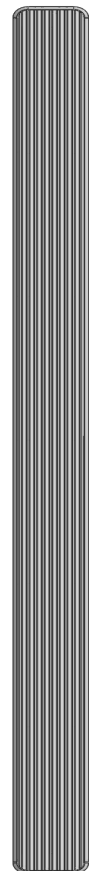



Customer Support: [info@iboardauto.com](mailto:info@iboardauto.com)





Mounting Bracket List					
Item	QTY	Description	Item	QTY	Description
1#	2	Driver Front / Passenger Rear Mounting Brackets	2#	2	Passenger Front / Driver Rear Mounting Brackets

Hardware Package A (For Bracket Installation)					
Item	QTY	Description	Item	QTY	Description
1#	16	M8X1.25-30mm Hex Bolts	4#	8	M8X1.25 Hex Nuts
2#	24	M8 Flat Washers	5#	8	M8 Clip Nuts
3#	16	M8 Lock Washers			

 1 #

 2 #

 3 #

 4 #

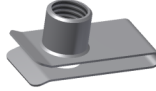
 5 #

Hardware Package B (For Stainless Steel Step Bar Installation)					
Item	QTY	Description	Item	QTY	Description
1#	8	M8X1.25-35mm Carriage Bolts	3#	8	M8 Nylon Lock Nuts
2#	8	M8 Large Flat Washers	4#	4	Sliders (Packed with Step Bars)

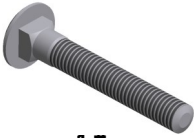
 1 #

 2 #

 3 #

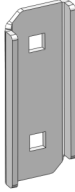
 4 #



## STEP 1

Starting installation on the passenger side of the vehicle, locate the (2) holes in the bottom of the body panel, (pinch weld), Next, locate the rectangular opening with (2) small holes on side along the inner of body panel above the holes in the pinch weld, (Fig 1 & 2). **NOTE:** The holes on the inner of body panel may be covered with sealing tape or insulation.

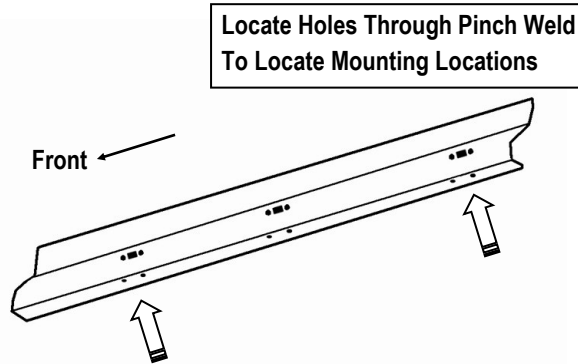

(Fig 1) Passenger Side Mounting Locations

## STEP 2

Start installation from the Passenger Side Front Mounting Location. Slide (2) M8 Clip Nuts into the rectangular opening with the nut towards the inside. Line up the threaded nut on the clip nut with the round hole, (Fig 2).

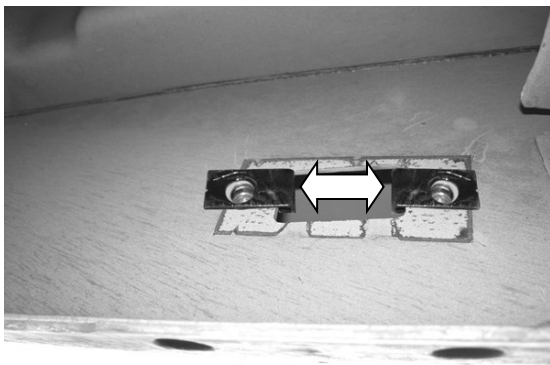

(Fig 2) M8 Clip Nuts Installed

## STEP 3

Select (1) Passenger Front Mounting Bracket, attach the Mounting Bracket to the installed (2) M8 Clip Nuts with the included (2) M8x1.25-30mm Hex Bolts, (2) M8 Lock Washers and (2) M8 Flat Washers, (Figs 3 & 4). Do not fully tighten hardware at this time.

(2) M8 x 1.25-30mm Hex Bolts  
(2) M8 Lock Washers  
(2) M8 Flat Washers

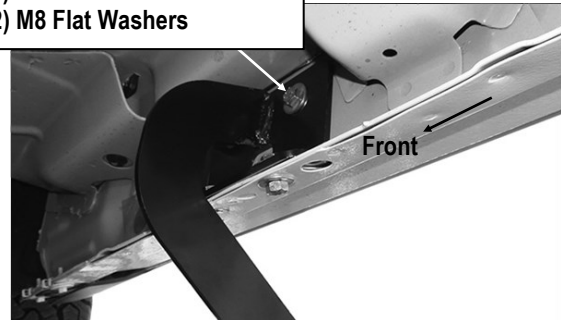

(Fig 3) Passenger Front Mounting Bracket Installed

## STEP 4

Align the lower mounting holes in the bracket with the (2) holes in the pinch weld. Bolt the Bracket to the pinch weld using the included (2) M8x1.25-30mm Hex Bolts, (4) M8 Flat Washers, (2) M8 Lock Washers and (2) M8x1.25 Hex Nuts, (Fig 4). **NOTE:** Insert the bolts up from the bottom of the pinch weld and through the Bracket. Do not fully tighten at this time.

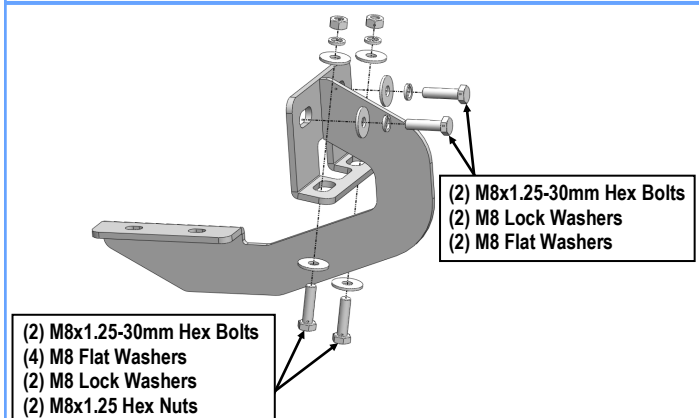

(Fig 4) Passenger Front Mounting Bracket Installation



## STEP 5

Move to the Passenger Side Rear Mounting Location, (**Fig 1**). Repeat **Steps 2—5** for Passenger Rear Mounting Bracket installation.

## STEP 6

Once all (2) Passenger side mounting brackets are installed, then proceed to the Step Bar installation. (**Figs 5 & 6**)

- (1) Select (1) Slider and (2) M8X1.25-35mm Carriage Bolts;
- (2) Install (2) M8X1.25-35mm Carriage Bolts in (1) Slider.
- (3) Slide the Slider (with carriage bolts) to the **Step Bar**.
- (4) Repeat to install the other (1) slider to the step bar.
- (5) Attach the Step Bar (with the Sliders) onto the installed mounting brackets. Position the Sliders to the installed bracket-

ets. Secure the Step Bar to the installed Brackets by using (4) M8 Large Flat Washers and (4) M8 Nylon Lock Nuts and (2) Sliders, (**Fig 6**). Do not fully tighten hardware at this time.

**Note:** The Sliders are packed with the Step Bars.

Level and adjust the Step Bar and fully tighten all hardware.

Repeat **Steps 1-6** for the other side Step Bar installation. **The installation is completed!!!**

### Attention

Do periodic inspections to the installation to make sure that all hardware is secure and tight.

In order to protect your bars/boards, please use mild soap/non-abrasive products for cleaning only.

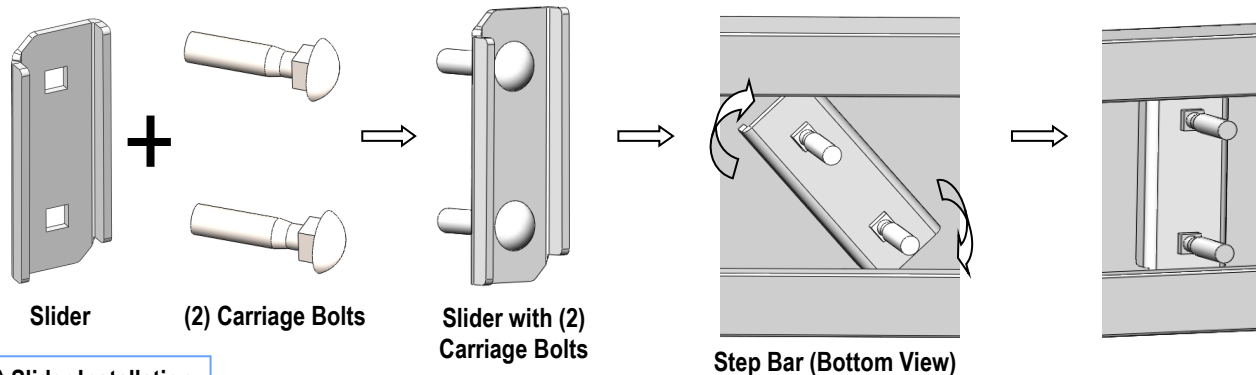

(Fig 5) Slider Installation

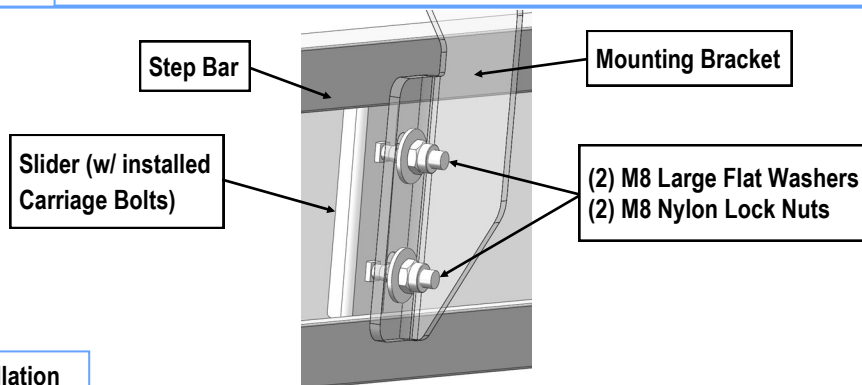

(Fig 6) Step Bar Installation