

iBoard®



Scan for
Installation Video

iBoard® by APS

PART#: IB-080C&H

READ INSTRUCTIONS CAREFULLY BEFORE STARTING INSTALLATION. REMOVE CONTENTS FROM BOX AND VERIFY ALL PARTS ARE PRESENT. ASSISTANCE IS RECOMMENDED.

*ROCKER PANEL MOUNT
*DRILLING / TRIMMING MAY BE REQUIRED

Fastener Size	Tightening Torque (ft-lbs)	Required
6mm	6-7	X
8mm	16-18	√
10mm	31-32	√
12mm	56-58	X
14mm	92-94	X

PART LIST

Driver Side Step Bar

Front

Passenger Side Step Bar

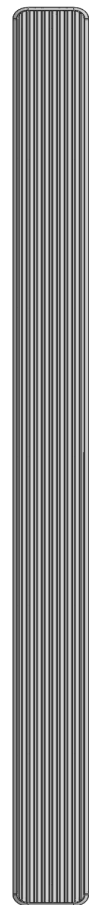
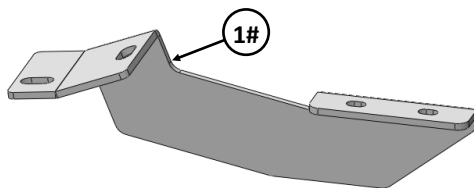
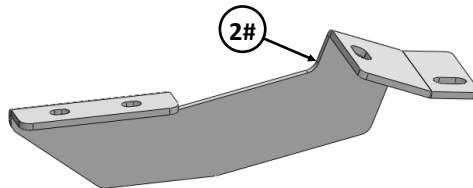
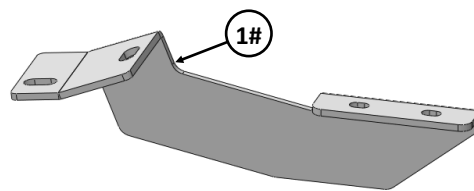
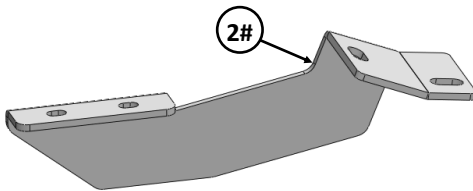
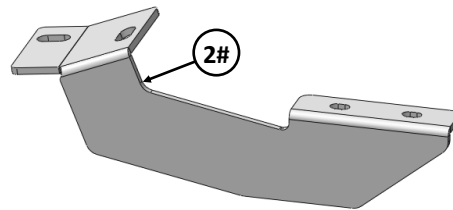
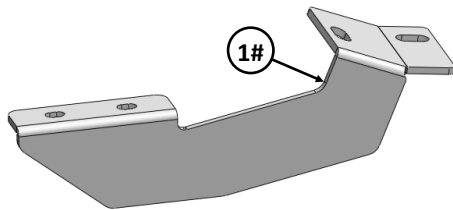
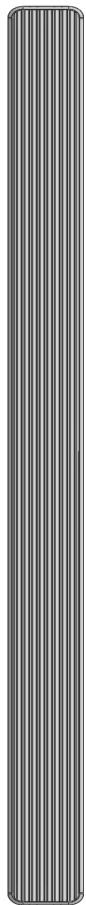



Customer Support: info@iboardauto.com





Mounting Bracket List					
Item	QTY	Description	Item	QTY	Description
1#	3	Driver Front / Passenger Center & Rear Mounting Brackets	2#	3	Passenger Front / Driver Center & Rear Mounting Brackets

Hardware Package A (For Bracket Installation)					
Item	QTY	Description	Item	QTY	Description
1#	4	85mm Tube Spacers	6#	6	M10 Flat Washers
2#	2	65mm Tube Spacers	7#	12	M10 Lock Washers
3#	4	M10X1.5-120mm Hex Bolts	8#	6	M10 Hex Nuts
4#	2	M10X1.5-110mm Hex Bolts	9#	6	M10 Clip Nuts
5#	6	M10X1.5-30mm Hex Bolts			

 1#

 3#

 4#

 5#

 6#

 2#

 7#

 8#

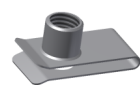
 9#

Hardware Package B (For Stainless Steel Step Bar Installation)					
Item	QTY	Description	Item	QTY	Description
1#	12	M8X1.25-35mm Carriage Bolts	3#	12	M8 Nylon Lock Nuts
2#	12	M8 Large Flat Washers	4#	6	Sliders (Packed with Step Bars)

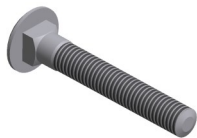
 1 #

 2 #

 3 #

 4 #



STEP 1

NOTE: On vehicles with running boards, running boards must be removed. On vehicles without running boards, remove plastic trim and mount plates fastened to bottom of rocker panel. Use 7/16" socket to remove tin nuts and screwdriver to remove plastic clips holding mount plate.

Start installation from the driver side front of the vehicle. Locate the (2) front factory holes on the driver side floor panel located by the front tire. With the threaded nut facing up, insert (1) M10 Clip Nut through larger hole. Lineup M10 Clip Nut into the smaller hole (**Fig 1**).



(Fig 1) M10 Clip Nut Installed

STEP 2

On vehicles without rear air and heat:

Select (1) Driver Front Mounting Bracket. Place (1) 65mm Tube Spacer between the Driver Front Mounting Bracket and the installed M10 Clip Nut. Insert (1) M10X1.5-110mm Hex Bolt to the installed M10 Clip Nut through tab on the Mounting Bracket and 65mm Tube Spacer (**Fig 2**). Do not fully tighten hardware at this time. Attach Driver Front Mounting Bracket to pinch weld using (1) M10X1.5-30mm Hex Bolt, (1) M10 Lock Washer, (2) M10 Flat Washers and (1) M10 Hex Nut, (**Figs 2 & 3**). Do not fully tighten hardware at this time.

NOTE: If vehicles equipped with factory step boards, the existing factory stud and nut can be used. If factory hardware is not present, use fasteners provided.

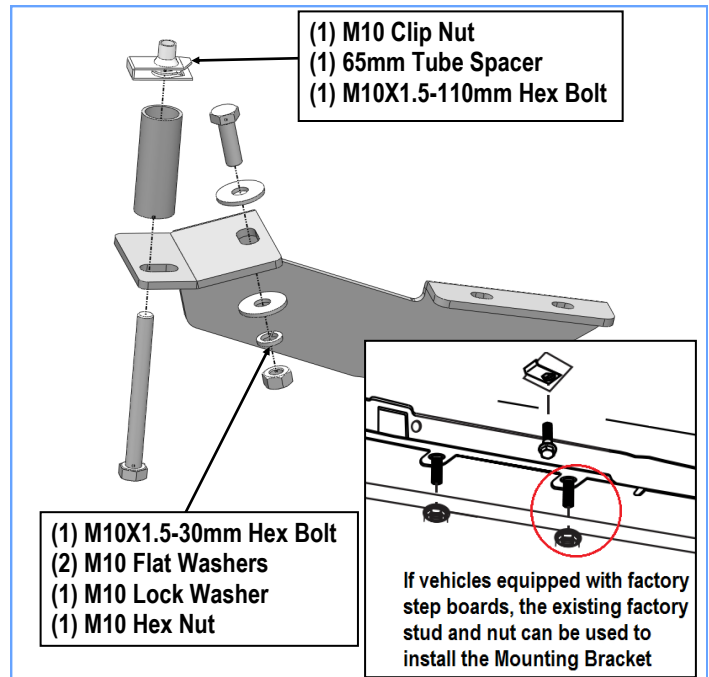

(Fig 2) Driver Side Front Mounting Bracket Installation

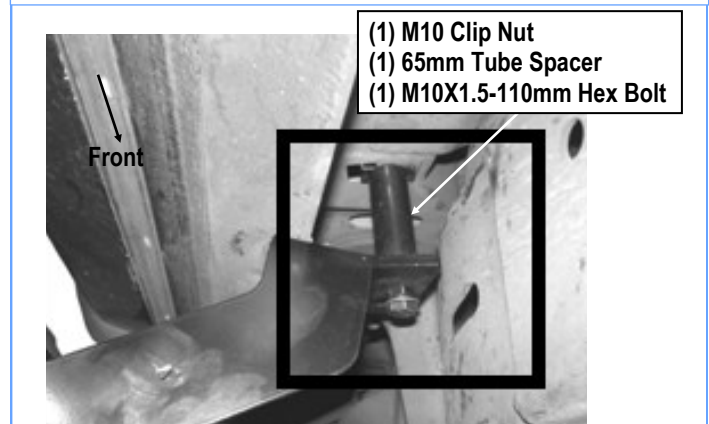

(Fig 3) Driver Side Front Mounting Bracket Installation

STEP 3

On vehicles without Factory Step boards and with rear air and heat:

The plastic studs will need to be trimmed and a 5/16" hole drilled through the plastic where the stud was. Insert bolts through these holes, (**Fig 4**).

NOTE: Be careful not to drill into the air conditioning lines.

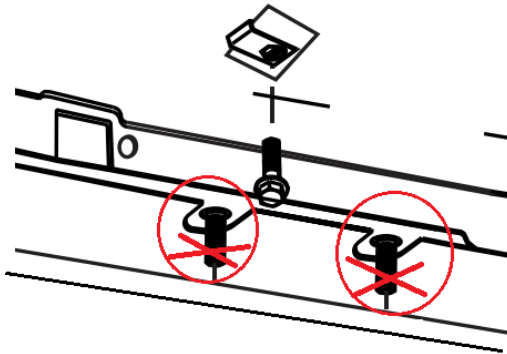

Vehicles without Factory Step boards and with rear air and heat, The plastic studs will need to be trimmed and a 5/16" hole drilled

Fig 4

Level and adjust the Step Bar and fully tighten all hardware.

Repeat **Steps 1-5** for the other side Step Bar installation. **The installation is completed!!!**

Attention

Do periodic inspections to the installation to make sure that all hardware is secure and tight.

In order to protect your bars/boards, please use mild soap/non-abrasive products for cleaning only.

STEP 4

Move to the center & rear mounting location. Repeat **Steps 1 – 4** for driver center and rear Mounting Brackets.

IMPORTANT: Depending upon your vehicle, the center factory hole might be too small for the M10 Clip Nut, file the Clip Nut until you are able to mount it. .

NOTE: 85mm Tube Spacers with M10X1.5-120mm Hex Bolts will be used on the center and rear Mounting Brackets.

STEP 5

Once all (3) Driver side mounting brackets are installed, then proceed to the Step Bar installation. (**Figs 5 & 6**)

- (1) Select (1) Slider and (2) M8X1.25-35mm Carriage Bolts;
- (2) Install (2) M8X1.25-35mm Carriage Bolts in (1) Slider.
- (3) Slide the Slider (with carriage bolts) to the **Step Bar**.
- (4) Repeat to install the other (2) sliders to the step bar.
- (5) Attach the Step Bar (with the Sliders) onto the installed mounting brackets. Position the Sliders to the installed brackets. Secure the Step Bar to the installed Brackets by using (6) M8 Large Flat Washers and (6) M8 Nylon Lock Nuts and (3) Sliders, (**Fig 6**). Do not fully tighten hardware at this time.

Note: The Sliders are packed with the Step Bars.

