

iBoard®



Scan for
Installation Video

iBoard® by APS

PART#: IB-044C&H

READ INSTRUCTIONS CAREFULLY BEFORE STARTING INSTALLATION. REMOVE CONTENTS FROM BOX AND VERIFY ALL PARTS ARE PRESENT. ASSISTANCE IS RECOMMENDED.

*ROCKER PANEL MOUNT
*NO DRILLING REQUIRED

| Fastener Size | Tightening Torque (ft-lbs) | Required |
|---------------|----------------------------|----------|
| 6mm | 6-7 | X |
| 8mm | 16-18 | √ |
| 10mm | 31-32 | X |
| 12mm | 56-58 | X |
| 14mm | 92-94 | X |

PART LIST

Driver Side Step Bar

Front
↑

Passenger Side Step Bar

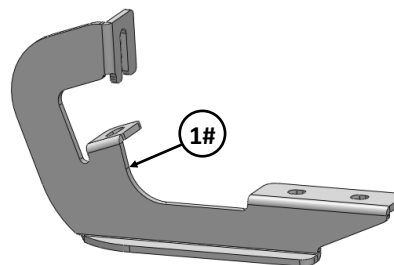
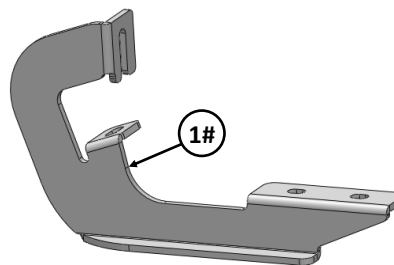
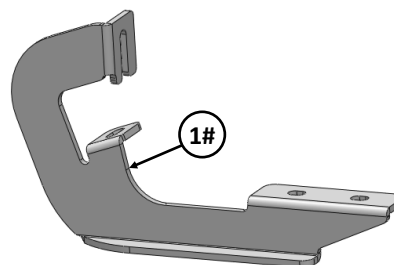
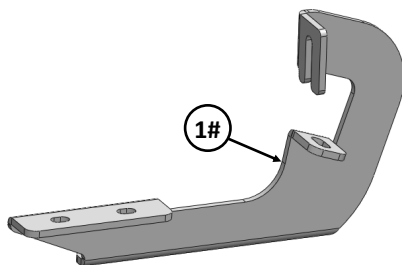
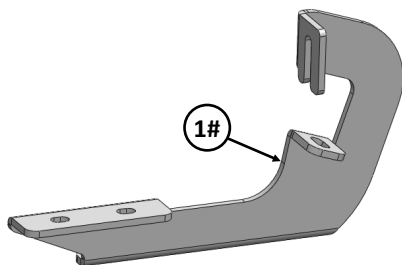
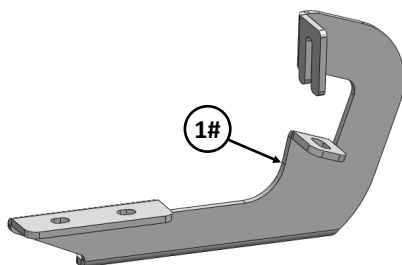



| Mounting Bracket List | | | | | |
|-----------------------|-----|-------------------|------|-----|-------------|
| Item | QTY | Description | Item | QTY | Description |
| 1# | 6 | Mounting Brackets | | | |

| Hardware Package A (For Bracket Installation) | | | | | |
|---|-----|------------------------|------|-----|------------------|
| Item | QTY | Description | Item | QTY | Description |
| 1# | 12 | M8X1.25-30mm Hex Bolts | 4# | 6 | M8X1.25 Hex Nuts |
| 2# | 18 | M8 Large Flat Washers | 5# | 6 | M8 Clip Nuts |
| 3# | 12 | M8 Lock Washers | | | |

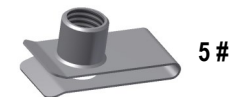

| Hardware Package B (For Stainless Steel Step Bar Installation) | | | | | |
|--|-----|-----------------------------|------|-----|---------------------------------|
| Item | QTY | Description | Item | QTY | Description |
| 1# | 12 | M8X1.25-35mm Carriage Bolts | 3# | 12 | M8 Nylon Lock Nuts |
| 2# | 12 | M8 Large Flat Washers | 4# | 6 | Sliders (Packed with Step Bars) |

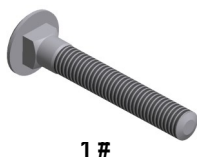



STEP 1

Starting on the driver side of the vehicle, locate the (2) holes in the bottom of the body panel, (pinch weld). Next locate the rectangular opening and (2) small holes in the inner body panel directly above the holes in the pinch weld, (**Fig 1**). Installation will use only the forward holes in each mounting location.

NOTE: The holes in the inner panel may be covered with sealing tape or insulation, remove as required.

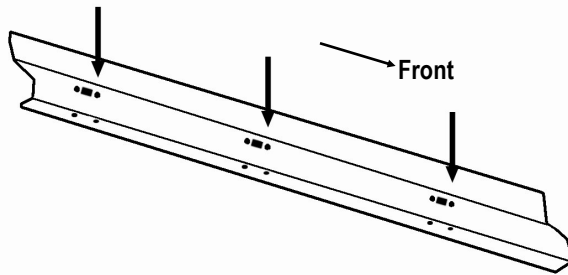

(Fig 1) Driver Side Mounting Locations

STEP 2

Slide (1) M8 Clip Nut into the rectangular opening with the nut towards the inside. Line up the threaded nut on the clip with the round hole toward the front of the vehicle, (**Fig 2**). Repeat to install an M8 Clip Nut in forward hole in the pinch weld. **NOTE:** If necessary, hold a mounting Bracket up in position to determine correct factory mounting holes location.

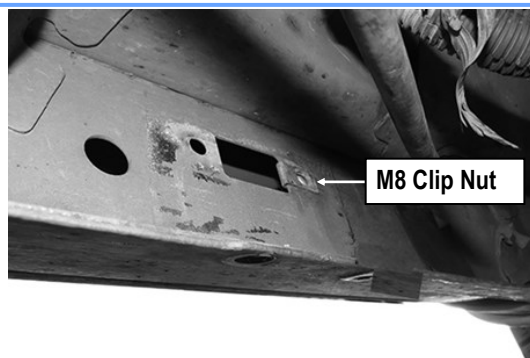

(Fig 2) Driver Front Mounting Bracket Location

STEP 3

Select the Driver Front Mounting Bracket. Attach the Bracket to the (1) M8 Clip Nut with the included (1) M8X1.25-30mm Hex Bolt, (1) M8 Lock Washer and (1) M8 Flat Washer, and to the lower hole use (1) M8X1.25-30mm Hex Bolt, (1) M8 Lock Washer, (2) M8 Large Flat Washers and (1) M8X1.25 Hex Nut (**Fig 3**). Depending on model and year, the brake cable may be run on the inside or outside of the Bracket. Do not fully tighten hardware at this time.

NOTE: The cradle on the front Bracket should face to the rear of the vehicle.

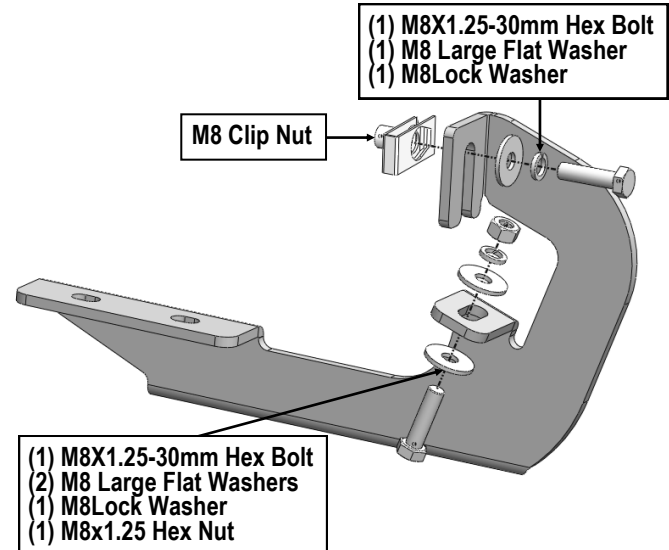

(Fig 3) Driver Front Mounting Bracket Installation

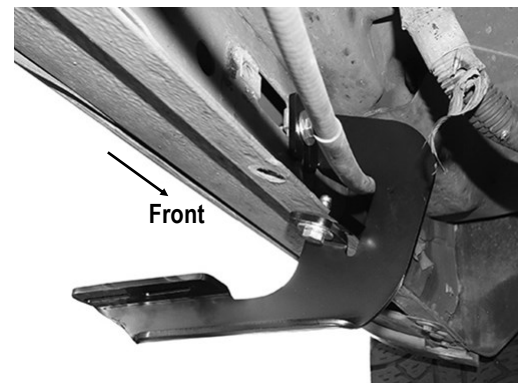

(Fig 4) Driver Front Mounting Bracket Installed



STEP 4

Next, move to the center & rear of the vehicle. Locate the (2) holes in the pinch weld similar to the front location, **(Fig 5-6)**. Repeat **Steps 1-3** to install the Driver Center Mounting Bracket & Driver Rear Mounting Bracket .

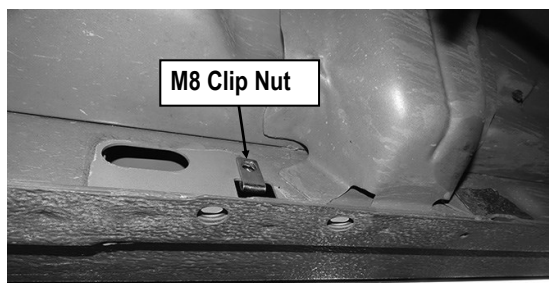

→ Front

(Fig 5) Driver Center Mounting Bracket Location

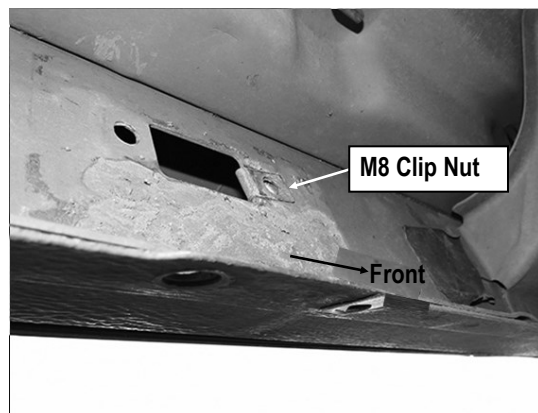

→ Front

(Fig 6) Driver Rear Mounting Bracket Location

STEP 5

Once all (3) Driver side mounting brackets are installed, then proceed to the Step Bar installation. **(Figs 7 & 8)**

- (1) Select (1) Slider and (2) M8X1.25-35mm Carriage Bolts;
- (2) Install (2) M8X1.25-35mm Carriage Bolts in (1) Slider.
- (3) Slide the Slider (with carriage bolts) to the **Step Bar**.
- (4) Repeat to install the other (2) slider to the step bar.
- (5) Attach the Step Bar (with the Sliders) onto the installed mounting brackets. Position the Sliders to the installed brackets. Secure the Step Bar to the installed Brackets by using (6) M8 Large Flat Washers and (6) M8 Nylon Lock Nuts and (3) Sliders, **(Fig 8)**. Do not fully tighten hardware at this time.

Note: The Sliders are packed with the Step Bars.

Level and adjust the Step Bar and fully tighten all hardware.

Repeat **Steps 1-5** for the other side Step Bar installation. **The installation is completed!!!**

Attention

Do periodic inspections to the installation to make sure that all hardware is secure and tight.

In order to protect your bars/boards, please use mild soap/non-abrasive products for cleaning only.



Scan for
Installation Video

