

# iBoard®

## iBoard® by APS

PART#: IB-039

READ INSTRUCTIONS CAREFULLY BEFORE STARTING INSTALLATION. REMOVE CONTENTS FROM BOX AND VERIFY ALL PARTS ARE PRESENT. ASSISTANCE IS RECOMMENDED.

\*ROCKER PANEL MOUNT  
\*NO DRILLING REQUIRED

Fastener Size	Tightening Torque (ft-lbs)	Required
6mm	6-7	√
8mm	16-18	√
10mm	31-32	√
12mm	56-58	X
14mm	92-94	X

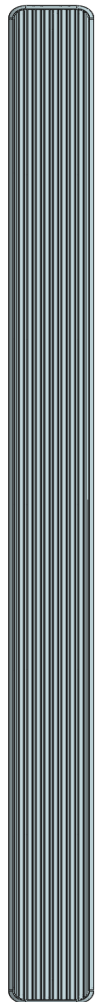

Driver Side Step Bar

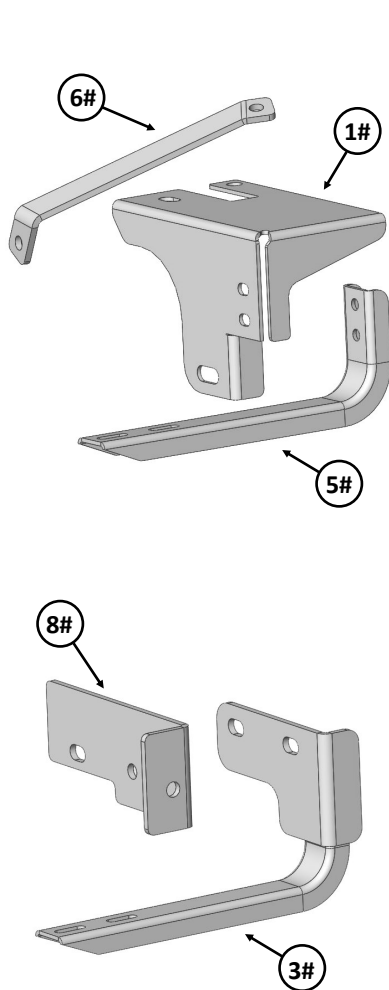

Front  
↑

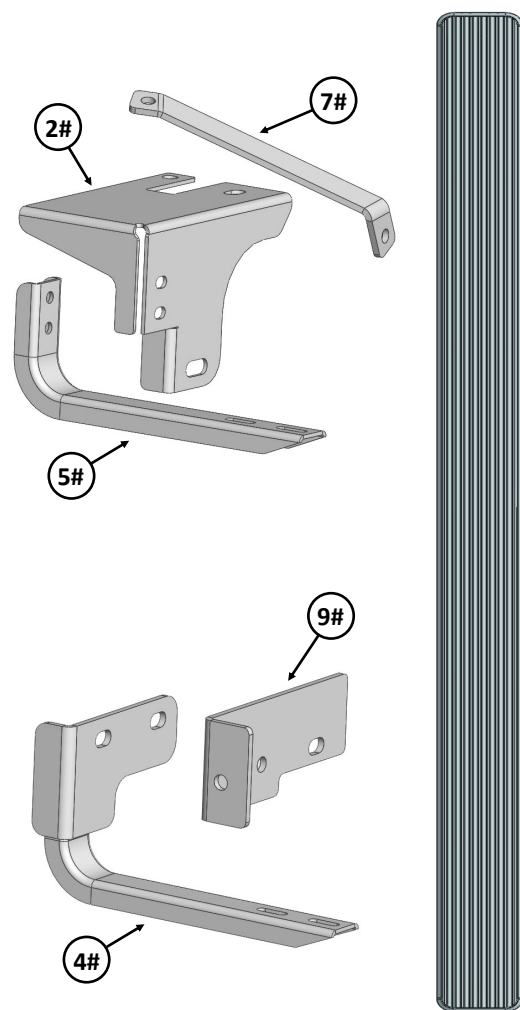

Passenger Side Step Bar

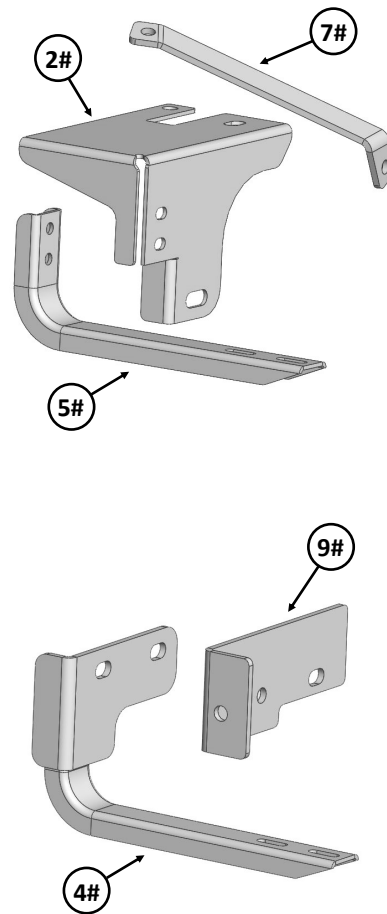

# iBoard®

Mounting Bracket List					
Item	QTY	Description	Item	QTY	Description
1#	1	Driver Front Mounting Bracket	6#	1	Driver Front Support Bracket
2#	1	Passenger Front Mounting Bracket	7#	1	Passenger Front Support Bracket
3#	1	Driver Rear Mounting Bracket	8#	1	Driver Rear Support Bracket
4#	1	Passenger Rear Mounting Bracket	9#	1	Passenger Rear Support Bracket
5#	2	Driver/Passenger Front Bar Brackets			

Hardware Package A (For Bracket Installation)					
Item	QTY	Description	Item	QTY	Description
1#	1	M10 Driver Double Nut Plate	5#	14	M10 Lock Washers
2#	1	M10 Passenger Double Nut Plate	6#	10	M10X1.5 Hex Nuts
3#	14	M10X1.5-30mm Hex Bolts	7#	4	M8X1.25-20mm Inner Hex Bolts
4#	24	M10 Flat Washers	8#	4	M8X1.25 Hex Flange Nuts

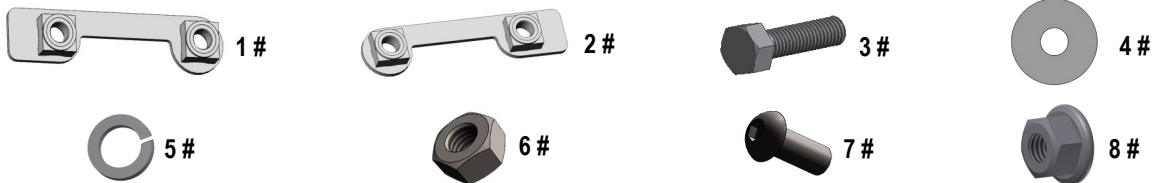

Hardware Package B (For Aluminum Step Bar Installation Only, Not Supply to SS. Step Bar)					
Item	QTY	Description	Item	QTY	Description
1#	8	M6X1-20mm Square Head Bolts	3#	8	M6X1 Nylon Lock Nuts
2#	8	M6 Large Flat Washers			



Hardware Package C (For Stainless Steel Step Bar Installation Only, Not Supply to Aluminum Step Bar)					
Item	QTY	Description	Item	QTY	Description
1#	8	M6X1-20mm Hex Bolts	3#	8	M6 Flat Washers
2#	8	M6 Lock Washers			



# iBoard®

## STEP 1

From underside of vehicle, locate the three factory holes (one large, two small) in the driver side cross frame by the front body mount. With the welded nuts facing up, insert the smaller end of the driver side Double Nut Plate through large hole in the frame and orient it to front smaller hole (**Fig 1**).

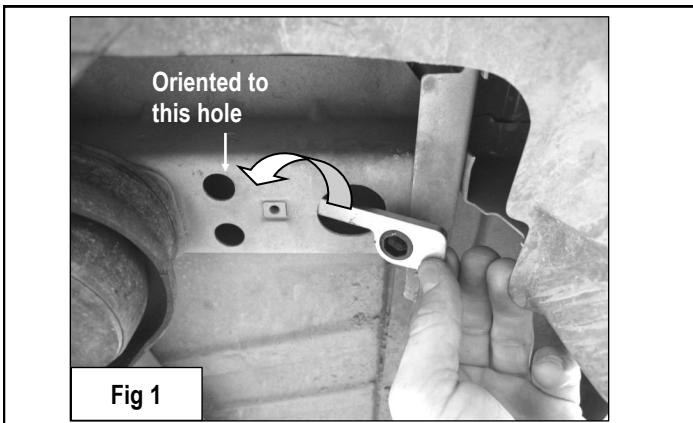

## STEP 2

Assemble Driver Front Mounting Bracket and Driver Front Bar Bracket using the included (2) M8X1.25 - 20mm Inner Hex Bolts and (2) M8X1.25 Hex Flange Nuts (**Fig 2**). Partially hang driver side front Mounting Bracket from already inserted Double Nut Plate using the included (2) M10X1.5-30mm Hex Bolts, (2) M10 Lock Washers, and (2) M10 Flat Washers (**Fig 3**). Do not fully tighten at this time.

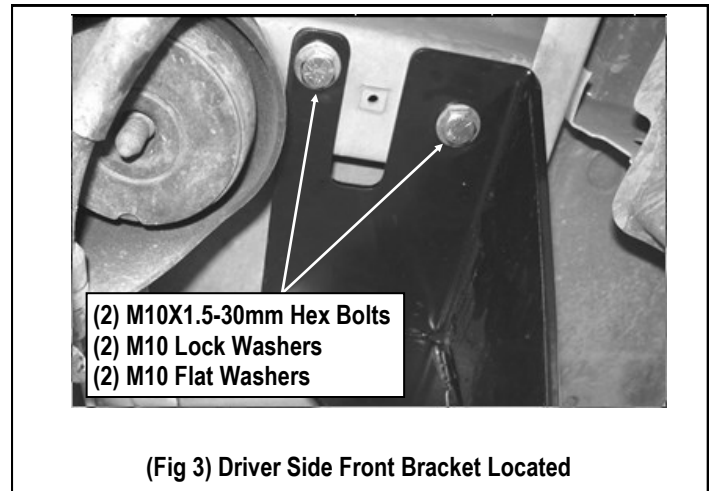
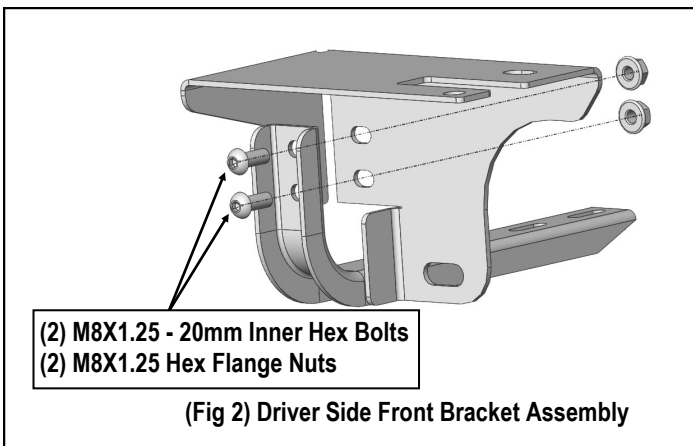

## STEP 3

On the rear side of the driver front body mount there is a factory hole in the floor panel located by the frame rail, loosely attach the straight end of the Driver Front Support Bracket to this factory hole using the included (1) M10X1.5-30mm Hex Bolt, (1) M10 Lock Washer, (1) M10X1.5 Hex Nut, and (2) M10 Flat Washers. And attach the angle end of the Driver Front Support Bracket to the Driver Front Mounting Bracket with (1) M10X1.5-30mm Hex Bolt, (1) M10 Lock Washer, (1) M10X1.5 Hex Nut, and (2) M10 Flat Washers, (**Fig 4**). Do not fully tighten at this time.

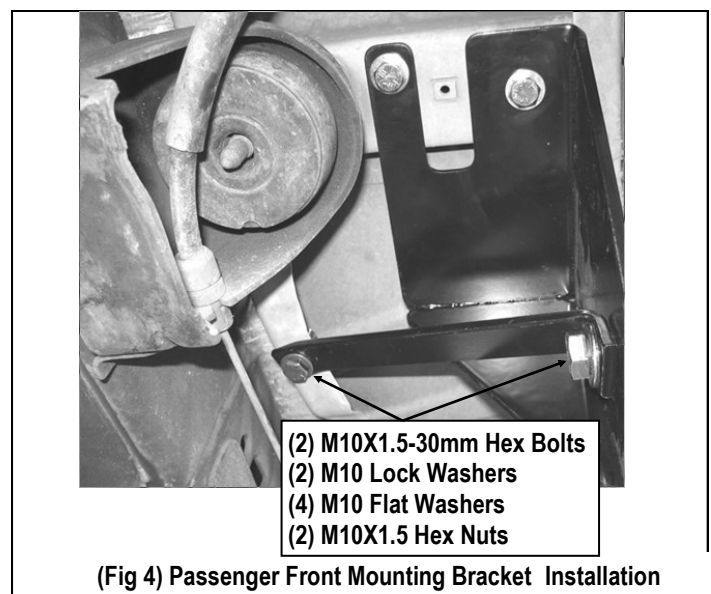

# iBoard®

## STEP 4

With the 90° bend towards the rear of the vehicle and facing the side of the vehicle, insert the Driver Rear Support Bracket (DRS) through rectangular hole located in the bottom of the body (Fig 5). Line up the hole in the 90° bend with factory hole located between the cab and the bed of the vehicle and secure it using the (1) M10X1.5-30mm Hex Bolt, (1) M10 Lock Washer, (1) M10X1.5 Hex Nut, and (2) M10 Flat Washers, (Fig 6). Do not fully tighten at this time. **NOTE:** Before tightening make sure that the two holes on the longer side of the Support Bracket lines up with the two factory holes located in the side panel.

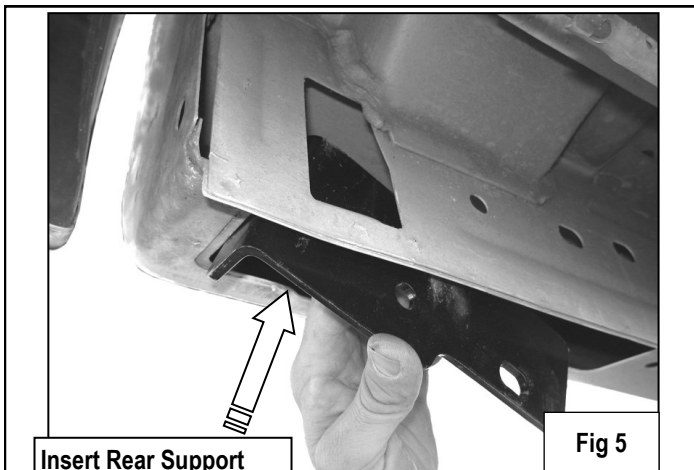

Insert Rear Support  
Bracket Through Here

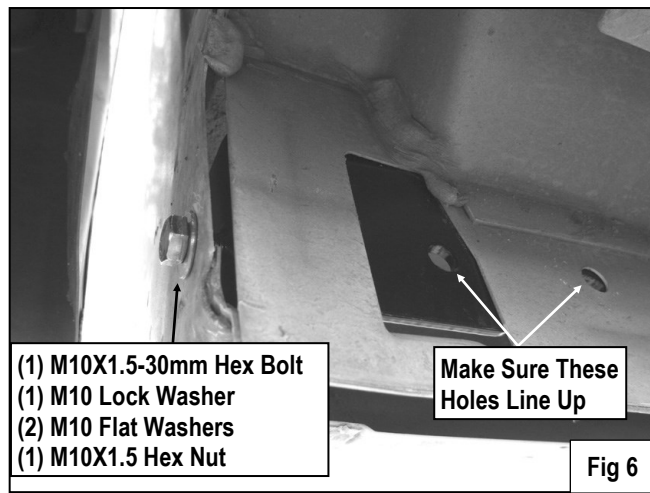

## STEP 5

Loosely attach Driver Rear Mounting Bracket to already inserted Driver Rear Support Bracket using the included (1) M10X1.5-30mm Hex Bolt, (1) M10 Lock Washer, (1) M10X1.5 Hex Nut, and (2) M10 Flat Washers, (Fig 7). Do not fully tighten at this time.

**NOTE:** Make sure that the 90° bends on the rear Mounting Bracket are facing the inside of the vehicle when installed.

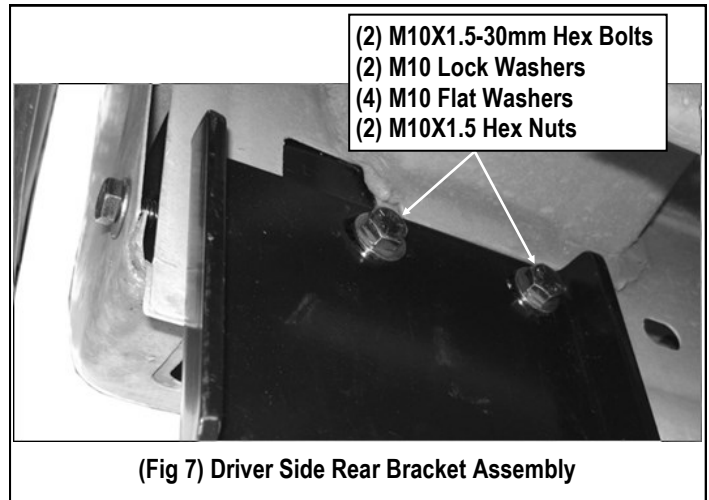

## STEP 6

Once all (2) mounting brackets are installed, then proceed to the Step Bar installation. According to the style of Step Bar proceed to the correct installation STEPS.

**Note:** Aluminum Step Bar refer to 7; Stainless Steel Step Bar skip to STEP 8.

## STEP 7

### Aluminum Step Bar Installation:

Select a **Aluminum Step Bar**. Slip (2) M6x1-20mm Square Head Bolts into each bottom channel (Fig 8). Carefully position the Step Bar onto the (2) Mounting Brackets.

# iBoard®

**IMPORTANT:** Do not slide the Step Bar on the Brackets or the bottom surface of the board will be damaged. Attach the Step Bar to each Mounting Brackets with (2) M6x1-20mm Square Head Bolts, (2) M6 Large Flat Washers and (2) M6X1 Nylon Lock Nuts, (Fig 9). Do not fully tighten at this time.

Level and adjust the Step Bar and fully tighten all hardware. Repeat **Steps 1-7** for the other side Step Bar installation. **The installation is completed!!!**



(Fig 8) Slip M6X1-20mm Square Head Bolts Into The Bottom Channels

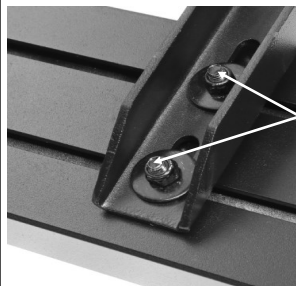

(2) M6X1-20mm Square Head Bolts  
(2) M6 Large Flat Washers  
(2) M6X1 Nylon Lock Nuts  
**IMPORTANT: TORQUE FOR 6MM FASTNERS MUST LESS THAN 6-7 FT-LBS OR THE FASTNERS WILL BE DAMAGED!**

(Fig 9) Step Bar Installed Onto Mounting Bracket

## STEP 8

### Stainless Steel Step Bar Installation:

Select a **Stainless Steel Step Bar** (with the U-Sliders installed on the Bar). Loose the U-Sliders, reposition the U-Sliders onto the board according to the (2) Installed Mounting Brackets location, (Fig 10). Re-secure the U-Sliders on the Step Bar. Attach the Step Bar to the installed Mounting Brackets with (4) M6X1-20mm Hex Bolts, (4) M6 Large Flat Washers & (4) M6 Lock Washers, (Fig 11). Do not fully tighten hardware at this time.

Level and adjust the Step Bar and fully tighten all hardware. Repeat **Steps 1-6 and 8** for the other side Step Bar installation. **The installation is completed!!!**

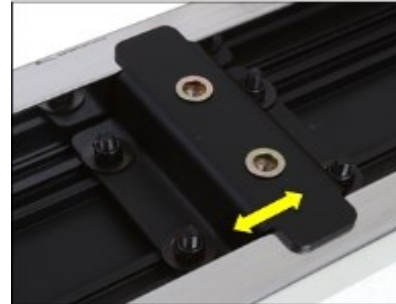

(Fig 10) Slide & line up the U-Slider with the installed mounting brackets along bottom channel

(2) M6X1-20mm Hex Bolts  
(2) M6 Large Flat Washers  
(2) M6 Lock Washers  
**IMPORTANT: TORQUE FOR 6MM FASTNERS MUST LESS THAN 6-7 FT-LBS OR THE FASTNERS WILL BE DAMAGED!**

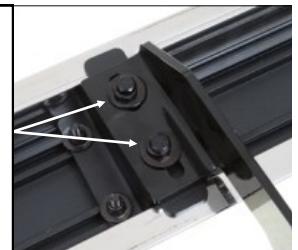

(Fig 11) Step Bar Installed on Bracket Installed (Example)

### Attention

Do periodic inspections to the installation to make sure that all hardware is secure and tight.

In order to protect your bars/boards, please use only mild soap/non-abrasive products for cleaning.