

iBoard®



Scan for
Installation Video

iBoard® by APS

PART#: IB-003S/011/003C&H

READ INSTRUCTIONS CAREFULLY BEFORE STARTING INSTALLATION. REMOVE CONTENTS FROM BOX AND VERIFY ALL PARTS ARE PRESENT. ASSISTANCE IS RECOMMENDED.

*ROCKER PANEL MOUNT
*NO DRILLING REQUIRED

Fastener Size	Tightening Torque (ft-lbs)	Required
6mm	6-7	X
8mm	16-18	√
10mm	31-32	√
12mm	56-58	X
14mm	92-94	X

PART LIST

Driver Side Step Bar

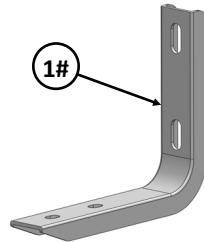
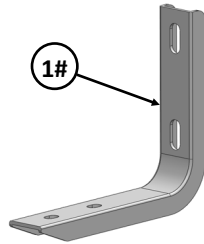
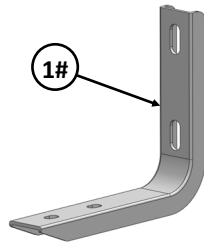
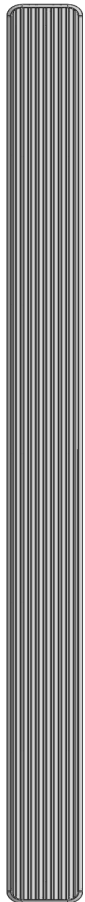

Front



Passenger Side Step Bar

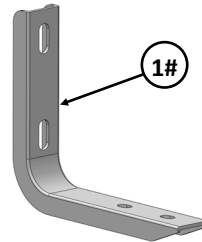
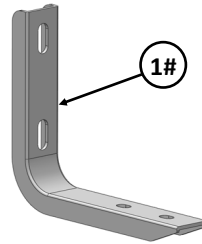
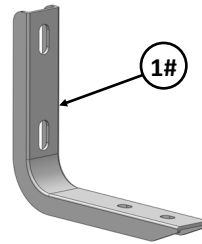

Note: (6) Mounting Brackets Are Universal.

Customer Support: info@iboardauto.com





Mounting Bracket List					
Item	QTY	Description	Item	QTY	Description
1#	6	Mounting Brackets			

Hardware Package A (For Bracket Installation)					
Item	QTY	Description	Item	QTY	Description
1#	12	M10X1.5-30mm Hex Bolts	4#	6	M10X1.5 Hex Nuts
2#	18	M10 Flat Washers	5#	6	M10 Clip Nuts
3#	12	M10 Lock Washers			

1#



2#

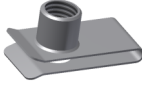

3#

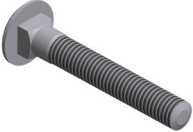

4#



5#

Hardware Package B (For Stainless Steel Step Bar Installation)					
Item	QTY	Description	Item	QTY	Description
1#	12	M8X1.25-35mm Carriage Bolts	3#	12	M8 Nylon Lock Nuts
2#	12	M8 Large Flat Washers	4#	6	Sliders (Packed with Step Bars)

1#

2#

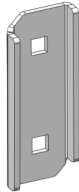

3#

4#

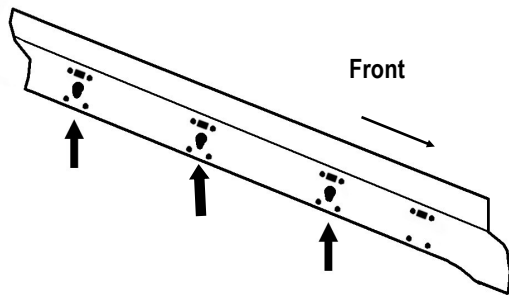

STEP 1

Starting on the driver side front of the vehicle. Locate the (3) mounting locations along the rocker panel & pinch weld. Each mounting location on the rocker panel is comprised of a rectangular hole with a round hole and (1) hole on pinch weld, (Figs 1-2).



(Fig 1) Driver Side Mounting Locations

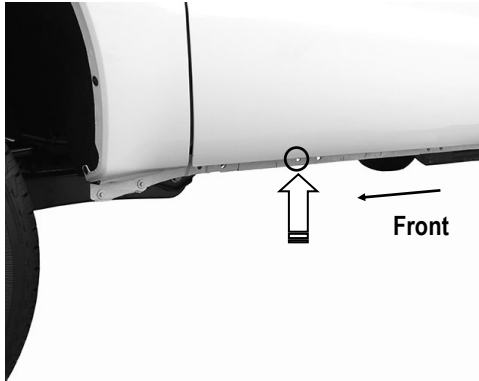

(Fig 2) The Mounting Holes on the Pinch Weld

STEP 2

Select (1) M10 Clip Nut. Insert the Clip Nut into the rectangular opening. Line up the threaded hole of Clip Nut with the round hole beside the rectangular opening, (Fig 3).

NOTE: Make sure the threaded nut on Clip Nut must toward the inner side of the rocker panel, (Fig 3).

Line Up Clip Nuts With
Factory Round Hole

Factory Hole In Pinch
Weld Pictured From
Behind Body Panel

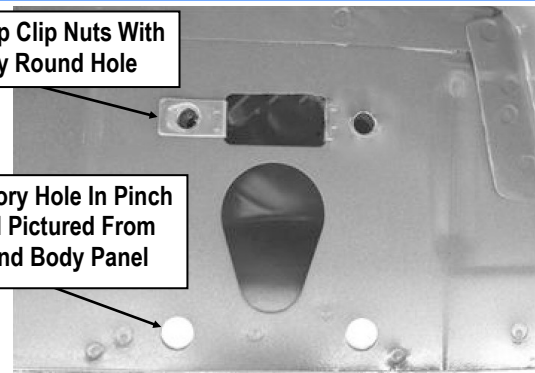

(Fig 3) M10 Clip Nut Installed

STEP 3

Partially attach the Driver Front Mounting Bracket to the M10 Clip Nut with the included (1) M10X1.5-30mm Hex Bolt, (1) M10 Lock Washer and (1) M10 Flat Washer, (Fig 4). Bolt the (1) lower hole on the Mounting Bracket to the (1) hole in the pinch weld with the included (1) M10X1.5-30mm Hex Bolt, (2) M10 Flat Washers, (1) M10 Lock Washer and (1) M10X1.5 Hex Nut, (Fig 4). Do not fully tighten hardware at this time.

(1) M10X1.5-30mm Hex Bolt
(1) M10 Flat Washer
(1) M10 Lock Washer

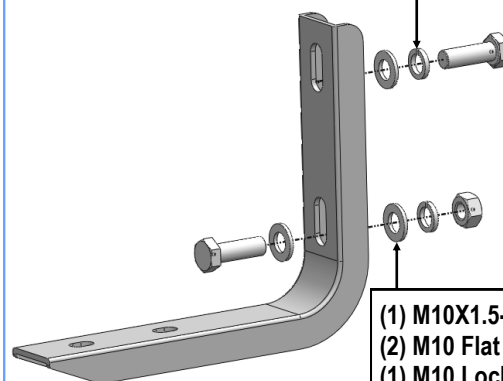

(1) M10X1.5-30mm Hex Bolt
(2) M10 Flat Washers
(1) M10 Lock Washer
(1) M10X1.5 Hex Nut

(Fig 4) Driver Front Mounting Bracket Installation



STEP 4

Move along the vehicle to the driver side center & rear mounting location. Repeat **Steps 1-3** to install the Driver Center & Rear Mounting Bracket.

Note: (6) Mounting Brackets Are Universal.

STEP 5

Once all (3) Driver side mounting brackets are installed, then proceed to the Step Bar installation. (**Figs 5 & 6**)

- (1) Select (1) Slider and (2) M8X1.25-35mm Carriage Bolts;
- (2) Install (2) M8X1.25-35mm Carriage Bolts in (1) Slider.
- (3) Slide the Slider (with carriage bolts) to the **Step Bar**.
- (4) Repeat to install the other (2) sliders to the step bar.
- (5) Attach the Step Bar (with the Sliders) onto the installed mounting brackets. Position the Sliders to the installed back-

ets. Secure the Step Bar to the installed Brackets by using (6) M8 Large Flat Washers and (6) M8 Nylon Lock Nuts and (3) Sliders, (**Fig 6**).

Do not fully tighten hardware at this time.

Note: The Sliders are packed with the Step Bars.

Level and adjust the Step Bar and fully tighten all hardware.

Repeat **Steps 1-5** for the other side Step Bar installation. **The installation is completed!!!**

Attention

Do periodic inspections to the installation to make sure that all hardware is secure and tight.

In order to protect your bars/boards, please use mild soap/non-abrasive products for cleaning only.

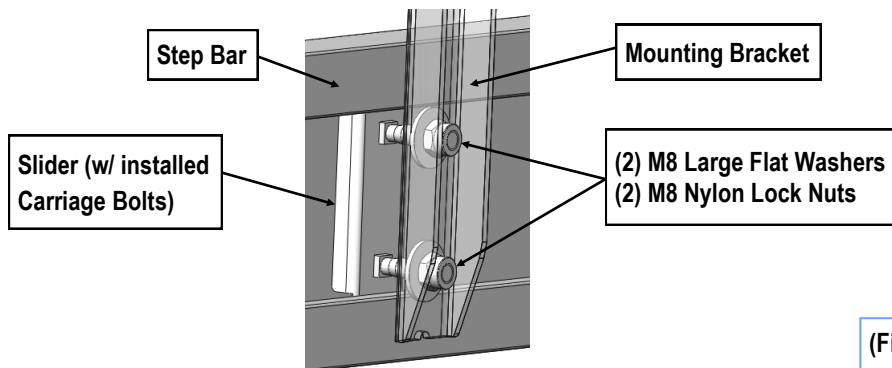
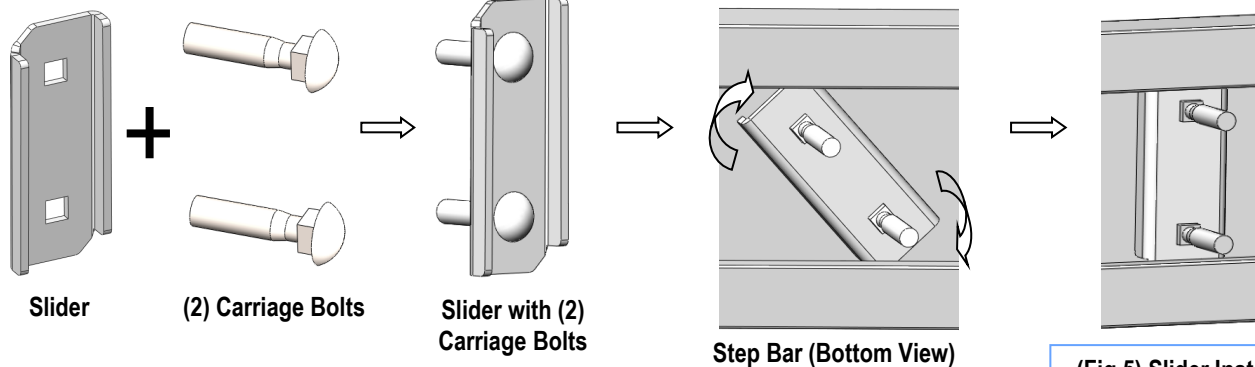

(Fig 6) Step Bar Installation