



iBoard® by APS

PART#: IB-213C&H

READ INSTRUCTIONS CAREFULLY BEFORE STARTING INSTALLATION. REMOVE CONTENTS FROM BOX AND VERIFY ALL PARTS ARE PRESENT. ASSISTANCE IS RECOMMENDED.

*ROCKER PANEL MOUNT
*DRILLING MAY BE REQUIRED

Fastener Size	Tightening Torque (ft-lbs)	Required
6mm	6-7	X
8mm	16-18	√
10mm	31-32	√
12mm	56-58	X
14mm	92-94	X

PART LIST

Driver Side Step Bar

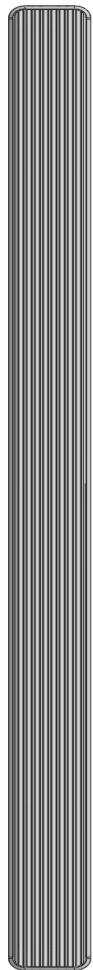

Driver Front Support Bracket (DFS)

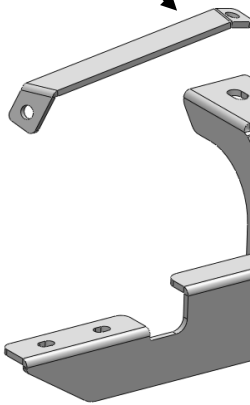

Driver Front Mounting Bracket (DFM)

Driver Rear Mounting Bracket (DRM)

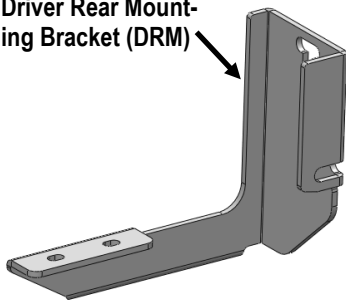

Front



Passenger Side Step Bar

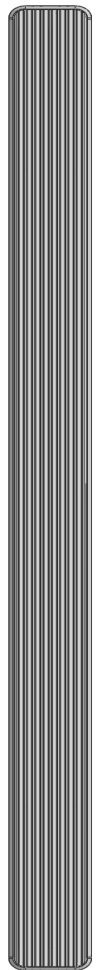

Passenger Front Support Bracket (PFS)

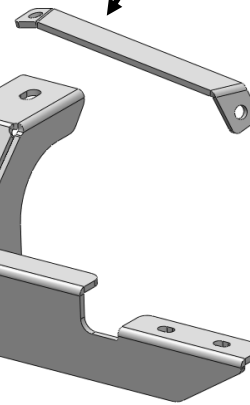

Passenger Front Mounting Bracket (PFM)

Passenger Rear Mounting Bracket (PRM)

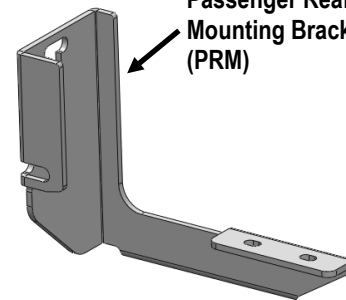



Hardware Package A (For Bracket Installation)

Item	QTY	Description	Item	QTY	Description
1#	1	M10 Driver Double Nut Plate	4#	20	M10 Large Flat Washers
2#	1	M10 Passenger Double Nut Plate	5#	12	M10 Lock Washers
3#	12	M10X1.5-30mm Hex Bolts	6#	8	M10X1.5 Hex Nuts



1#



2#

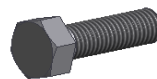

3#



4#



5#



6#

Hardware Package B (For Stainless Steel Step Bar Installation)

Item	QTY	Description	Item	QTY	Description
1#	8	M8X1.25-35mm Carriage Bolts	3#	8	M8 Nylon Lock Nuts
2#	8	M8 Large Flat Washers	4#	4	Sliders (Packed with Step Bars)

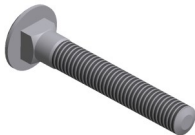

1 #



2 #



3 #

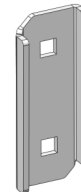

4 #



STEP 1

Start the installation under the passenger side of the vehicle. Locate the three factory holes (one large, two small) in the frame channel next to the front body mount. Insert the smaller end of the M10 Passenger Double Nut Plate through the large hole in the frame and line it up with the smaller hole, (Fig 1).

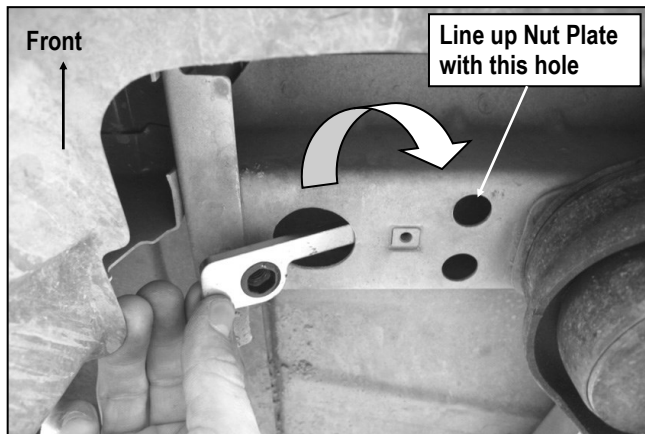

(Fig 1) Passenger Side Front Mounting Location

STEP 2

Select (1) Passenger Front Mounting Bracket, hang it to the installed M10 Double Nut Plate with the included (2) M10X1.5-30mm Hex Bolts, (2) M10 Lock Washers and (2) M10 Flat Washers, (Fig 2). Do not fully tighten hardware at this time.

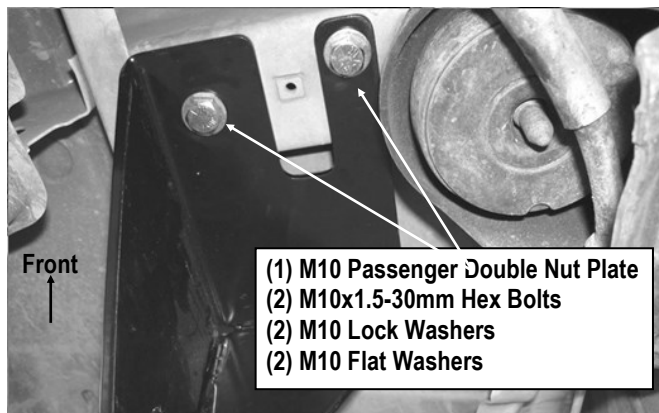

(Fig 2) Passenger Front Mounting Bracket (PFM) Installed

STEP 3

Locate the factory hole on the edge of the floor panel behind the passenger front body mount. Select the Passenger Front Support Bracket (PFS). Bolt the flat end of the Support Bracket to the factory hole using the included (1) M10 X 1.5-30mm Hex Bolt, (1) M10 Lock Washer, (2) M10 Flat Washers and (1) M10 Hex Nut, (Fig 3a).

Line up the bent end of the Support Bracket with the back of the Passenger Front Mounting Bracket. Bolt the Support Bracket using the included (1) M10 X 1.5-30mm Hex Bolt, (1) M10 Lock Washer, (2) M10 Flat Washers and (1) M10 Hex Nut, (Fig 3b). Do not fully tighten hardware at this time.

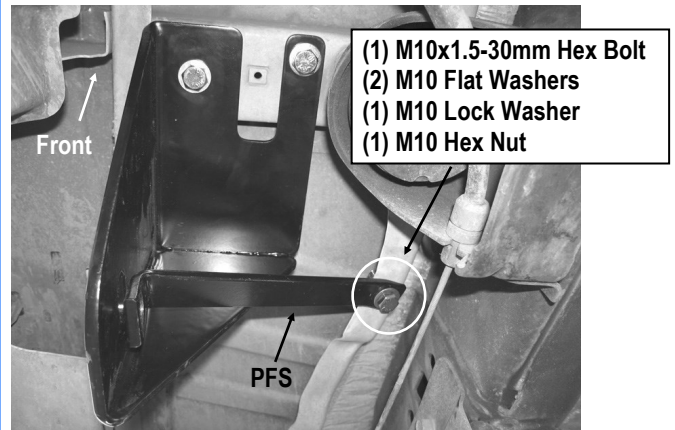

(Fig 3a) Passenger Front Support Bracket (PFS) Installation

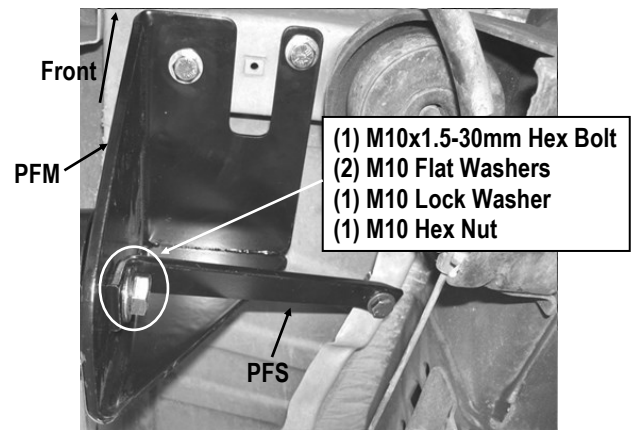

(Fig 3b) Passenger Front Support Bracket (PFS) attached to Passenger Front Mounting Bracket (PFM)



STEP 4

Insert the Passenger Rear Mounting Bracket (PRM) between the inner side panel and the outer body of the vehicle, (Fig 4 & 5). Line up the hole in the 90° bend with the factory hole in the cab toward the bed and secure it using the included (1) M10 X 1.5-30mm Hex Bolt, (1) M10 Lock Washer, (2) M10 Flat Washers and (1) M10 Hex Nut. Attach the upper mounting location in the Rear Bracket to factory hole in the inner side panel using the included (1) M10 X1.5-30mm Hex Bolt, (1) M10 Lock Washer, (2) M10 Flat Washers and (1) M10 Hex Nut, (Fig 4 & 5). Do not fully tighten hardware at this time.

NOTE: On some models, it may be necessary to drill a hole through the side panel for the hex bolts.

IMPORTANT: Any cutting or drilling tool may break or shatter. Government regulations require safety glasses & equipment at all times when cutting or drilling.



(Fig 4) Passenger Rear Mounting Bracket (PRM) Installation

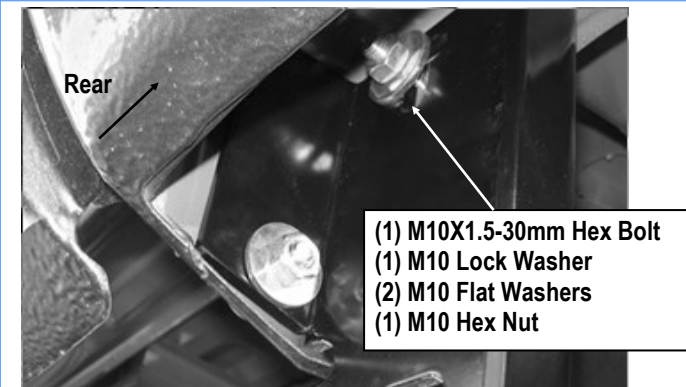

(Fig 5) Passenger Rear Mounting Bracket (PRM) Installation

STEP 5

Once all (2) Passenger side mounting brackets are installed, then proceed to the Step Bar installation. (Figs 6 & 7)

(1) Select (1) Slider and (2) M8X1.25-35mm Carriage Bolts;

(2) Install (2) M8X1.25-35mm Carriage Bolts in (1) Slider.

(3) Slide the Slider (with carriage bolts) to the **Step Bar**.

(4) Repeat to install the other (1) slider to the step bar.

(5) Attach the Step Bar (with the Sliders) onto the installed mounting brackets. Position the Sliders to the installed brackets. Secure the Step Bar to the installed Brackets by using (4) M8 Large Flat Washers and (4) M8 Nylon Lock Nuts and (2) Sliders, (Fig 7). Do not fully tighten hardware at this time.

Note: The Sliders are packed with the Step Bars.

Level and adjust the Step Bar and fully tighten all hardware.

Repeat **Steps 1-5** for the other side Step Bar installation. **The installation is completed!!!**

Attention

Do periodic inspections to the installation to make sure that all hardware is secure and tight.

In order to protect your bars/boards, please use mild soap/non-abrasive products for cleaning only.

