

iBoard®

iBoard® by APS

PART#: IB-151A-B

READ INSTRUCTIONS CAREFULLY BEFORE STARTING INSTALLATION. REMOVE CONTENTS FROM BOX AND VERIFY ALL PARTS ARE PRESENT. ASSISTANCE IS RECOMMENDED.

*BODY FRAME MOUNT
*NO DRILLING REQUIRED/ CUTTING IS REQUIRED

Fastener Size	Tightening Torque (ft-lbs)
6mm	6-7
8mm	16-18
10mm	31-32
12mm	56-58
14mm	92-94

PART LIST

Front
↑

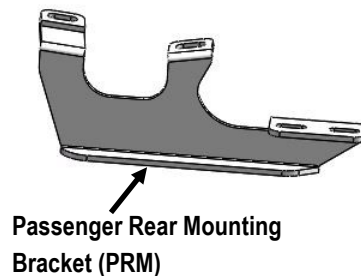
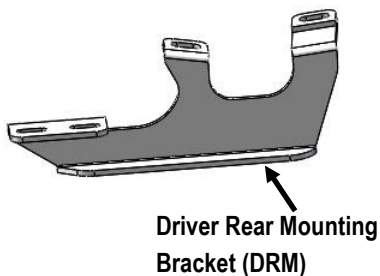
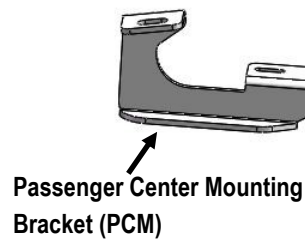
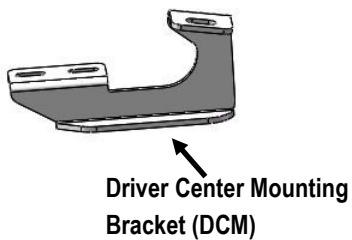
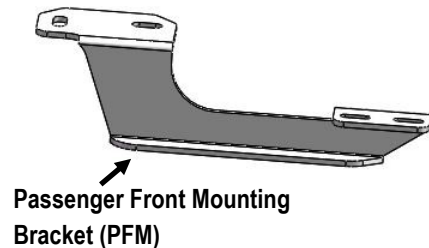
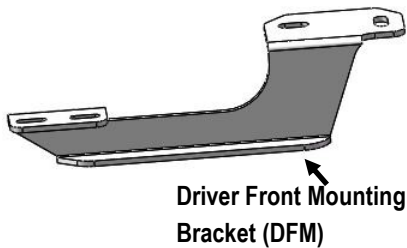

Customer Support: info@iboardauto.com

iBoard®



STEP 1

Start installation from the driver side front of the vehicle. **NOTE:** To help determine the correct mounting holes to use, hold the Front Mounting Bracket up in position against the floor panel and line up the Bracket with the correct holes, (Fig 1).

A. Driver side front Bracket installation:

Select (1) M10X35 T-Bolt Plate and (1) M10 Plastic Washer, (Fig 2A). Partially thread the M10 Plastic Washer onto the T-Bolt. Insert the T-Bolt into the inner factory oval hole. Rotate the T-Bolt 90-degrees so that the plate is across the slot. Thread the Plastic Washer down until it is tight against the floor panel. The Plastic Washer is designed to help hold the T-Bolt in place during Bracket installation, (Fig 2A & 2). Next, insert (1) M10X30 T-Bolt Plate with (1) M10 Plastic Washer into the outer oval hole in the floor panel next to the pinch weld as previously described, (Fig 2B & 2).

B. Passenger side front Bracket installation:

IMPORTANT: Repeat the previous Step 1A for passenger side Bracket installation but note that the inner mounting tab on the front Bracket will use (1) M10X35 L-Bolt Plate, (same bolt plate as used on center and rear Brackets).

Note: Inserted into a round hole instead of the M10X35 T-Bolt Plate, (Fig 2B, 4 & 5).

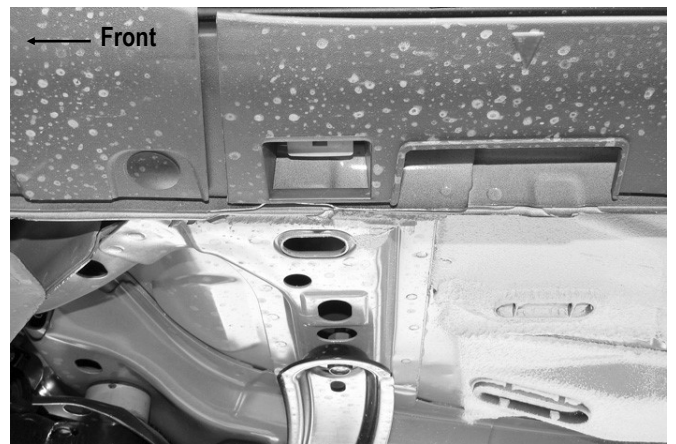

(Fig 1) Driver Side Front Mounting Location Pictured

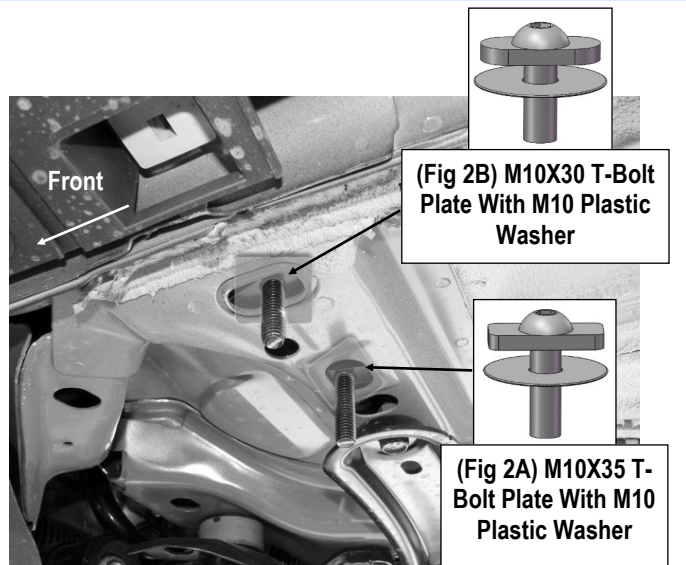

(Fig 2) Driver Side Front Mounting Location Pictured

iBoard®

STEP 3

Release the plastic clips holding the lower plastic rocker panel cover to the bottom of the body, (Fig 5).

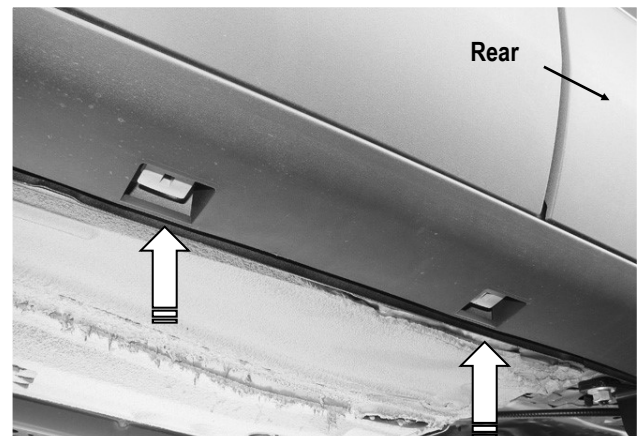

(Fig 5) Release All Clips Along Bottom Of Rocker Panel Cover

STEP 4

Measure 40" back from the bottom corner of the wheel opening to locate the correct factory hole under the plastic rocker cover for the center Bracket, (Fig 6).

Pull plastic out to access the hole, partially thread (1) M10 Plastic Washer onto (1) M10X35 L-Bolt Plate, (Fig 7 & 7A). Insert the Bolt Plate into the round hole and thread the Plastic Washer down tight against the body, (Fig 7).

NOTE: Insert the Driver Center Mounting Bracket into the approximate position.

Mark the Bracket location on the bottom edge of the plastic cover, (Fig 7). Cut a small slot in the bottom edge of the cover to clear the Bracket. Bolt the Bracket to the M10X35 L-Bolt Plate with (1) M10 Large Flat Washer, (1) M10 Lock Washer and (1) M10 Hex Nut, (Fig 8). Do not fully tighten hardware at this time.

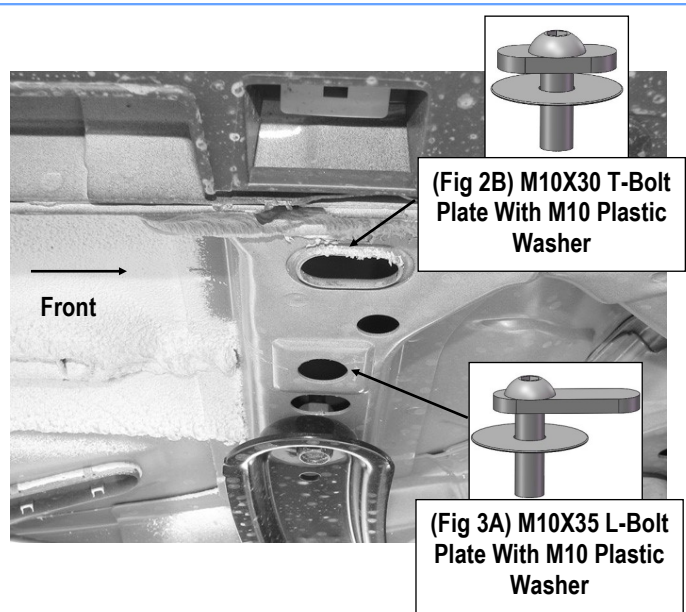

(Fig 3) Passenger Side Front Mounting Location Pictured

STEP 2

Select (1) Driver Front Mounting Bracket (DFM), attach to the T-Bolts with (2) M10 Large Flat Washers, (2) M10 Lock Washers and (2) M10 Hex Nuts, (Fig 4). Do not fully tighten hardware at this time.

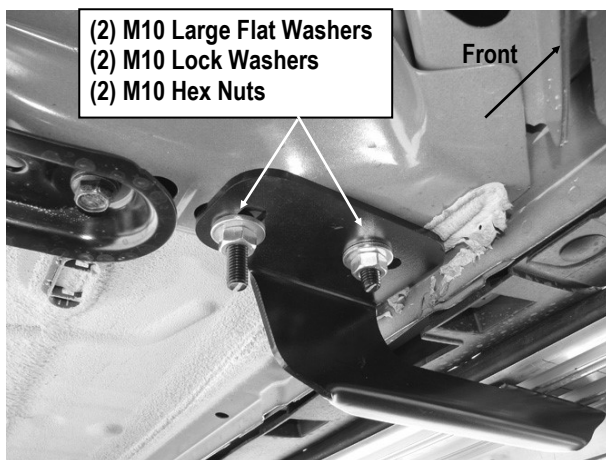

(Fig 4) Driver Side Front Mounting Bracket Installation

iBoard®

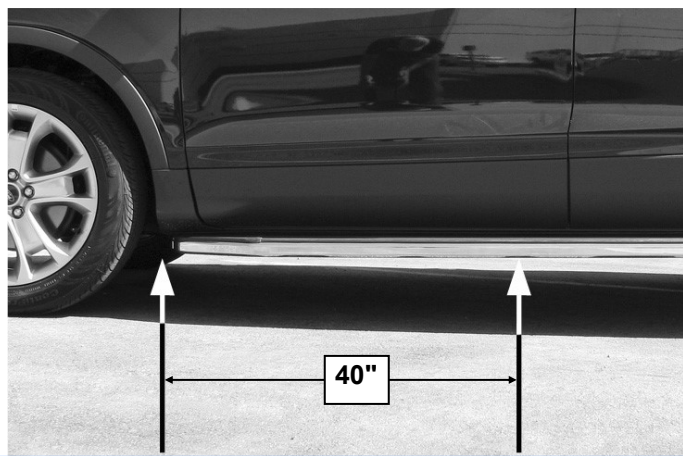

(Fig 6) Measure Approximately 40" From Bottom Corner Of Wheel Opening Along Rocker Panel To Locate Factory Hole For Center Bracket

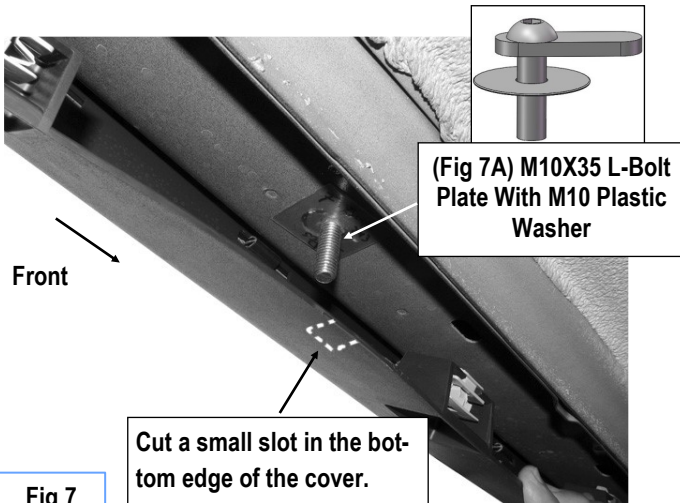
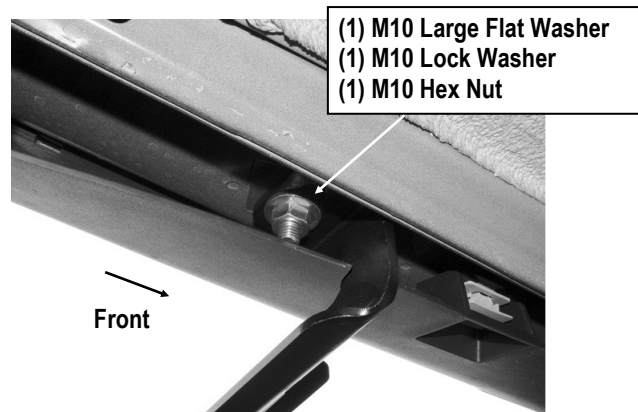

Fig 7



(Fig 8) Driver Side Center Mounting Bracket Installation

STEP 5

Move to the rear location and remove the plastic cover on the floor panel, (Fig 9). Locate the small round hole under the plastic rocker cover. Select (1) M10 Plastic Washer onto (1) M10X35 L-Bolt Plate. Insert the Bolt Plate into the round hole as described in Step 4, (Fig 10).

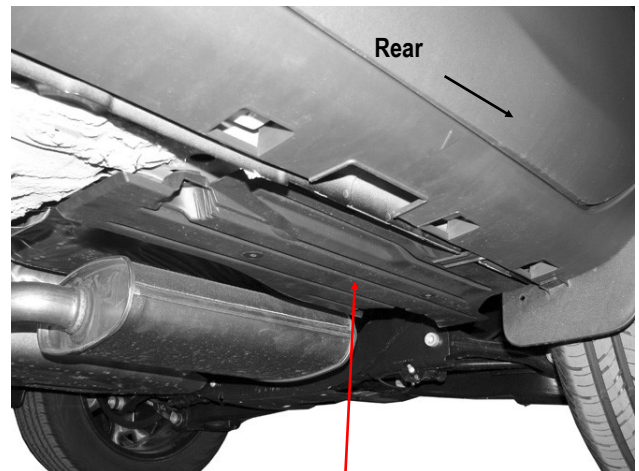

(Fig 9) Remove Plastic Cover

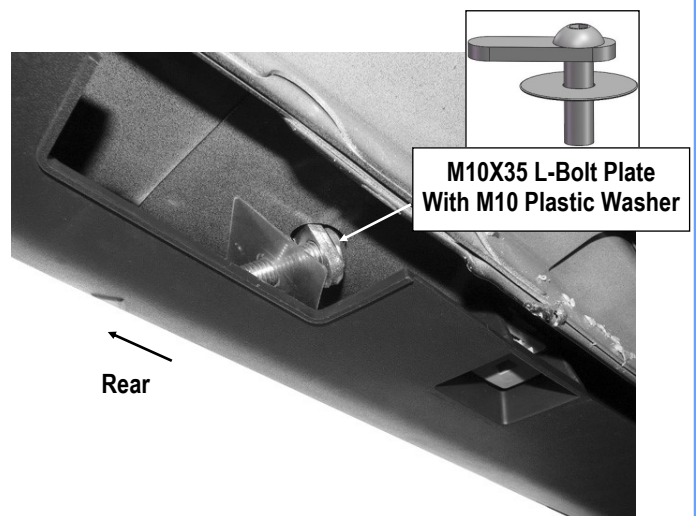

(Fig 10) Driver Side Rear Mounting Location

iBoard®

STEP 6

Next, locate the large round hole in the floor panel. Insert (1) M10X35 Bolt Plate into the large round hole and out the smaller hole toward the front, (Fig 11 & 11A).

Next, slide the Driver Rear Mounting Bracket (DRM) under the plastic rocker cover and over the (2) Bolt Plates. Secure the Bracket to the M10 Bolt Plates with (2) M10 Large Flat Washers, (2) M10 Lock Washers and (2) M10 Hex Nuts (Fig 12). Do not fully tighten hardware at this time.

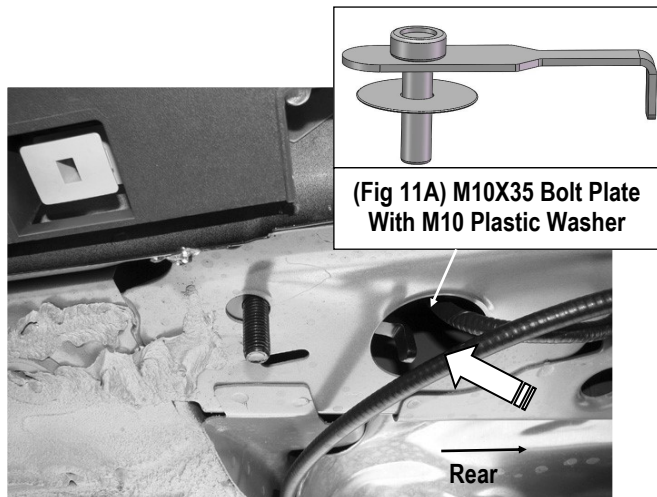

(Fig 11) Insert 10mm Bolt Plate Into Large Hole And Out Smaller Hole

(1) M10X35 Bolt Plate
(1) M10 Plastic Washer
(1) M10 Large Flat Washer
(1) M10 Lock Washer
(1) M10 Hex Nut

(1) M10X35 L-Bolt Plate
(1) M10 Plastic Washer
(1) M10 Large Flat Washer
(1) M10 Lock Washer
(1) M10 Hex Nut

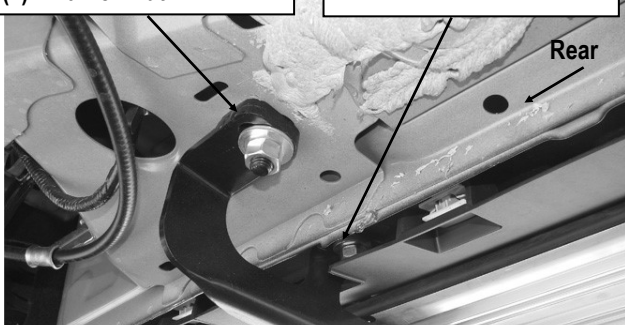

(Fig 12) Driver Rear Mounting Bracket Installation

STEP 7

Hold the plastic cover removed in Step 5, up in position. Trace the location of the Rear Bracket onto the cover, (Fig 13). Carefully cut the plastic cover to clear the Bracket, (Fig 14 & 15).

IMPORTANT: Cut as little as possible from the cover. Do not cut off the mounting area for the factory hardware. Reinstall the plastic cover and all plastic clips holding the bottom of the rocker cover to the body panel.

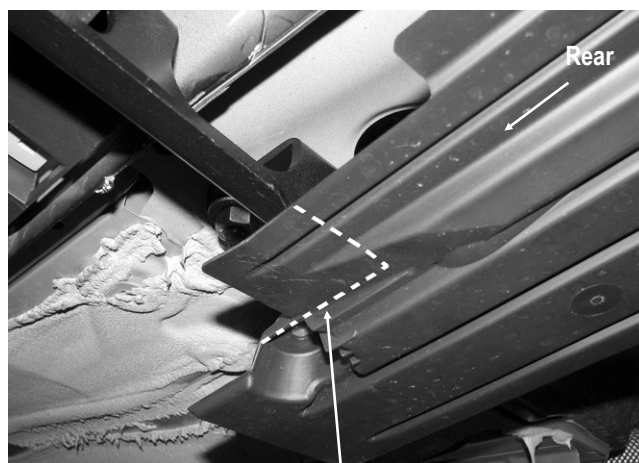

(Fig 13) Hold Plastic Cover Up In Position To Determine Area To Cut From Cover

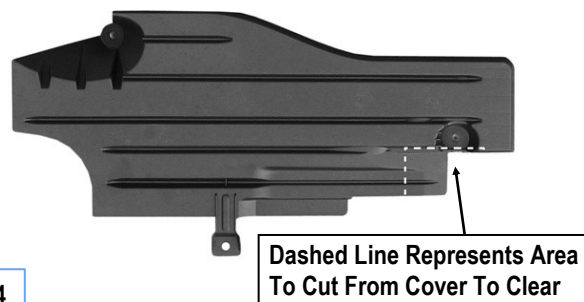

Fig 14

Dashed Line Represents Area To Cut From Cover To Clear

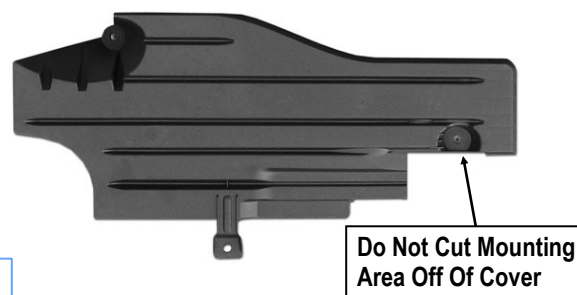

Fig 15

Do Not Cut Mounting Area Off Of Cover

iBoard®

STEP 8

Select a Running Board. Slip (2) M6X1-20mm Square Head Bolts into each bottom channel (**Fig 16**). Carefully position the Running Board onto the (3) Mounting Brackets.

Hold the Running Board up in approximate position and slide the T-Bolts down to line up with the Mounting Brackets. Tilt the Board up at a slight angle and push back against the vehicle until the T-Bolts fit into the slots on the Brackets. **VERY IMPORTANT:** The front Bracket is very close to the slots in the front-end of the Board for the T-Bolts. Loosen the Front Bracket and push it toward the rear of vehicle so that the Bracket is at a slight angle to clear the slots for the T-Bolts.

IMPORTANT: Do not slide the Running Board on the Brackets or the bottom surface of the board will be damaged. Attach the Running Board to each Mounting Bracket with (2) M6x1-20mm Square Head Bolts, (2) M6 Large Flat Washers and (2) M6 Nylon Lock Nuts (**Fig 17**). Do not fully tighten at this time.



(Fig 16) Slip M6X1-20mm Square Head Bolts Into The Bottom Channels

(2) M6X1-20mm Square Head Bolts
(2) M6 Large Flat Washers
(2) M6 Nylon Lock Nuts

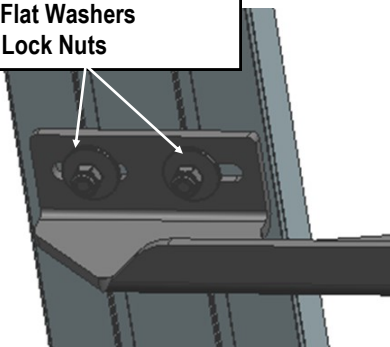

(Fig 17) Running Board Installed Onto the Mounting Bracket

STEP 9

Level and adjust the Running Board and fully tighten all hardware.

STEP 10

Repeat **Steps 1-9** for other side Running Board installation. The installation is completed.

Attention

Do periodic inspections to the installation to make sure that all hardware is secure and tight.

In order to protect your bars/boards, please use only mild soap/non-abrasive products for cleaning.