

iBoard®



Scan for
Installation Video

iBoard® by APS

PART#: IB-405C&H

READ INSTRUCTIONS CAREFULLY BEFORE STARTING INSTALLATION. REMOVE CONTENTS FROM BOX AND VERIFY ALL PARTS ARE PRESENT. ASSISTANCE IS RECOMMENDED.

*ROCKER PANEL MOUNT
*DRILLING IS REQUIRED

| Fastener Size | Tightening Torque (ft-lbs) | Required |
|---------------|----------------------------|----------|
| 6mm | 6-7 | X |
| 8mm | 16-18 | √ |
| 10mm | 31-32 | √ |
| 12mm | 56-58 | X |
| 14mm | 92-94 | X |

PART LIST

Driver Side Step Bar

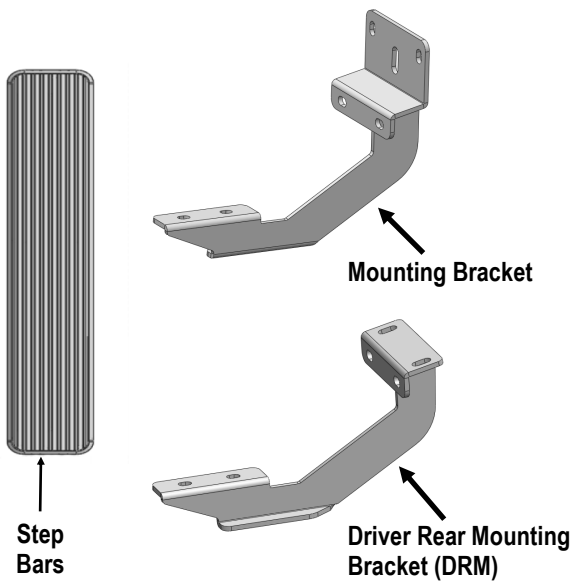

Front
↑

Passenger Side Step Bar

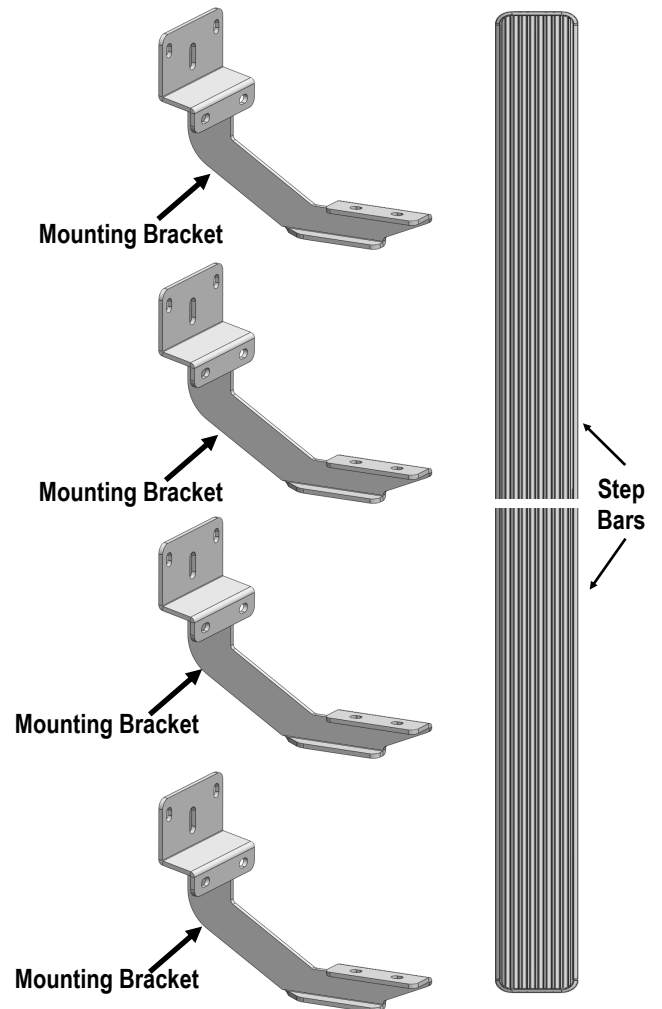

Note: Driver Front Mounting Bracket and (4) Passenger Side Mounting Brackets are universal

Customer Support: info@iboardauto.com



| Hardware Package A (For Bracket Installation) | | | | | |
|---|-----|-----------------------------|------|-----|-------------------------|
| Item | QTY | Description | Item | QTY | Description |
| 1# | 1 | M8 Insert Installation Tool | 8# | 13 | M8X1.25-25mm Hex Bolts |
| 2# | 2 | M10 Bolt Plates | 9# | 20 | M8 Large Flat Washers |
| 3# | 2 | M10 Plastic Washers | 10# | 13 | M8 Lock Washers |
| 4# | 3 | M8 U Bolts | 11# | 6 | M8X1.25 Nylon Lock Nuts |
| 5# | 4 | M10 Large Flat Washers | 12# | 1 | M8X1.25 Hex Nut |
| 6# | 2 | M10 Nylon Lock Nuts | 13# | 12 | M8 Clip Nuts |
| 7# | 1 | M8X1.25-35mm Hex Bolts | 14# | 1 | M8 Rivet Nuts |

1#

2#

3#

4#

5#

6#

7#

8#

9#

10#

11#

12#

13#

14#

| Hardware Package B (For Stainless Steel Step Bar Installation) | | | | | |
|--|-----|-----------------------------|------|-----|---------------------------------|
| Item | QTY | Description | Item | QTY | Description |
| 1# | 12 | M8X1.25-35mm Carriage Bolts | 3# | 12 | M8 Nylon Lock Nuts |
| 2# | 12 | M8 Large Flat Washers | 4# | 6 | Sliders (Packed with Step Bars) |

1 #

2 #

3 #

4 #

| Hardware Package C (For Stainless Steel Step Bar Assembly) | | | | | |
|--|-----|------------------------------|------|-----|---------------------------------------|
| Item | QTY | Description | Item | QTY | Description |
| 1# | 4 | Plastic Rivets | 5# | 2 | M8 Hex Nuts |
| 2# | 6 | M8X1.25-25mm Inner Hex Bolts | 6# | 1 | Plastic Cover (Packed with Step Bars) |
| 3# | 8 | M8 Flat Washers | 7# | 1 | Back Plate (Packed with Step Bars) |
| 4# | 6 | M8 Lock Washers | | | |

1 #

2 #

3 #

4 #

5#

6#

7#



STEP 1

Passenger Side Step Bar Assembly:

1. Select and assemble (2) Step Bars with (2) M8X1.25-25mm Inner Hex Bolts, (4) M8 Flat Washers, (2) M8 Lock Washers and (2) M8 Hex Nuts, (Fig 1). **NOTE: (2) Step Bars are universal.**
2. Attach (1) Back Plate to the bottom of the installed (2) Step Bars with (4) M8X1.25-25mm Inner Hex Bolts, (4) M8 Flat Washers, (4) M8 Lock Washers, (Fig 2).
3. Install (1) Plastic Cover to cover the joint of (2) Step bars with (4) Plastic Rivets, (Fig 3).

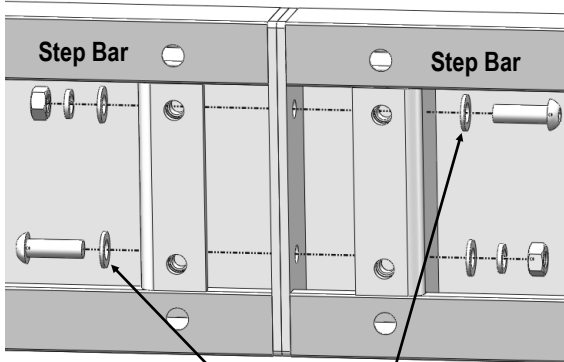

(2) M8X1.25-25mm Inner Hex Bolts
(4) M8 Flat Washers
(2) M8 Lock Washers
(2) M8 Hex Nuts

(Fig 1) Step Bars Assembly

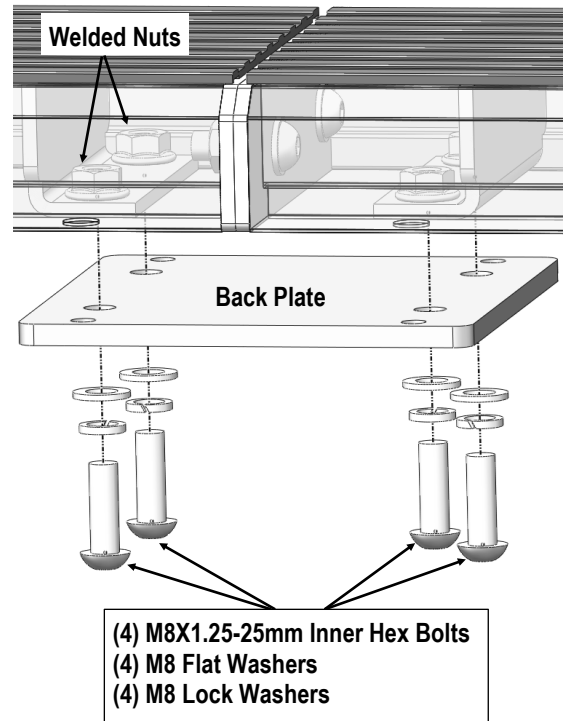

(4) M8X1.25-25mm Inner Hex Bolts
(4) M8 Flat Washers
(4) M8 Lock Washers

(Fig 2) Back Plate Installation

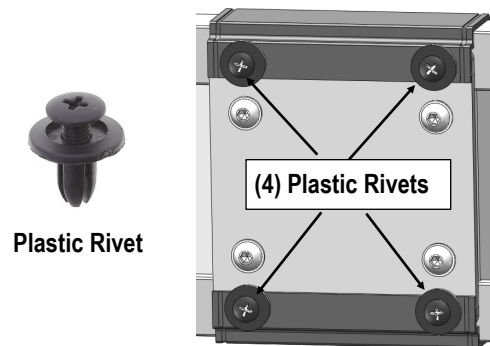

Plastic Rivet

(Fig 3) Plastic Cover Installation (Bottom View)

Assembled Passenger Side Step Bar





STEP 2

Starting installation from the passenger side front of the vehicle. Release the lower clips from the plastic trim along the bottom of the body, (Fig 4).

NOTE: From below, insert a small or medium sized flat screwdriver into the rectangular hole in the center of the clip. Carefully release each side (inside to outside, not front to back) of the plastic clip and pull the rectangular center pin down from the clip, (Fig 5). Do not twist the clip, gently pull it straight down once the clip is released. It is not necessary to completely remove the trim, only release the clips attaching the bottom of the trim to the vehicle.

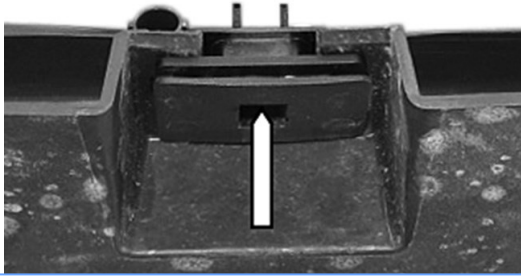

(Fig 4) Insert Flat Screwdriver Into Square Opening to Release the Plastic Clip

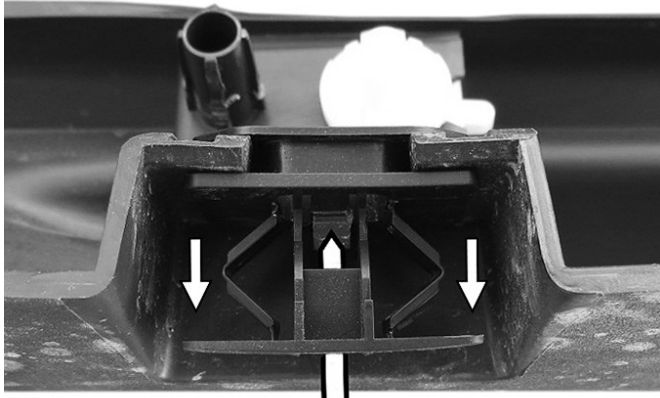

(Fig 5) Release Both Sides Of the Clip to Pull Out The Trim

STEP 3

Locate the factory hole approximately 24" back from the front of the body, (Fig 6). Remove excess undercoating from all mounting locations so that Brackets will install flat against body panel and pinch weld.

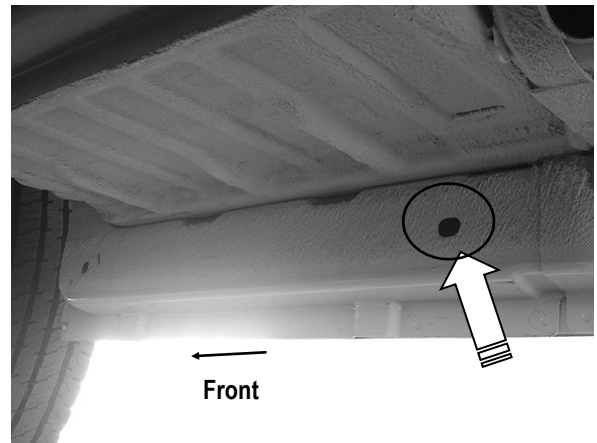

(Fig 6) Passenger Side Front Mounting Location

STEP 4

Select (1) M10 Bolt Plate, (1) M10 Flat Washer and (1) Plastic Washer. Thread the Plastic Washer onto the M10 Bolt Plate. Insert the M10 Bolt Plate into the hole and tighten the Plastic Washer against the body panel. Slide the M10 Flat Washer onto the end of the Bolt Plate, (Fig 7).

IMPORTANT: The Plastic Washer is designed to prevent the Bolt Plate from falling into the body panel within the Bracket installation.

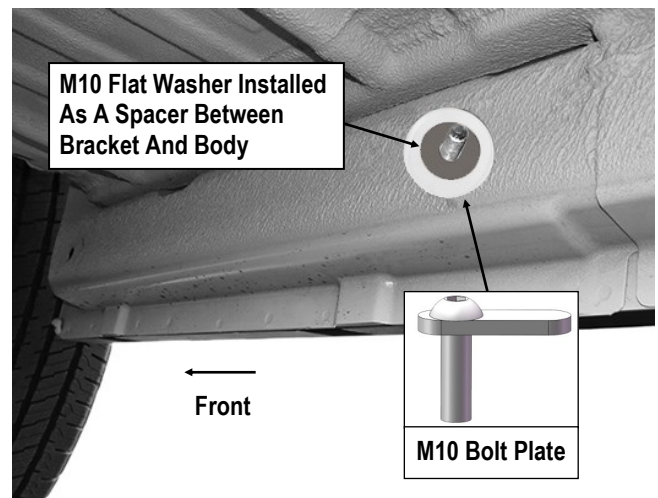

(Fig 7) M10 Bolt Plate Installed on the Passenger Side Front Mounting Location



STEP 5

Select (1) Mounting Bracket. Attach the Mounting Bracket to the installed M10 Bolt Plate with (1) M10 Flat Washer and (1) M10X1.5 Nylon Lock Nut, (Fig 8). Do not fully tighten hardware at this time.

Note: Line up the long slot in the center of the Bracket with the M10 Bolt Plate.

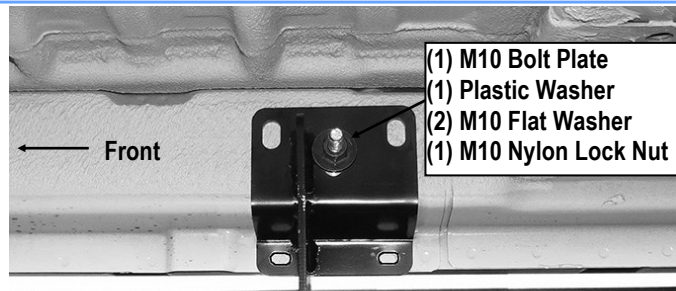

(Fig 8) Passenger Side Front Mounting Bracket Installation

STEP 6

Mark the location of the (2) bottom slots in the Bracket onto the pinch weld, (Fig 8). Remove the Bracket. Use a 3/8" drill bit to drill (2) holes through the pinch weld only, (Fig 9).

NOTE: Drill the holes as far away from the bottom edge of the pinch weld as possible.

IMPORTANT: Do not drill through the welds in the pinch weld. Slide the Bracket forward or back to move the slots away from the factory spot welds. Do not drill into or through the outer plastic rocker panel cover.

IMPORTANT!! Any cutting or drilling tool may break or shatter. Government regulations require safety glasses & equipment at all times when cutting or drilling.

STEP 7

Select (2) M8 Clip Nuts. Slide the Clip Nuts over the pinch weld with the nut toward the outside, (Fig 9). Reattach the Bracket to the Bolt Plate and pinch weld with (2) M8X1.25-25mm Hex Bolts, (2) M8 Lock Washers and (2) M8 Flat Washers, (Fig 10). Do not fully tighten hardware at this time.

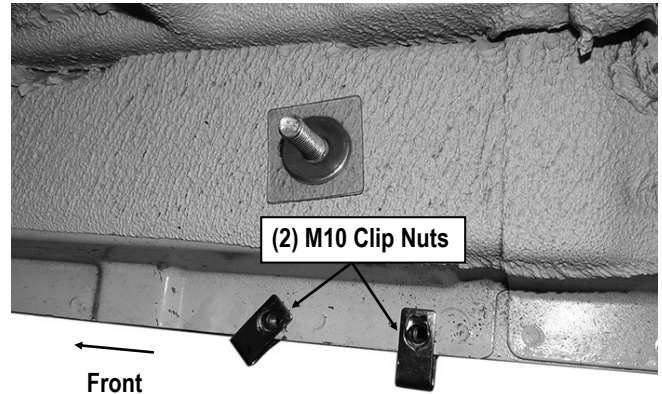

(Fig 9) Side View The Clip Nuts Over The Pinch Weld

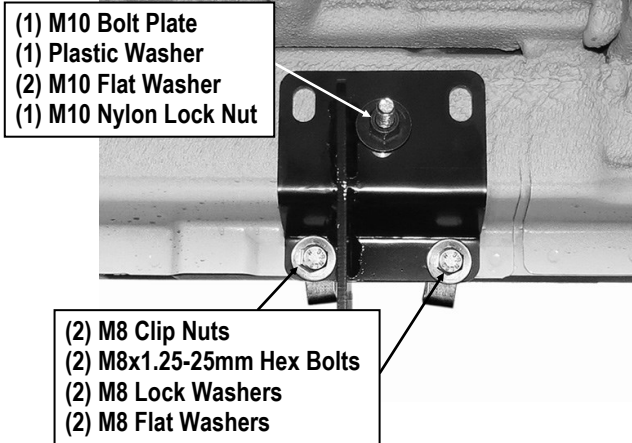

(Fig 10) Passenger Side Front Mounting Bracket Installation

STEP 8

Move along the body to the 2nd mounting location. Determine if the vehicle is equipped with factory mounting studs along the body panel.

Models without factory studs:

Locate the (2) factory holes in the side of the body panel, (Fig 11). Insert (1) M8 U Bolt into the (2) holes, (Fig 12). Select (1) Mounting Bracket, attach the Mounting Bracket to the U Bolt with (2) M8 Flat Washers and (2) M8X1.25 Nylon Lock Nuts, (Figs 13).

Repeat **Steps 6 & 7** to drill and attach the Mounting Bracket to the inner of the pinch weld, (Fig 13 & 14).

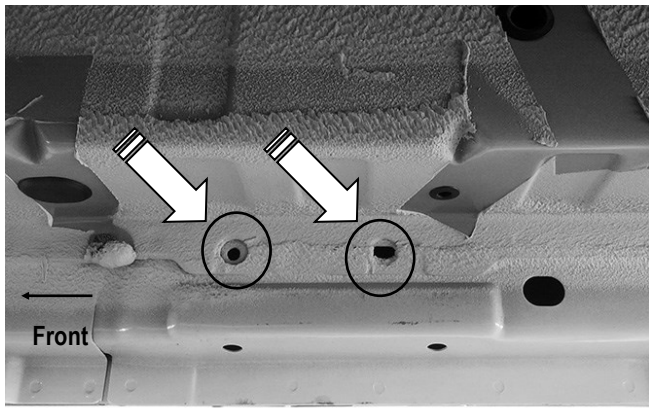

(Fig 11) Passenger Side 2nd Mounting Bracket Location

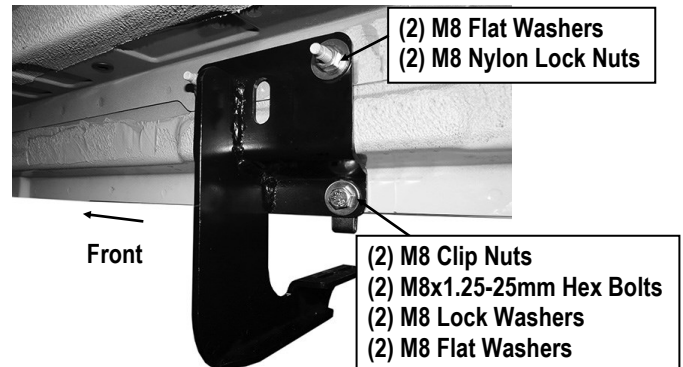

(Fig 14) Passenger Side 2nd Mounting Bracket Installation

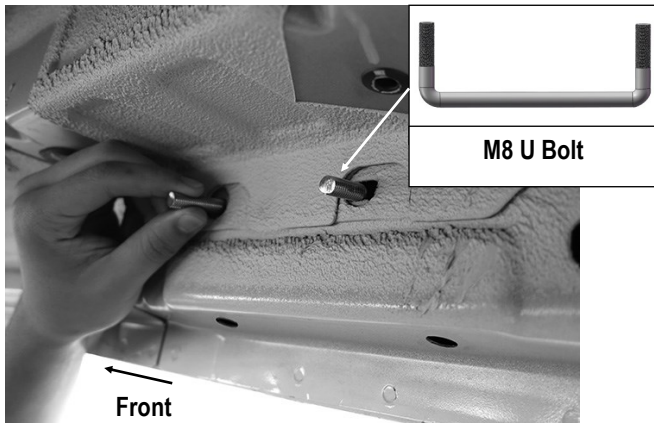

(Fig 12) Insert M8 U Bolt Into Factory Holes In Body Panel

Models with factory studs (Fig 15):

Attach (1) Mounting Bracket to the factory studs with (2) M8 Flat Washers and (2) M8x1.25 Nylon Lock Nuts.

Repeat **Steps 6 & 7**, mark and drill holes on the pinch weld, and then insert (2) M10 Clip Nuts into the drilled holes, (**Fig 15**). And reattach the Mounting Bracket to the pinch weld, (**Fig 14**).

Repeat to install (1) Mounting Bracket onto the 3rd mounting location, (**Fig 16**).

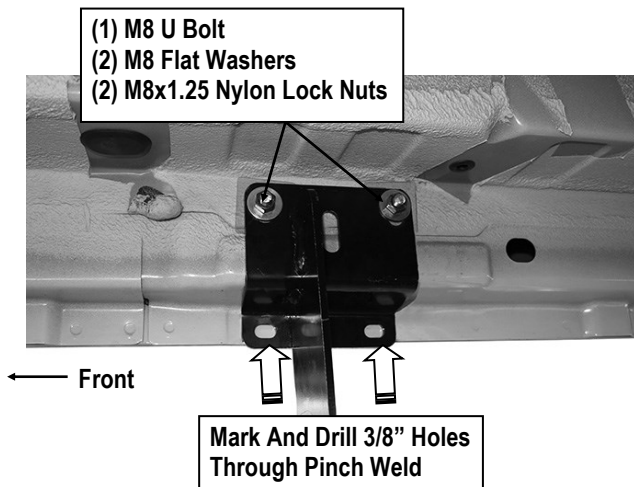

(Fig 13) Passenger Side 2nd Mounting Bracket Installation

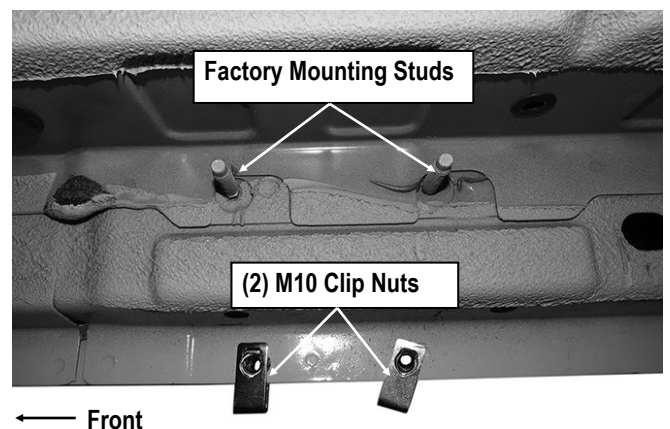

(Fig 15) Passenger Side 2nd Mounting Bracket Location

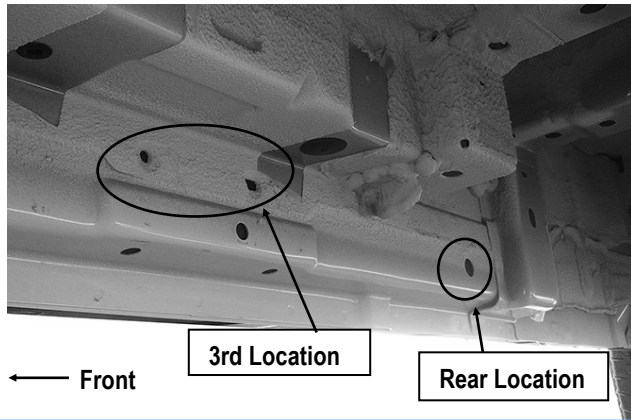

(Fig 16) Passenger Side 3rd/Rear Mounting Bracket Location

STEP 9

Move to the passenger side rear of the vehicle. Repeat **Steps 3—7** to install (1) Mounting Bracket in the passenger side rear mounting location.

STEP 10

Once all (4) Passenger side mounting brackets are installed, then proceed to the Step Bar installation. (**Figs 17 & 18**)

- (1) Select (1) Slider and (2) M8X1.25-35mm Carriage Bolts;
- (2) Install (2) M8X1.25-35mm Carriage Bolts in (1) Slider.
- (3) Slide the Slider (with carriage bolts) to the **Step Bar**.
- (4) Repeat to install the other (3) sliders to the step bar.
- (5) Attach the Step Bar (with the Sliders) onto the installed mounting brackets. Position the Sliders to the installed brackets. Secure the Step Bar to the installed Brackets by using (8) M8 Large Flat Washers and (8) M8 Nylon Lock Nuts and (4) Sliders, (**Fig 18**). Do not fully tighten hardware at this time.

Note: The Sliders are packed with the Step Bars.

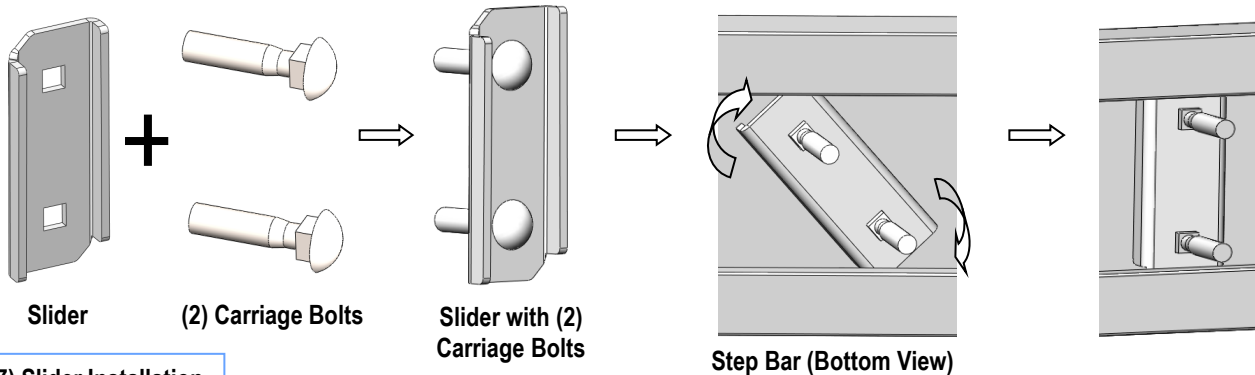

(Fig 17) Slider Installation

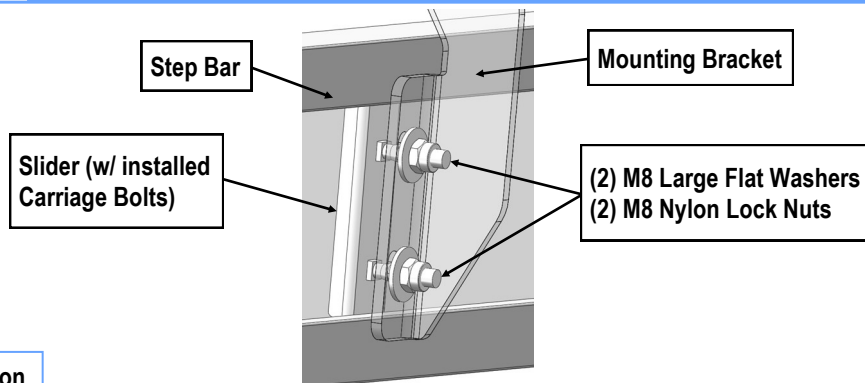

(Fig 18) Step Bar Installation



STEP 11

Level and adjust the Step Bar and fully tighten all hardware.
Reinstall the plastic trim along the bottom of the body.

IMPORTANT: Minor trimming may be required around M8 Clip Nuts. Temporarily remove the Step Bar. Use a sharp knife or hacksaw blade to trim plastic as required.

STEP 12

Move to the driver side front of the vehicle. Repeat **Step 2, (Fig 4 & 5)**, to release the clips attaching the plastic trim to the bottom of the driver side. Identify the front bracket mounting location approximately 10" away from the front edge of the body panel, (**Fig 19**).

Select (1) Mounting Bracket. Hold the Mounting Bracket firmly in position against the body panel and pinch weld. Mark the upper left hole location onto the inner body panel. Also mark the (2) lower mounting locations onto the pinch weld and the drill holes according to the marks, (**Fig 19**).

IMPORTANT: Do not drill through the welds in the pinch weld. Slide the Bracket forward or back to move the slots away from the factory spot welds. Do not drill into or through the outer plastic rocker panel cover.

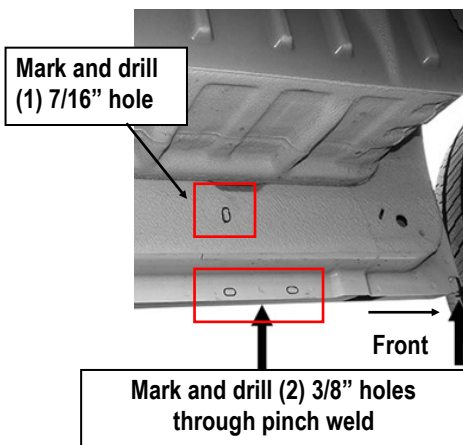

(Fig 19) Driver Side Front Mounting Bracket Location

STEP 13

Select (1) M8 Rivet Nut, (1) M8X1.25-35mm Hex Bolt, (1) M8 Hex Nut, (1) M8 Flat Washer and (1) M8 Insert Tool. Thread the M8 Hex Nut onto the M8 Hex Bolt. Assemble the M8 Insert Tool as pictured in **Fig 20**.

NOTE: Select 8mm hole on M8 Insert Tool (**Fig 21**). Use a 13mm wrench to hold the M8 Hex Bolt to prevent it from spinning. Turn the M8 Hex Nut counter-clockwise to pull/expand the insert in the hole, (**Fig 22**). Tighten the M8 Hex Nut until the Insert is fully installed, (**Figs 20 & 23**). Do not over tighten the M8 Hex Nut.

Bolt the Mounting Bracket to the M8 Rivet Nut with (1) M8x1-25mm Hex Bolt, (1) M8 Lock Washer and (1) M8 Flat Washer, (**Fig 23**).

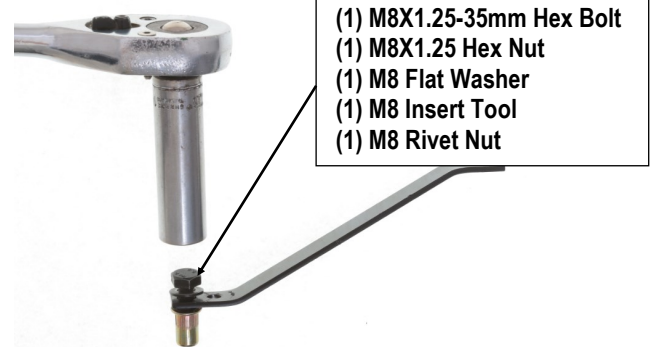

(Fig 20) M8 Insert Tool Assembly

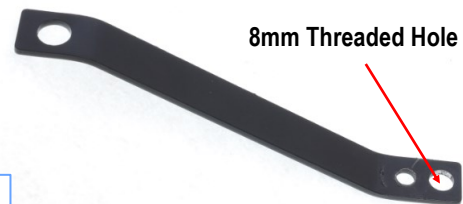

Fig 21

Hold M8 Hex Bolt in position with wrench.
Turn M8 Hex Nut clockwise to "pull" insert



(Fig 22) M8 Insert Tool Assembly



STEP 14

Insert (2) M8 Clip Nuts into the drilled holes on pinch weld, (Fig 23). Attach Mounting Bracket to the installed M8 Rivet Nut on body panel, (Fig 24). Secure the lower mounting holes to the installed (2) M8 Clip Nuts on pinch weld with (2) M8X1.25-25mm Hex Bolts, (2) M8 Lock Washers and (2) M8 Flat Washers, (Fig 24). Do not fully tighten hardware at this time.

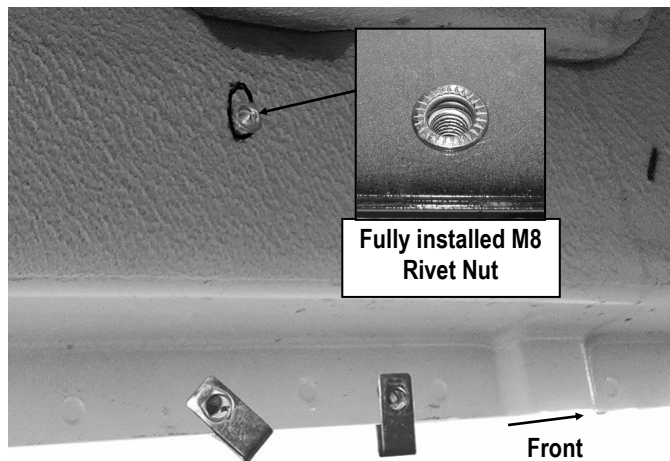

(Fig 23) Driver Side Front Mounting Location

- (1) M8x1.25-25mm Hex Bolt
- (1) M8 Lock Washer
- (1) M8 Flat Washer

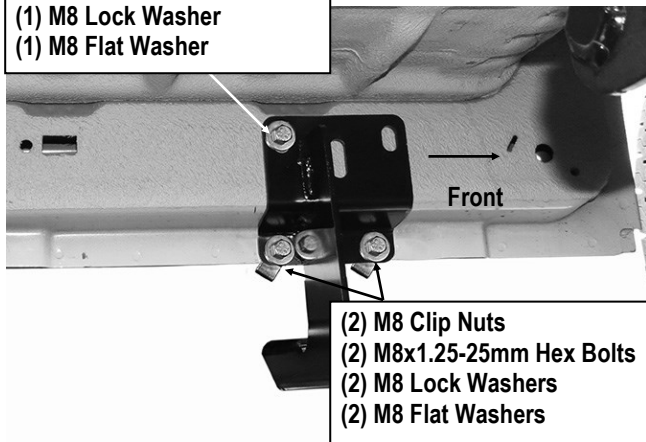

(Fig 24) Driver Front Mounting Bracket Installed

STEP 15

Move to the driver side rear mounting location (approximately 24" away from the front edge of the body panel), (Fig 25).

Select the Driver Rear Mounting Bracket (DRM). Hold the Bracket firmly against the bottom of the body panel and pinch weld. Mark and drill holes as shown on Fig 25.

NOTE: Slide the Bracket forward as necessary to avoid drilling through any factory welds on the pinch weld.

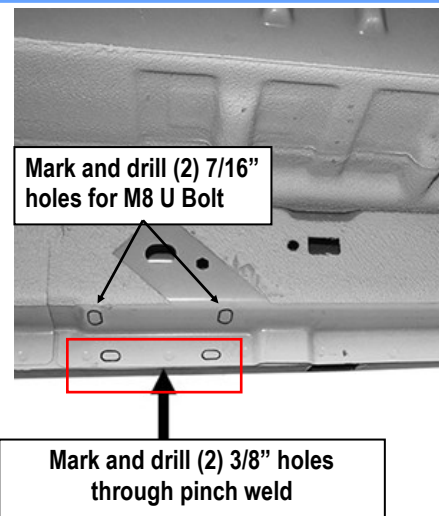

(Fig 25) Driver Side Rear Mounting Location

STEP 16

Insert (1) M8 U Bolt into the (2) drilled 7/16" holes. And insert (2) M8 Clip Nuts into the (2) drilled 3/8" holes on pinch weld.

Select (1) Driver Rear Mounting Bracket (DRM). Attach the upper slots on the Bracket to the installed M8 U Bolt with (2) M8 Flat Washers and (2) M8X1.25 Nylon Lock Nuts. Secure the lower holes of the mounting bracket to the installed (2) M8 Clip Nuts on pinch weld with (2) M8X1.25-25mm Hex Bolts, (2) M8 Lock Washers, (2) M8 Flat Washers (Fig 26). Do not fully tighten hardware at this time.

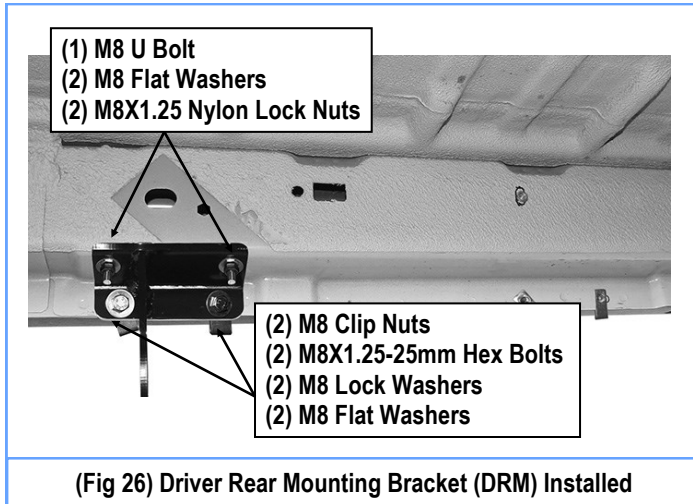

STEP 18

Level and adjust the Step Bar and fully tighten all hardware.

Reinstall the plastic trim along the bottom of the body.

IMPORTANT: Minor trimming may be required around M8 Clip Nuts. Temporarily remove the Step Bar. Use a sharp knife or hacksaw blade to trim plastic as required.

The installation is completed.

Attention

Do periodic inspections to the installation to make sure that all hardware is secure and tight.

In order to protect your bars/boards, please use mild soap/non-abrasive products for cleaning only.

STEP 17

Select the driver side Step Bar. Repeat **Step 10** to attach the Step Bar to the (2) Brackets.