

iBoard®

iBoard® by APS

PART#: IB-405A-B

READ INSTRUCTIONS CAREFULLY BEFORE STARTING INSTALLATION. REMOVE CONTENTS FROM BOX AND VERIFY ALL PARTS ARE PRESENT. ASSISTANCE IS RECOMMENDED.

***ROCKER PANEL MOUNT
*DRILLING IS REQUIRED**

Fastener Size	Tightening Torque (ft-lbs)
6mm	6-7
8mm	16-18
10mm	31-32
12mm	56-58
14mm	92-94

PART LIST

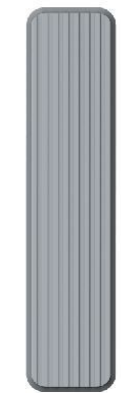

Driver Side

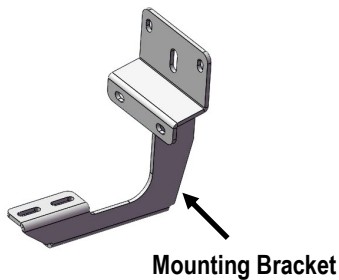

Mounting Bracket

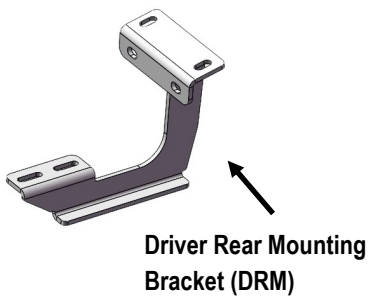

Driver Rear Mounting Bracket (DRM)

Front
↑

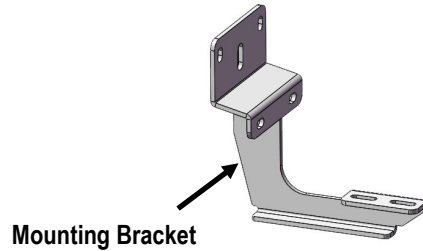

Mounting Bracket

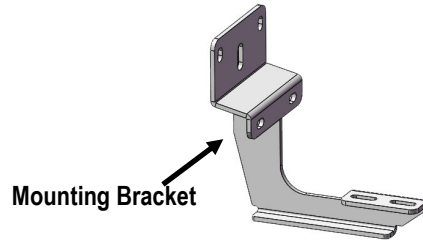

Mounting Bracket

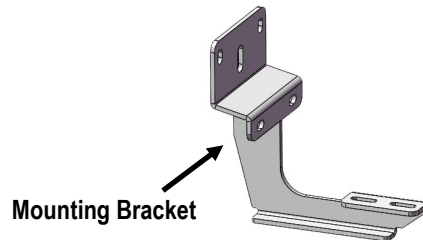

Mounting Bracket

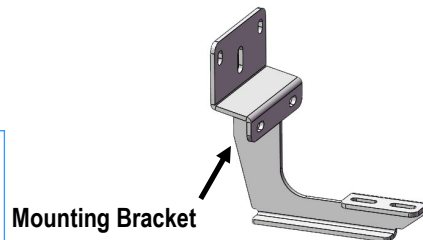

Mounting Bracket

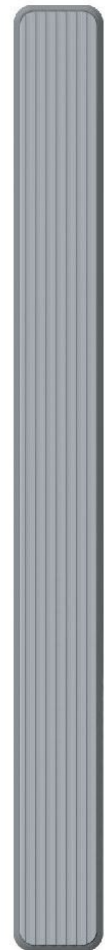

Passenger Side

Note: Driver Front Mounting Bracket and (4) Passenger Side Mounting Brackets are universal

Customer Support: info@iboardauto.com

iBoard®

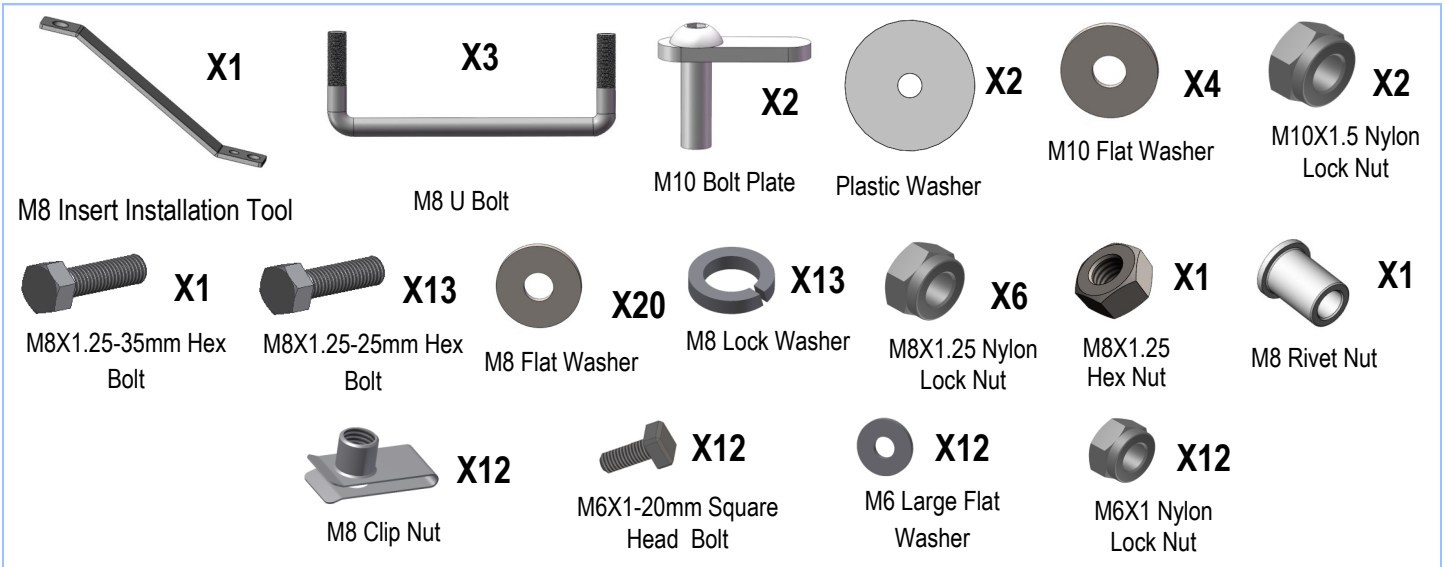

STEP 1

Starting installation from the passenger side front of the vehicle. Release the lower clips from the plastic trim along the bottom of the body, (Fig 1).

NOTE: From below, insert a small or medium sized flat screwdriver into the rectangular hole in the center of the clip. Carefully release each side (inside to outside, not front to back) of the plastic clip and pull the rectangular center pin down from the clip, (Fig 2). Do not twist the clip, gently pull it straight down once the clip is released. It is not necessary to completely remove the trim, only release the clips attaching the bottom of the trim to the vehicle.

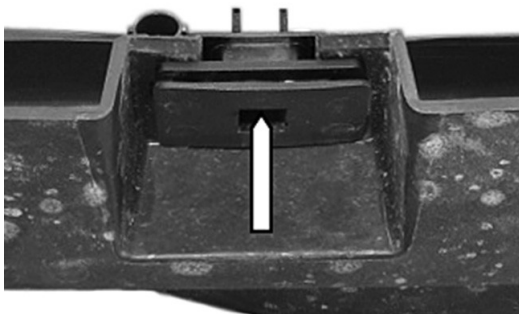

(Fig 1) Insert Flat Screwdriver Into Square Opening to Release the Plastic Clip

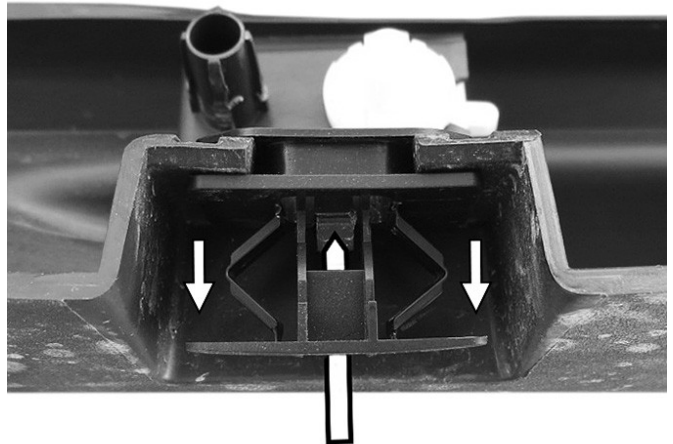

(Fig 2) Release Both Sides Of the Clip to Pull Out The Trim

STEP 2

Locate the factory hole approximately 24" back from the front of the body, (Fig 3). Remove excess undercoating from all mounting locations so that Brackets will install flat against body panel and pinch weld.

iBoard®

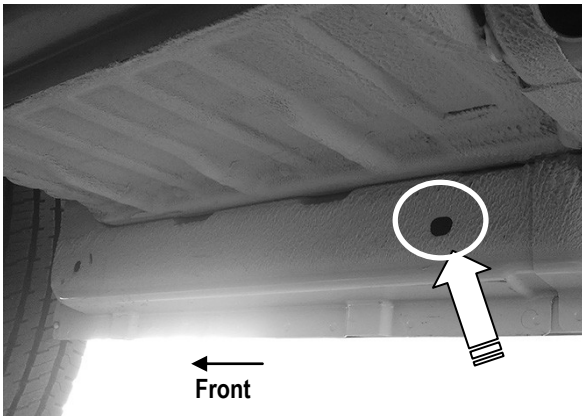

(Fig 3) Passenger Side Front Mounting Bracket Location

STEP 3

Select (1) M10 Bolt Plate, (1) M10 Flat Washer and (1) Plastic Washer. Thread the Plastic Washer onto the M10 Bolt Plate. Insert the M10 Bolt Plate into the hole and tighten the Plastic Washer against the body panel. Slide the M10 Flat Washer onto the end of the Bolt Plate, (Fig 4).

IMPORTANT: The Plastic Washer is designed to prevent the Bolt Plate from falling into the body panel within the Bracket installation. Do not fully tighten hardware at this time.

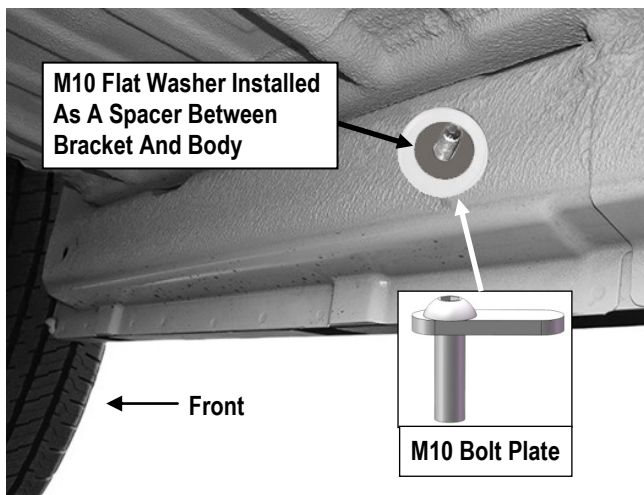

(Fig 4) M10 Bolt Plate Installed on the Passenger Side Front Mounting Location

STEP 4

Select (1) Mounting Bracket. Attach the Mounting Bracket to the installed M10 Bolt Plate with (1) M10 Flat Washer and (1) M10X1.5 Nylon Lock Nut, (Fig 5). Do not fully tighten hardware at this time.

Note: Line up the long slot in the center of the Bracket with the M10 Bolt Plate.

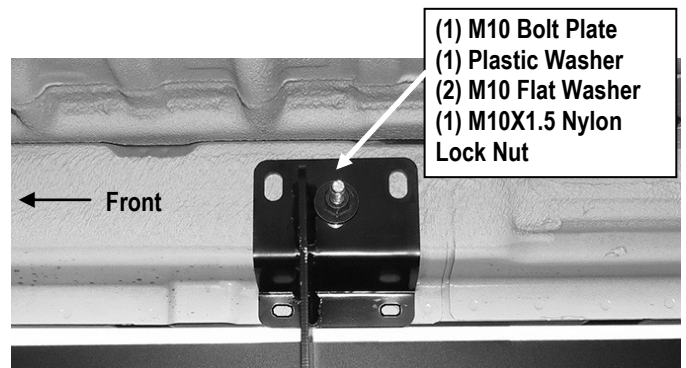

(Fig 5) Passenger Side Front Mounting Bracket Installation

STEP 5

Mark the location of the (2) bottom slots in the Bracket onto the pinch weld, (Fig 5). Remove the Bracket. Use a 3/8" drill bit to drill (2) holes through the pinch weld only, (Fig 6).

NOTE: Drill the holes as far away from the bottom edge of the pinch weld as possible.

IMPORTANT: Do not drill through the welds in the pinch weld. Slide the Bracket forward or back to move the slots away from the factory spot welds. Do not drill into or through the outer plastic rocker panel cover.

IMPORTANT!!! Any cutting or drilling tool may break or shatter. Government regulations require safety glasses & equipment at all times when cutting or drilling.

iBoard®

STEP 6

Select (2) M8 Clip Nuts. Slide the Clip Nuts over the pinch weld with the nut toward the outside, (**Fig 6**). Reattach the Bracket to the Bolt Plate and pinch weld with (2) M8X1.25-25mm Hex Bolts, (2) M8 Lock Washers and (2) M8 Flat Washers, (**Fig 7**). Do not fully tighten hardware at this time.

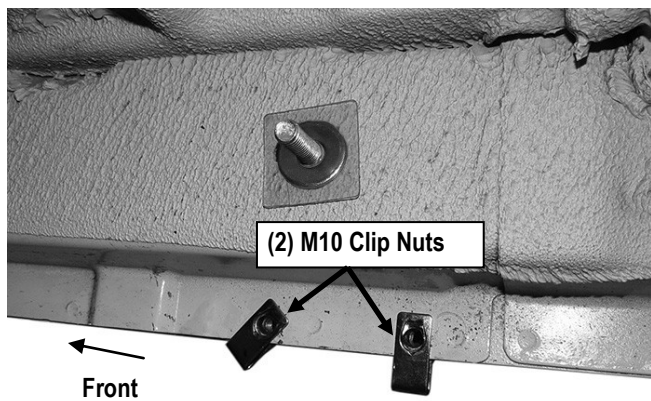

(Fig 6) Slide The Clip Nuts Over The Pinch Weld

(1) M10 Bolt Plate
(1) Plastic Washer
(2) M10 Flat Washer
(1) M10X1.5 Nylon Lock Nut

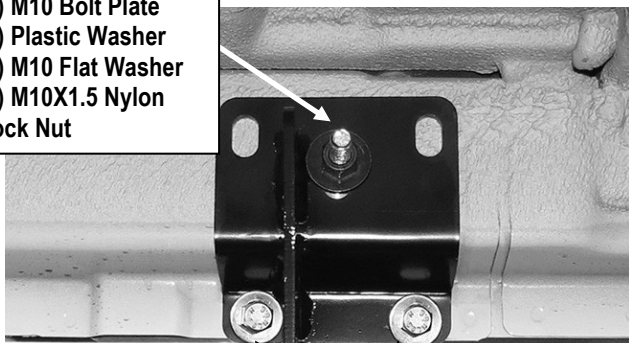

(2) M8 Clip Nuts
(2) M8x1.25-25mm Hex Bolts
(2) M8 Lock Washers
(2) M8 Flat Washers

(Fig 7) Passenger Side Front Mounting Bracket Installation

STEP 7

Move along the body to the 2nd mounting location. Determine if the vehicle is equipped with factory mounting studs along the body panel.

Models without factory studs:

Locate the (2) factory holes in the side of the body panel, (**Fig 8**). Insert (1) M8 U Bolt into the (2) holes, (**Fig 9**). Select (1) Mounting Bracket, attach the Mounting Bracket to the U Bolt with (2) M8 Flat Washers and (2) M8X1.25 Nylon Lock Nuts, (**Figs 10**).

Repeat **Steps 5 & 6** to drill and attach the Mounting Bracket to the inner of the pinch weld, (**Fig 10 & 11**).

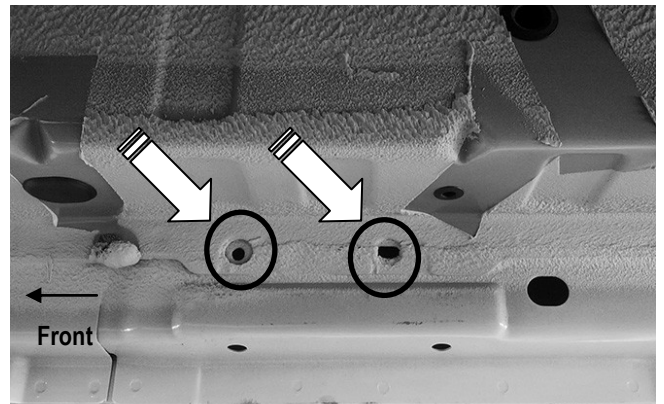

(Fig 8) Passenger Side 2nd Mounting Bracket Location

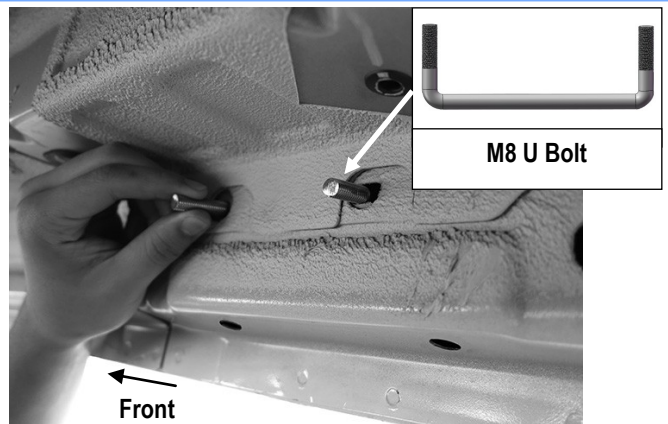

(Fig 9) Insert M8 U Bolt Into Factory Holes In Body Panel

iBoard®

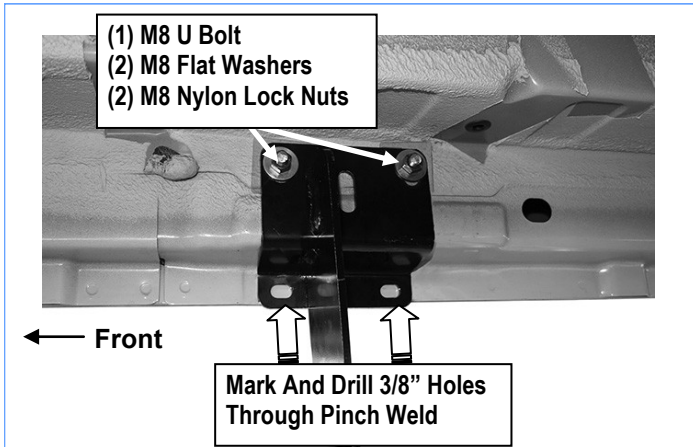

(Fig 10) Passenger Side 2nd Mounting Bracket Installation

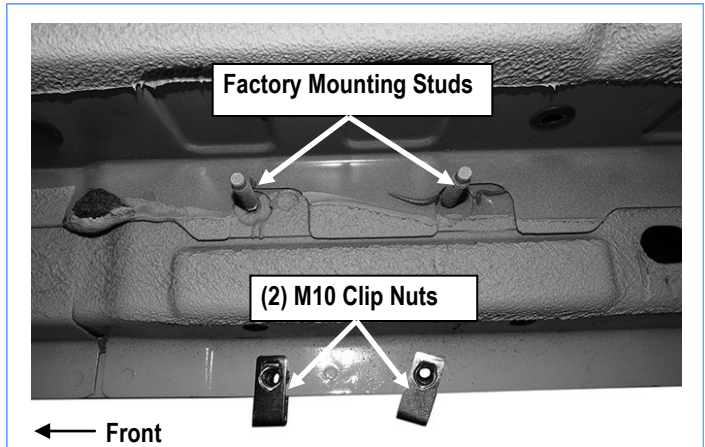

(Fig 12) Passenger Side 2nd Mounting Bracket Location

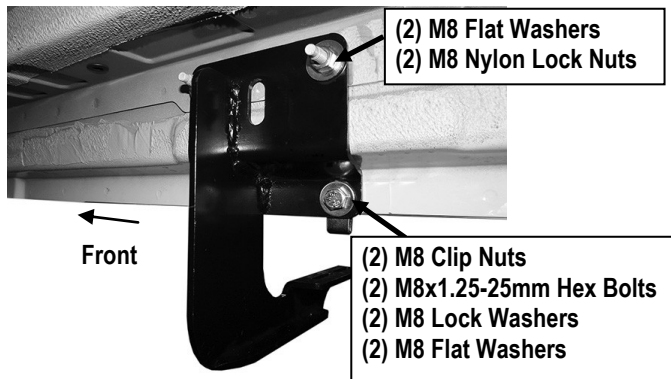

(Fig 11) Passenger Side 2nd Mounting Bracket Installation

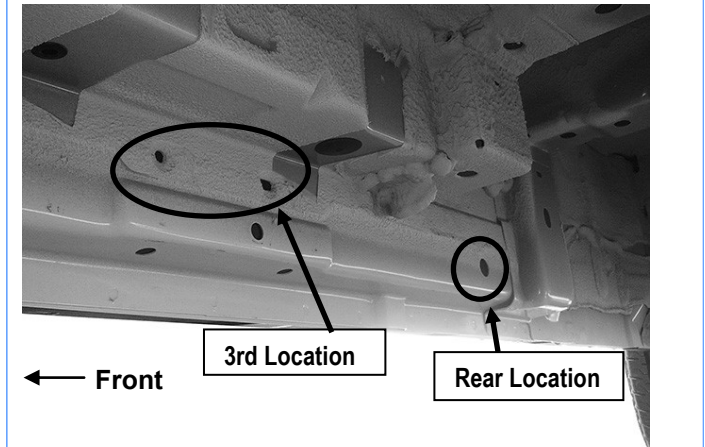

(Fig 13) Passenger Side 3rd/Rear Mounting Bracket Location

Models with factory studs (Fig 12):

Attach (1) Mounting Bracket to the factory studs with (2) M8 Flat Washers and (2) M8X1.25 Nylon Lock Nuts.

Repeat **Steps 5 & 6**, mark and drill holes on the pinch weld, and then insert (2) M10 Clip Nuts into the drilled holes, (**Fig 12**). And reattach the Mounting Bracket to the pinch weld, (**Fig 11**).

Repeat to install (1) Mounting Bracket onto the 3rd mounting location, (**Fig 13**).

STEP 8

Move to the passenger side rear of the vehicle, (**Fig 11**). Repeat **Steps 2—6** to install (1) Mounting Bracket in the passenger side rear mounting location.

iBoard®

STEP 9

Select a Running Board. Slip (4) M6x1-20mm Square Head Bolts into each bottom channel (Fig 14). Carefully position the Running Board onto the (4) Mounting Brackets.

IMPORTANT: Do not slide the Running Board on the Brackets or the bottom surface of the board will be damaged. Attach the Running Board to Mounting Bracket with (8) M6x1-20mm Square Head Bolts, (8) M6 Large Flat Washers and (8) M6 X1 Nylon Lock Nuts (Fig 15). Do not fully tighten hardware at this time.



(Fig 14) Slip M6X1-20mm Square Head Bolts Into The Bottom Channels

- (2) M6X1-20mm Square Head Bolts
- (2) M6 Large Flat Washers
- (2) M6X1 Nylon Lock Nuts

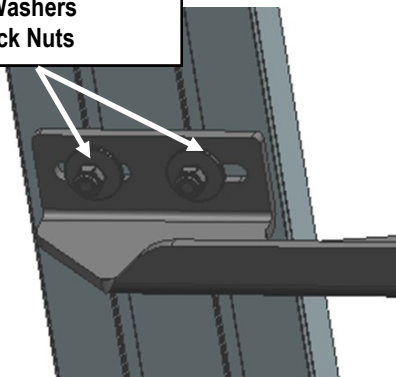

(Fig 15) Running Board Installed Onto Driver Center Mounting Bracket

STEP 10

Level and adjust the Running Board and fully tighten all hardware.

Reinstall the plastic trim along the bottom of the body. **IMPORTANT:** Minor trimming may be required around M8 Clip Nuts. Temporarily remove the Running Board. Use a sharp knife or hacksaw blade to trim plastic as required.

STEP 11

Move to the driver side front of the vehicle. Repeat **Step 1, (Fig 1 & 2)**, to release the clips attaching the plastic trim to the bottom of the driver side. Identify the front bracket mounting location approximately 10" away from the front edge of the body panel, (Fig 16).

Select (1) Mounting Bracket. Hold the Mounting Bracket firmly in position against the body panel and pinch weld. Mark the upper left hole location onto the inner body panel. Also mark the (2) lower mounting locations onto the pinch weld and the drill holes according to the marks, (Fig 16).

IMPORTANT: Do not drill through the welds in the pinch weld. Slide the Bracket forward or back to move the slots away from the factory spot welds. Do not drill into or through the outer plastic rocker panel cover.

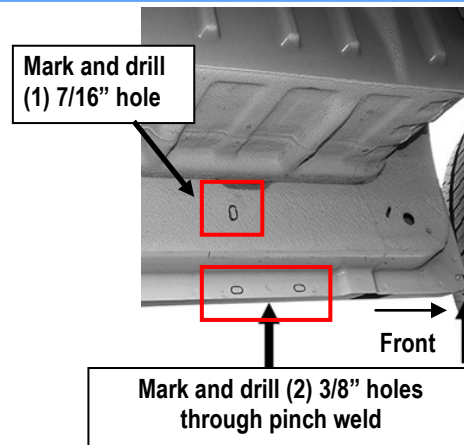

(Fig 16) Driver Side Front Mounting Bracket Location

iBoard®

STEP 12

Select (1) M8 Rivet Nut, (1) M8X1.25-35mm Hex Bolt, (1) M8 Hex Nut, (1) M8 Flat Washer and (1) M8 Insert Tool. Thread the M8 Hex Nut onto the M8 Hex Bolt. Assemble the M8 Insert Tool as pictured in **Fig 17**.

NOTE: Select 8mm hole on M8 Insert Tool (**Fig 18**). Use a 13mm wrench to hold the M8 Hex Bolt to prevent it from spinning. Turn the M8 Hex Nut counter-clockwise to pull/expand the insert in the hole, (**Fig 19**). Tighten the M8 Hex Nut until the Insert is fully installed, (**Figs 17 & 20**). Do not over tighten the M8 Hex Nut.

Bolt the Mounting Bracket to the M8 Rivet Nut with (1) M8x1-25mm Hex Bolt, (1) M8 Lock Washer and (1) M8 Flat Washer, (**Fig 21**).



(Fig 17) M8 Insert Tool Assembly



Hold M8 Hex Bolt in position with wrench.
Turn M8 Hex Nut clockwise to "pull" insert



(Fig 19) M8 Insert Tool Assembly

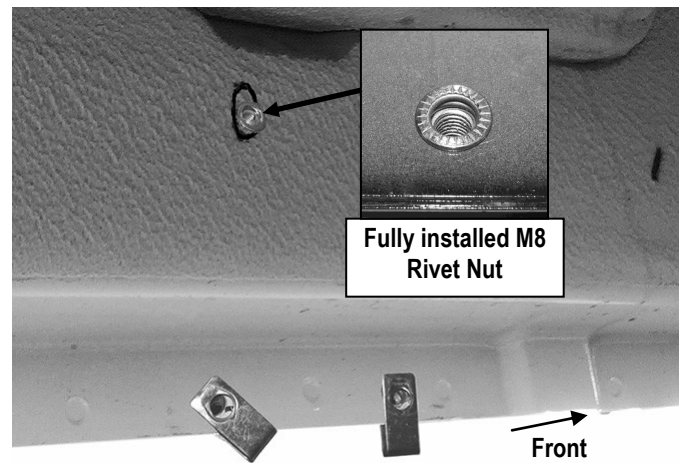

(Fig 20) Driver Side Front Mounting Location

STEP 13

Insert (2) M8 Clip Nuts into the drilled holes on pinch weld, (**Fig 20**). Attach Mounting Bracket to the installed M8 Rivet Nut on body panel, (**Fig 21**). Secure the lower mounting holes to the installed (2) M8 Clip Nuts on pinch weld with (2) M8X1.25-25mm Hex Bolts, (2) M8 Lock Washers and (2) M8 Flat Washers, (**Fig 21**). Do not fully tighten hardware at this time.

iBoard®

- (1) M8x1.25-25mm Hex Bolt
- (1) M8 Lock Washer
- (1) M8 Flat Washer

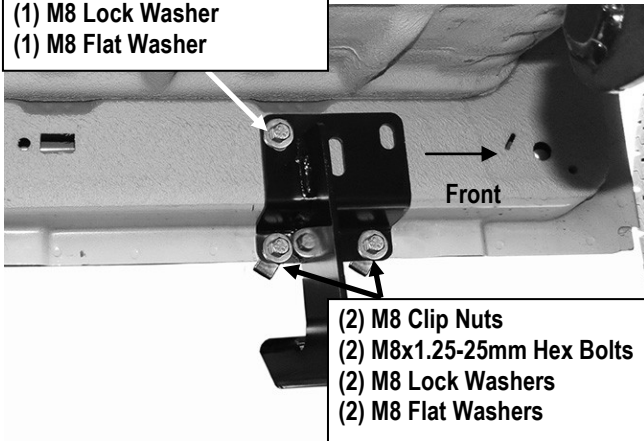

- (2) M8 Clip Nuts
- (2) M8x1.25-25mm Hex Bolts
- (2) M8 Lock Washers
- (2) M8 Flat Washers

(Fig 21) Driver Front Mounting Bracket Installed

STEP 14

Move to the driver side rear mounting location (approximately 24" away from the front edge of the body panel), (Fig 22). Select the Driver Rear Mounting Bracket (DRM). Hold the Bracket firmly against the bottom of the body panel and pinch weld. Mark and drill holes as shown on Fig 22.

NOTE: Slide the Bracket forward as necessary to avoid drilling through any factory welds on the pinch weld.

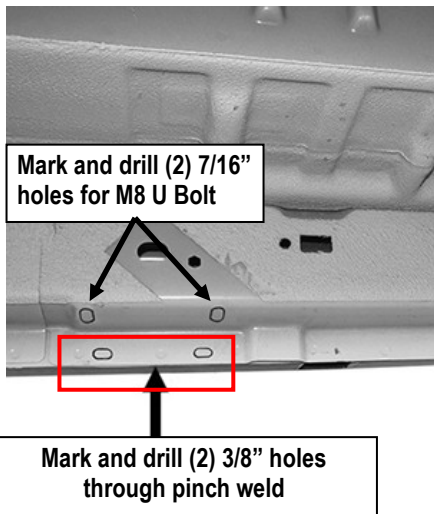

(Fig 22) Driver Side Rear Mounting Location

STEP 15

Insert (1) M8 U Bolt into the (2) drilled 7/16" holes. And insert (2) M8 Clip Nuts into the (2) drilled 3/8" holes on pinch weld.

Select (1) Driver Rear Mounting Bracket (DRM). Attach the upper slots on the Bracket to the installed M8 U Bolt with (2) M8 Flat Washers and (2) M8 Nylon Lock Nuts. Secure the lower holes of the mounting bracket to the installed (2) M8 Clip Nuts on pinch weld with (2) M8x1.25-25mm Hex Bolts, (2) M8 Lock Washers, (2) M8 Flat Washers (Fig 23). Do not fully tighten hardware at this time.

- (1) M8 U Bolt
- (2) M8 Flat Washers
- (2) M8 Nylon Lock Nuts

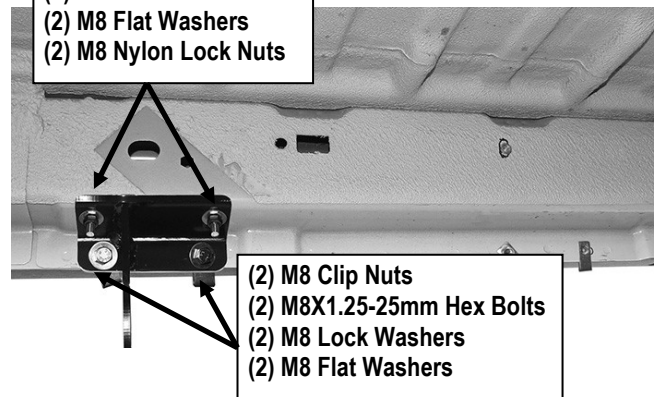

- (2) M8 Clip Nuts
- (2) M8x1.25-25mm Hex Bolts
- (2) M8 Lock Washers
- (2) M8 Flat Washers

(Fig 23) Driver Rear Mounting Bracket (DRM) Installed

STEP 16

Select the driver side Running Board. Repeat Steps 9 & 10 to attach the Running Board to the (2) Brackets.

NOTE: Just need (4) M6x1-20mm Square Head Bolts and (4) M6 Large Flat Washers and (4) M6 Nylon Lock Nuts for the driver side running board installation.

iBoard®

STEP 17

Level and adjust the Running Board and fully tighten all hardware.

Reinstall the plastic trim along the bottom of the body.

IMPORTANT: Minor trimming may be required around M8 Clip Nuts. Temporarily remove the Running Board. Use a sharp knife or hacksaw blade to trim plastic as required.

The installation is completed (Fig 24).

Attention

Do periodic inspections to the installation to make sure that all hardware is secure and tight.

In order to protect your bars/boards, please use only mild soap/non-abrasive products for cleaning.



(Fig 24) Installation Completed