



iBoard® by APS

PART#: IB-210C&H

READ INSTRUCTIONS CAREFULLY BEFORE STARTING INSTALLATION. REMOVE CONTENTS FROM BOX AND VERIFY ALL PARTS ARE PRESENT. ASSISTANCE IS RECOMMENDED.

*ROCKER PANEL MOUNT
*NO DRILLING REQUIRED

Fastener Size	Tightening Torque (ft-lbs)	Required
6mm	6-7	X
8mm	16-18	√
10mm	31-32	√
12mm	56-58	√
7/16"	47-49	√

PART LIST

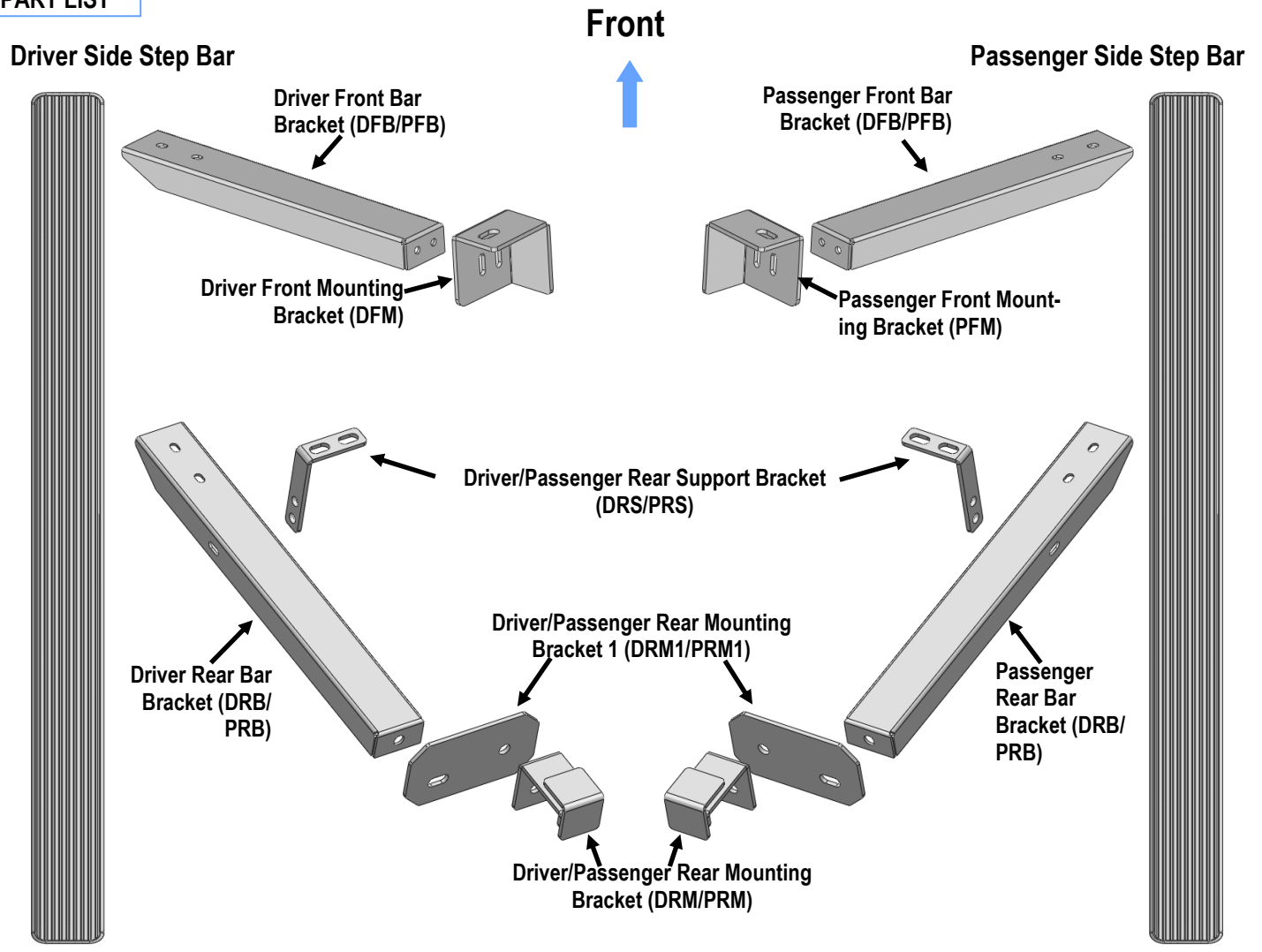

Customer Support: info@iboardauto.com



Hardware Package A (For Bracket Installation)					
Item	QTY	Description	Item	QTY	Description
1#	2	Φ32 Tube Spacers	9#	8	M12 Lock Washers
2#	2	7/16"-20 x 1.75" Fine Thread Coupling Nuts	10#	4	M12X1.75 Hex Nuts
3#	2	7/16"-14 x 1.75" Coarse Thread Coupling Nuts	11#	4	M8X1.25-30mm Hex Bolts
4#	2	7/16"-20 Hex Bolts	12#	2	M8X1.25-20mm Hex Bolts
5#	2	7/16"-14 Hex Bolts	13#	12	M8 Large Flat Washers
6#	2	M10X1.5-25mm Hex Bolts	14#	6	M8 Lock Washers
7#	4	M12X1.75-35mm Hex Bolts	15#	6	M8X1.25 Hex Nuts
8#	12	M12 Flat Washers			

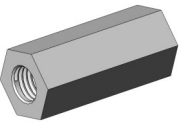

1 #

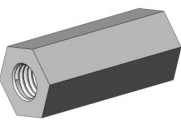

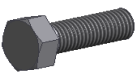
2 #

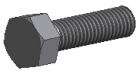

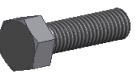
3 #

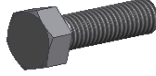

4 #



5 #



6 #



7 #

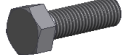

8 #

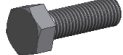

9 #



10 #

11 #



12 #



13 #

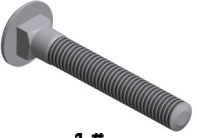

14 #



15 #

Hardware Package B (For Stainless Steel Step Bar Installation)					
Item	QTY	Description	Item	QTY	Description
1#	8	M8X1.25-35mm Carriage Bolts	3#	8	M8 Nylon Lock Nuts
2#	8	M8 Large Flat Washers	4#	4	Sliders (Packed with Step Bars)

1 #

2 #

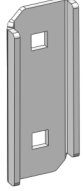
3 #



4 #



STEP 1

Starting under the passenger side of the vehicle, locate the factory front body mount, (Fig 1). Select (1) 7/16"-14 Coarse Thread Coupling Nut. Thread the Coupling Nut onto the exposed end of the body mount bolt, (Fig 2). Tighten hardware at this time.

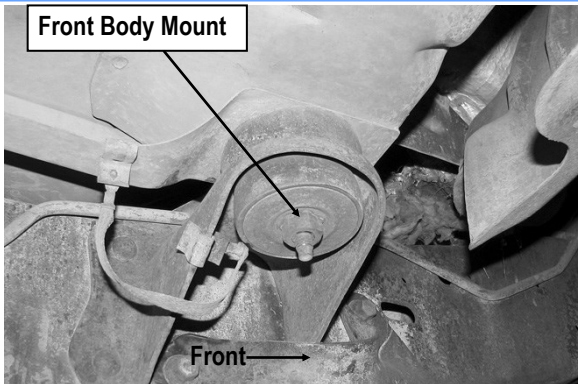
IMPORTANT: The hardware kit includes (4) Coupling Nuts, (2) 7/16"-14 Hex Bolts and (2) 7/16"-20 Hex Bolts. Verify that you have selected the coarse thread Coupling Nut or damage to the body mount bolt or Coupling Nut may result.



(Fig 1) Passenger Side Front Mounting Location

Thread the 7/16" – 14 Coarse Thread Coupling Nut onto threaded end of body bolt

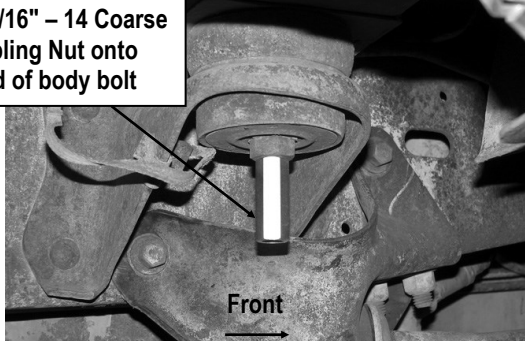

(Fig 2) 7/16"-14 Coarse Thread Coupling Nut Installation

STEP 2

Assemble Passenger Front Mounting Bracket (PFM) and Passenger Front Bar Bracket (DFB/PFB) with (2) M8X1.25-30mm Hex Bolts, (4) M8 Large Flat Washers, (2) M8 Lock Washers and (2) M8x1.25 Hex Nuts, (Fig 3). Do not fully tighten hardware at this time.

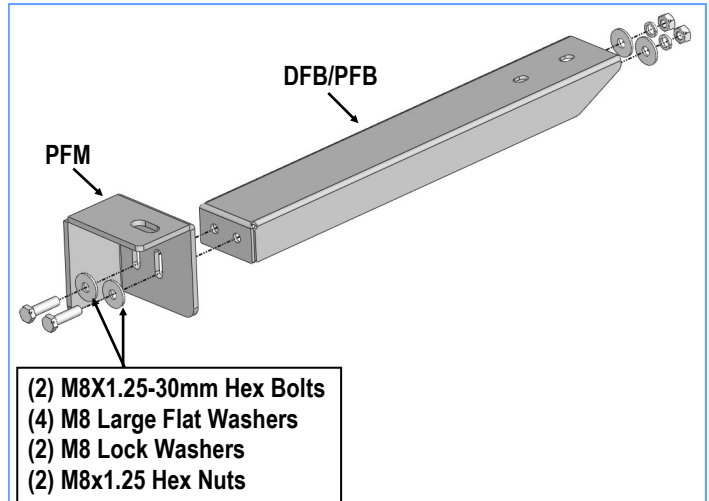

(2) M8X1.25-30mm Hex Bolts
(4) M8 Large Flat Washers
(2) M8 Lock Washers
(2) M8x1.25 Hex Nuts

(Fig 3) Passenger Side Front Brackets Assembly

STEP 3

Next, select the assembled Passenger Front Mounting Bracket (PFM) and (1) Φ 32 Tube Spacer. Slide the Φ 32 Tube Spacer over the Coupling Nut, (Fig 4). Hold the Front Mounting Bracket in position against the Coupling Nut and Spacer. Secure the Bracket to the Coupling Nut with (1) 7/16"-14 Hex Bolt, (1) M12 Flat Washer and (1) M12 Lock Washer.

IMPORTANT: Verify that you have selected the coarse thread 7/16"-14X1.75" Hex Bolt or damage to the Coupling Nut may result. Do not fully tighten hardware at this time.

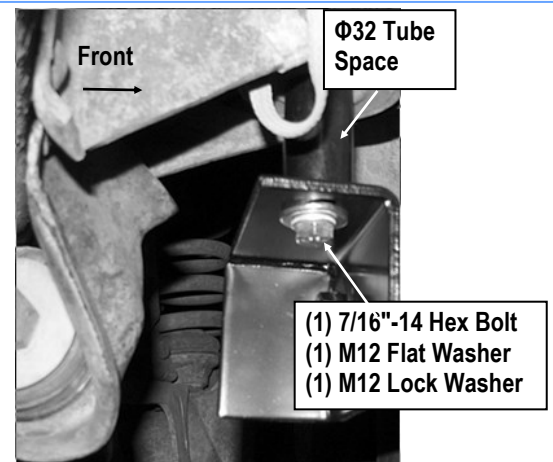

(Fig 4) Passenger Front Mounting Bracket (PFM) Installation



STEP 4

Move to Passenger Side Rear Mounting Location. Select (1) Passenger Rear Mounting Bracket (**DRM/PRM**). Thread (1) M10X1.5-25mm Hex Bolt into the hex nut welded onto the Bracket. Slide the Bracket onto the bottom of the frame rail, (**Fig 5**).

Select (1) Passenger Rear Mounting Bracket 1 (**DRM1/PRM1**). Bolt it to the Passenger Rear Mounting Bracket (**DRM/PRM**) with (1) M12x1.75-35mm Hex Bolt, (2) M12 Flat Washers, (1) M12 Lock Washer and (1) M12x1.75 Hex Nut, (**Fig 6**). Do not fully tighten hardware at this time.

Note: Loosen M10X1.5-25mm Hex Bolt in Passenger Rear Mounting Bracket (**DRM/PRM**) to slide Assembly Bracket forward or backward on frame channel to line up with the end of the Running Board. Once properly lined up, tighten M10X1.5-25mm Hex Bolt.

STEP 5

Select a Passenger Rear Bar Bracket (**DRB/PRB**) and attach to the Passenger Rear Mounting Bracket 1 (**DRM1/PRM1**) with (1) M12x1.75-35mm Hex Bolt, (2) M12 Flat Washers, (1) M12 Lock Washer and (1) M12x1.75 Hex Nut. (**Fig 7 & 10**). Do not fully tighten hardware at this time.

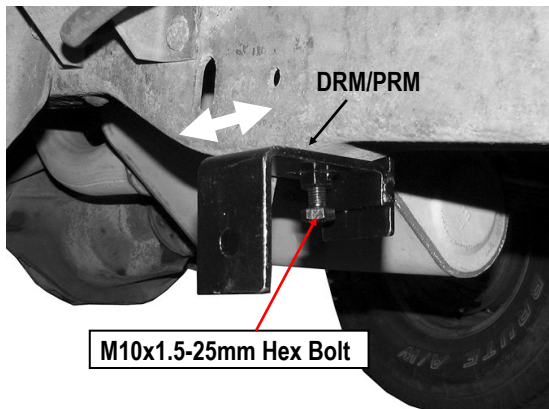

(Fig 5) Passenger Rear Mounting Bracket (DRM/PRM) Installed



(Fig 6) Passenger Rear Mounting Bracket 1 Installed

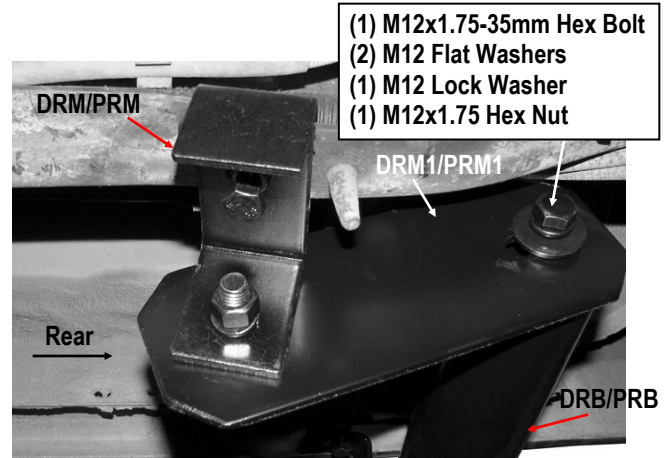

(Fig 7) Passenger Rear Bar Bracket Installed

STEP 6

Locate the exposed threaded end of the outer seat belt bolt in the bottom of the floor panel, (**Fig 8**). Select (1) 7/16"-20 Fine Thread Coupling Nut. Thread the Coupling Nut onto the threaded end of the seat belt bolt. Tighten the Coupling Nut.

Select (1) Passenger Rear Support Bracket (**DRS/PRS**). Bolt the Support Bracket to the Coupling Nut with (1) 7/16"-20 Hex Bolt, (1) M12 Flat Washer and (1) M12 Lock Washer, (**Fig 9**). Then bolt the Passenger Rear Support Bracket (**DRS/PRS**) to the Passenger Rear Bar Bracket (**DRB/PRB**) with (1) M8X1.25-20mm Hex Bolt, (2) M8 Flat Washers, (1) M8 Lock Washer and (1) M8x1.25 Hex Nut, (**Fig 10**).

IMPORTANT: Verify that you have selected the 7/16-20 Hex Bolt or damage to the Bolt or Coupling Nut may result. Do not fully tighten hardware at this time.



Thread the 7/16" – 20 Fine
Thread Coupling Nut onto
threaded end of seat belt bolt

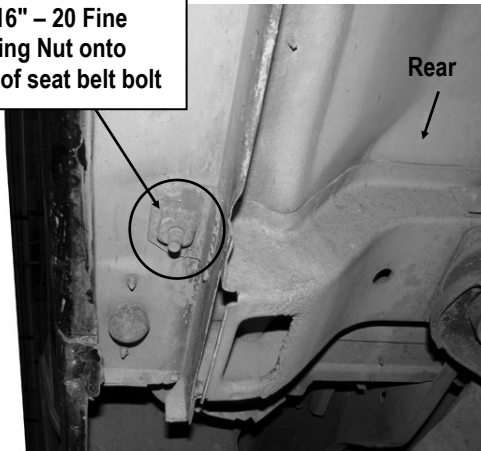

(Fig 8) Thread The 7/16" – 20 Fine Thread Coupling Nut Onto Threaded End Of Seat Belt Bolt

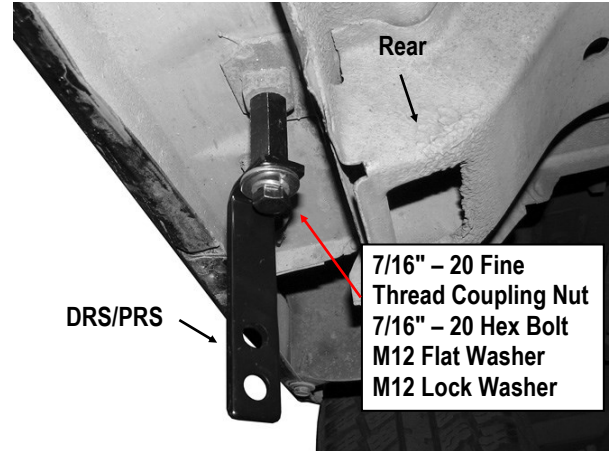

(Fig 9) Passenger Rear Support Bracket Installation

(Fig 10) Passenger Side Rear Brackets Assembly

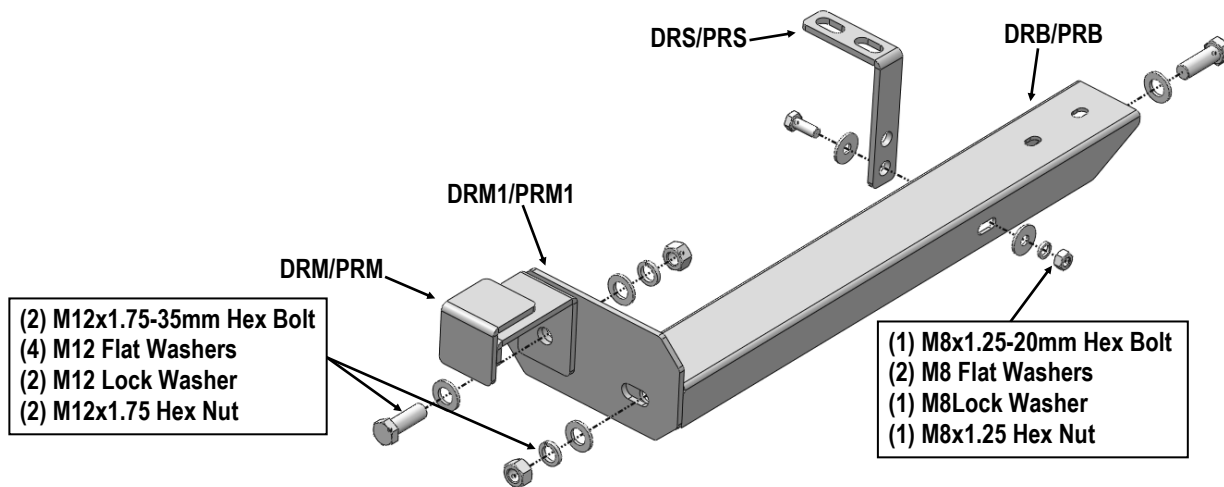



STEP 7

Once all (2) Passenger side mounting brackets are installed, then proceed to the Step Bar installation. **(Figs 11 & 12)**

- (1) Select (1) Slider and (2) M8X1.25-35mm Carriage Bolts;
- (2) Install (2) M8X1.25-35mm Carriage Bolts in (1) Slider.
- (3) Slide the Slider (with carriage bolts) to the **Step Bar**.
- (4) Repeat to install the other (1) slider to the step bar.
- (5) Attach the Step Bar (with the Sliders) onto the installed mounting brackets. Position the Sliders to the installed brackets. Secure the Step Bar to the installed Brackets by using (4) M8 Large Flat Washers and (4) M8 Nylon Lock Nuts and (2) Sliders, **(Fig 12)**. Do not fully tighten hardware at this time.

Note: The Sliders are packed with the Step Bars.

Level and adjust the Step Bar and fully tighten all hardware.

Repeat **Steps 1-7** for the other side Step Bar installation. **The installation is completed!!!**

Attention

Do periodic inspections to the installation to make sure that all hardware is secure and tight.

In order to protect your bars/boards, please use mild soap/non-abrasive products for cleaning only.

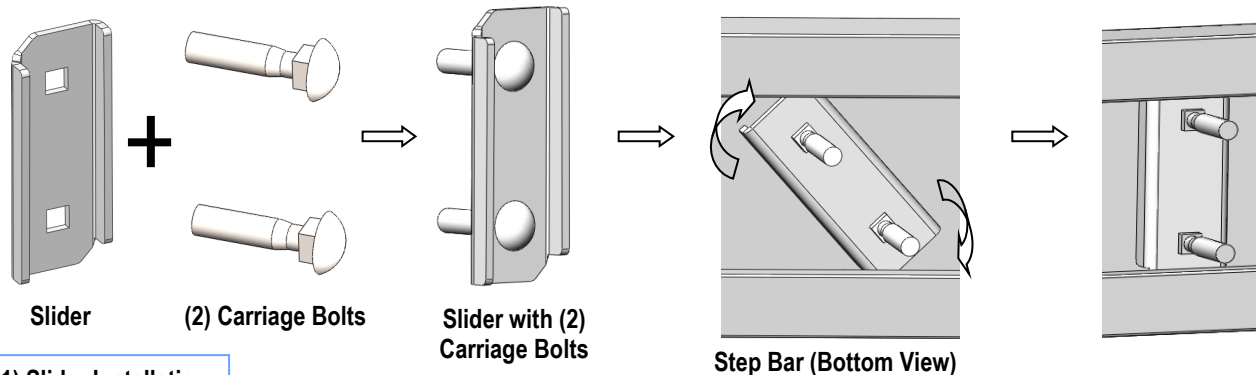

(Fig 11) Slider Installation

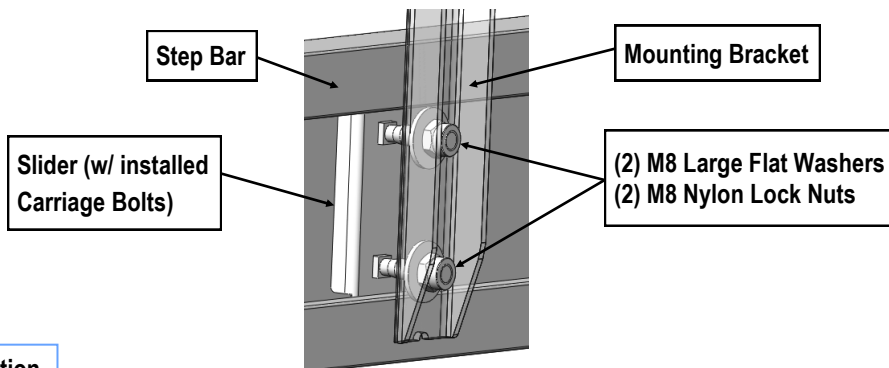

(Fig 12) Step Bar Installation