

# iBoard®

## iBoard® by APS

PART#: IB-080

READ INSTRUCTIONS CAREFULLY BEFORE STARTING INSTALLATION. REMOVE CONTENTS FROM BOX AND VERIFY ALL PARTS ARE PRESENT. ASSISTANCE IS RECOMMENDED.

\*ROCKER PANEL MOUNT  
\*DRILLING / TRIMMING MAY BE REQUIRED

Fastener Size	Tightening Torque (ft-lbs)	Required
6mm	6-7	√
8mm	16-18	X
10mm	31-32	√
12mm	56-58	X
14mm	92-94	X

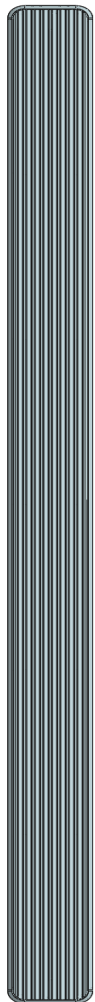

Driver Side Step Bar

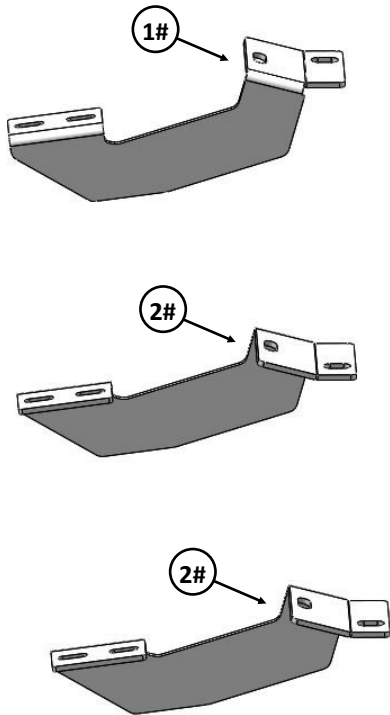

Front  
↑

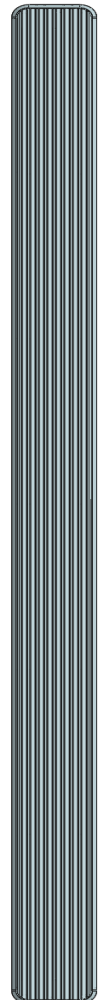
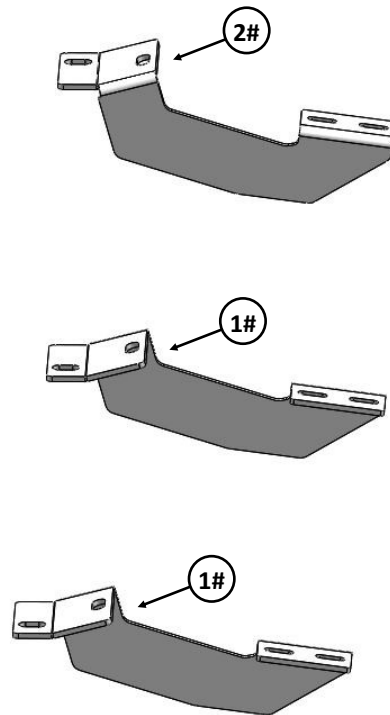



Passenger Side Step Bar

# iBoard®

Mounting Bracket List					
Item	QTY	Description	Item	QTY	Description
1#	3	Driver Front / Passenger Center & Rear Mounting Brackets	2#	3	Passenger Front / Driver Center & Rear Mounting Brackets

Hardware Package A (For Bracket Installation)					
Item	QTY	Description	Item	QTY	Description
1#	4	85mm Tube Spacers	6#	6	M10 Flat Washers
2#	2	65mm Tube Spacers	7#	12	M10 Lock Washers
3#	4	M10X1.5-120mm Hex Bolts	8#	6	M10 Hex Nuts
4#	2	M10X1.5-110mm Hex Bolts	9#	6	M10 Clip Nuts
5#	6	M10X1.5-30mm Hex Bolts			

 1#

 3#

 4#

 5#

 6#

 2#

 7#

 8#

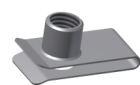
 9#

Hardware Package B (For Aluminum Step Bar Installation Only, Not Supply to SS. Step Bar)					
Item	QTY	Description	Item	QTY	Description
1#	12	M6X1-20mm Square Head Bolts	3#	12	M6 Nylon Lock Nuts
2#	12	M6 Large Flat Washers			

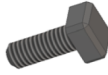
 1 #

 2 #

 3#

Hardware Package C (For Stainless Steel Step Bar Installation Only, Not Supply to Aluminum Step Bar)					
Item	QTY	Description	Item	QTY	Description
1#	12	M6X1-20mm Hex Bolts	3#	12	M6 Flat Washers
2#	12	M6 Lock Washers			

 1 #

 2 #

 3 #

# iBoard®

## STEP 1

**NOTE:** On vehicles with running boards, running boards must be removed. On vehicles without running boards, remove plastic trim and mount plates fastened to bottom of rocker panel. Use 7/16" socket to remove tin nuts and screwdriver to remove plastic clips holding mount plate.

Start installation from the driver side front of the vehicle. Locate the (2) front factory holes on the driver side floor panel located by the front tire. With the threaded nut facing up, insert (1) M10 Clip Nut through larger hole. Lineup M10 Clip Nut into the smaller hole (**Fig 1**).

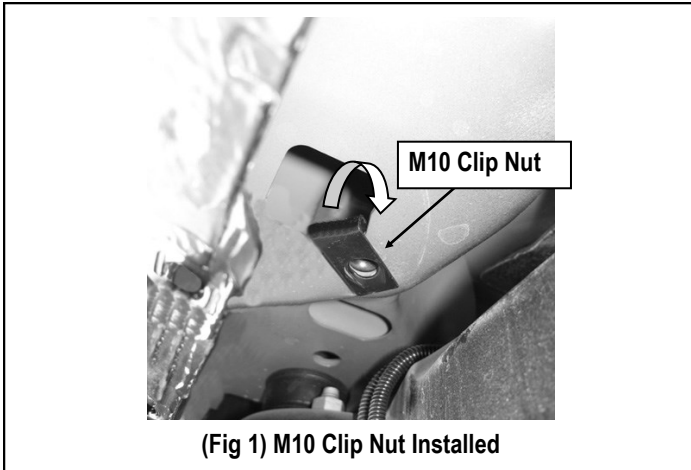

## STEP 2

**On vehicles without rear air and heat:**

Select (1) Driver Front Mounting Bracket. Place (1) 65mm Tube Spacer between the Driver Front Mounting Bracket and the installed M10 Clip Nut. Insert (1) M10X1.5-110mm Hex Bolt to the installed M10 Clip Nut through tab on the Mounting Bracket and 65mm Tube Spacer (**Fig 2**). Do not fully tighten hardware at this time. Attach Driver Front Mounting Bracket to pinch weld using (1) M10X1.5-30mm Hex Bolt, (1) M10 Lock Washer, (2) M10 Flat Washers and (1) M10 Hex Nut, (**Figs 2 & 3**). Do not fully tighten hardware at this time.

**NOTE:** If vehicles equipped with factory step boards, the existing factory stud and nut can be used. If factory hardware is not present, use fasteners provided.

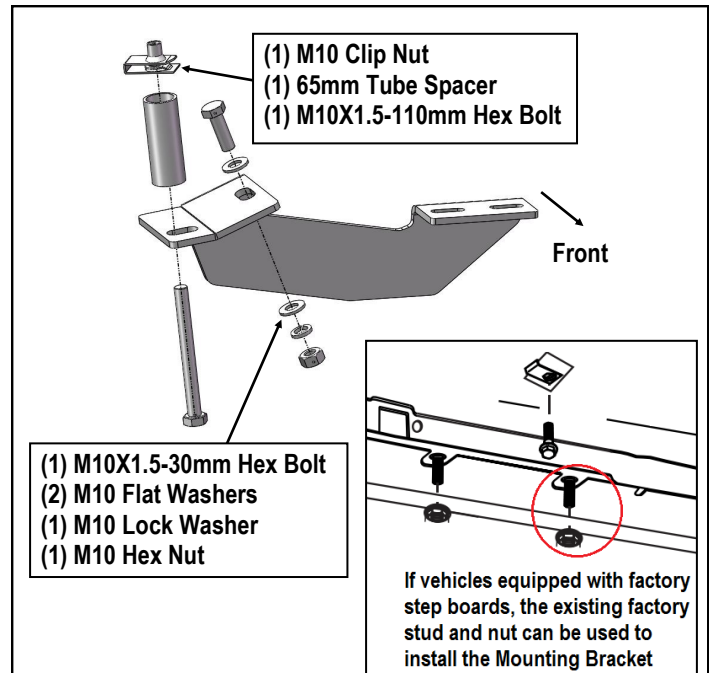

(Fig 2) Driver Side Front Mounting Bracket Installation

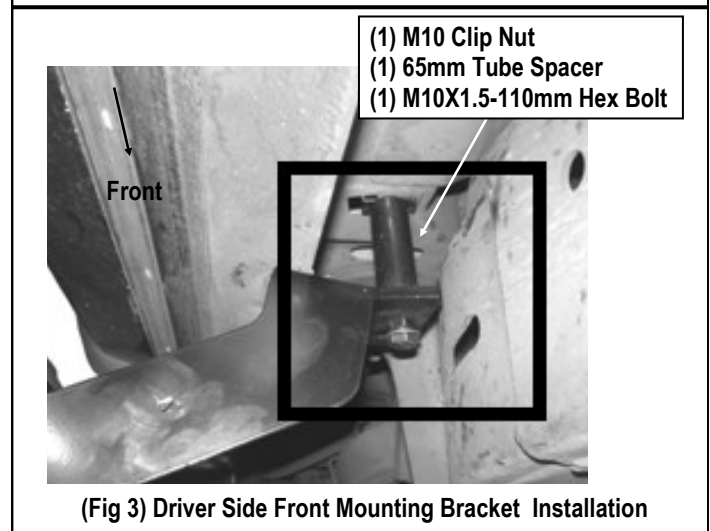

## STEP 3

**On vehicles without Factory Step boards and with rear air and heat:**

The plastic studs will need to be trimmed and a 5/16" hole drilled through the plastic where the stud was. Insert bolts through these holes, (**Fig 4**).

**NOTE:** Be careful not to drill into the air conditioning lines.

# iBoard®

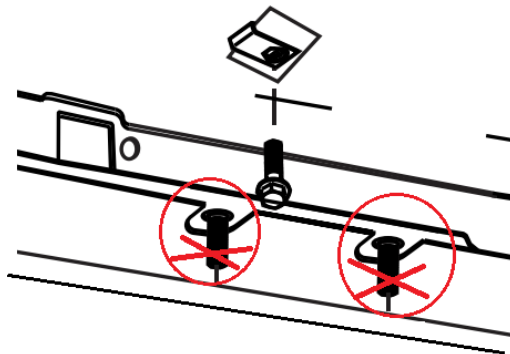

Vehicles without Factory Step boards and with rear air and heat, The plastic studs will need to be trimmed and a 5/16" hole drilled

Fig 4

## STEP 4

Move to the center & rear mounting location. Repeat **Steps 1 – 4** for driver center and rear Mounting Brackets.

**IMPORTANT:** Depending upon your vehicle, the center factory hole might be too small for the M10 Clip Nut, file the Clip Nut until you are able to mount it. .

**NOTE:** 85mm Tube Spacers with M10X1.5-120mm Hex Bolts will be used on the center and rear Mounting Brackets.

## STEP 5

Once all (3) mounting brackets are installed, then proceed to the Step Bar installation. According to the style of Step Bar proceed to the correct installation STEPS.

**Note:** Aluminum Step Bar refer to **STEP 6**; Stainless Steel Step Bar skip to **STEP 7**.

## STEP 6

### Aluminum Step Bar Installation:

Select a **Aluminum Step Bar**. Slip (3) M6x1-20mm Square Head Bolts into each bottom channel (**Fig 5**). Carefully position the Step Bar onto the (3) Mounting Brackets.

**IMPORTANT:** Do not slide the Step Bar on the Brackets or the bottom surface of the board will be damaged. Attach the Step Bar to each Mounting Brackets with (2) M6x1-20mm Square Head Bolts, (2) M6 Large Flat Washers and (2) M6 Nylon Lock Nuts, (**Fig 6**). Do not fully tighten at this time.

Level and adjust the Step Bar and fully tighten all hardware.

Repeat **Steps 1-6** for the other side Step Bar installation. **The installation is completed!!!**



(Fig 5) Slip M6X1-20mm Square Head Bolts Into The Bottom Channels

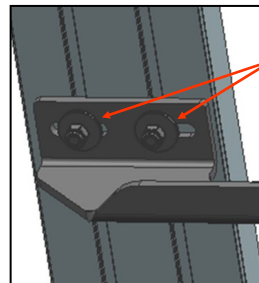

(2) M6X1-20mm Square Head Bolts  
(2) M6 Large Flat Washers  
(2) M6 Nylon Lock Nuts  
**IMPORTANT: TORQUE FOR 6MM FASTNERS MUST LESS THAN 6-7 FT-LBS OR THE FASTNERS WILL BE DAMAGED!**

(Fig 6) Step Bar Installed Onto Mounting Bracket

## STEP 7

### Stainless Steel Step Bar Installation:

Select a **Stainless Steel Step Bar** (with the U-Sliders installed on the Bar). Loose the U-Sliders, reposition the U-Sliders onto the board according to the (3) Installed Mounting Brackets location, (**Fig 7**). Re-secure the U-Sliders on the Step Bar. Attach the Step Bar to the installed Mounting Brackets with (6) M6X1-20mm Hex Bolts, (6) M6 Large Flat Washers & (6) M6 Lock Washers, (**Fig 8**). Do not fully tighten hardware at this time.

# iBoard®

Level and adjust the Step Bar and fully tighten all hardware.  
Repeat **Steps 1-5 and 7** for the other side Step Bar installation.  
**The installation is completed!!!**



(Fig 7) Slide & line up the U-Slider with the installed mounting brackets along bottom channel

(2) M6X1-20mm Hex Bolts  
(2) M6 Large Flat Washers  
(2) M6 Lock Washers  
**IMPORTANT: TORQUE FOR 6MM FASTNERS MUST LESS THAN 6-7 FT-LBS OR THE FASTNERS WILL BE DAMAGED!**

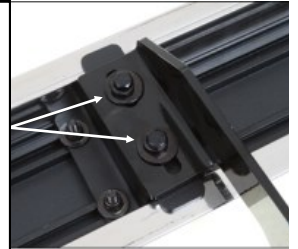

(Fig 8) Step Bar Installed on Bracket Installed

### Attention

Do periodic inspections to the installation to make sure that all hardware is secure and tight.

In order to protect your bars/boards, please use only mild soap/non-abrasive products for cleaning.