

iBoard®

iBoard® by APS

PART#: IB-210A-B

READ INSTRUCTIONS CAREFULLY BEFORE STARTING INSTALLATION. REMOVE CONTENTS FROM BOX AND VERIFY ALL PARTS ARE PRESENT. ASSISTANCE IS RECOMMENDED.

*ROCKER PANEL MOUNT
*NO DRILLING REQUIRED

Fastener Size	Tightening Torque (ft-lbs)
6mm	6-7
8mm	16-18
10mm	31-32
12mm	56-58
14mm	92-94

PART LIST

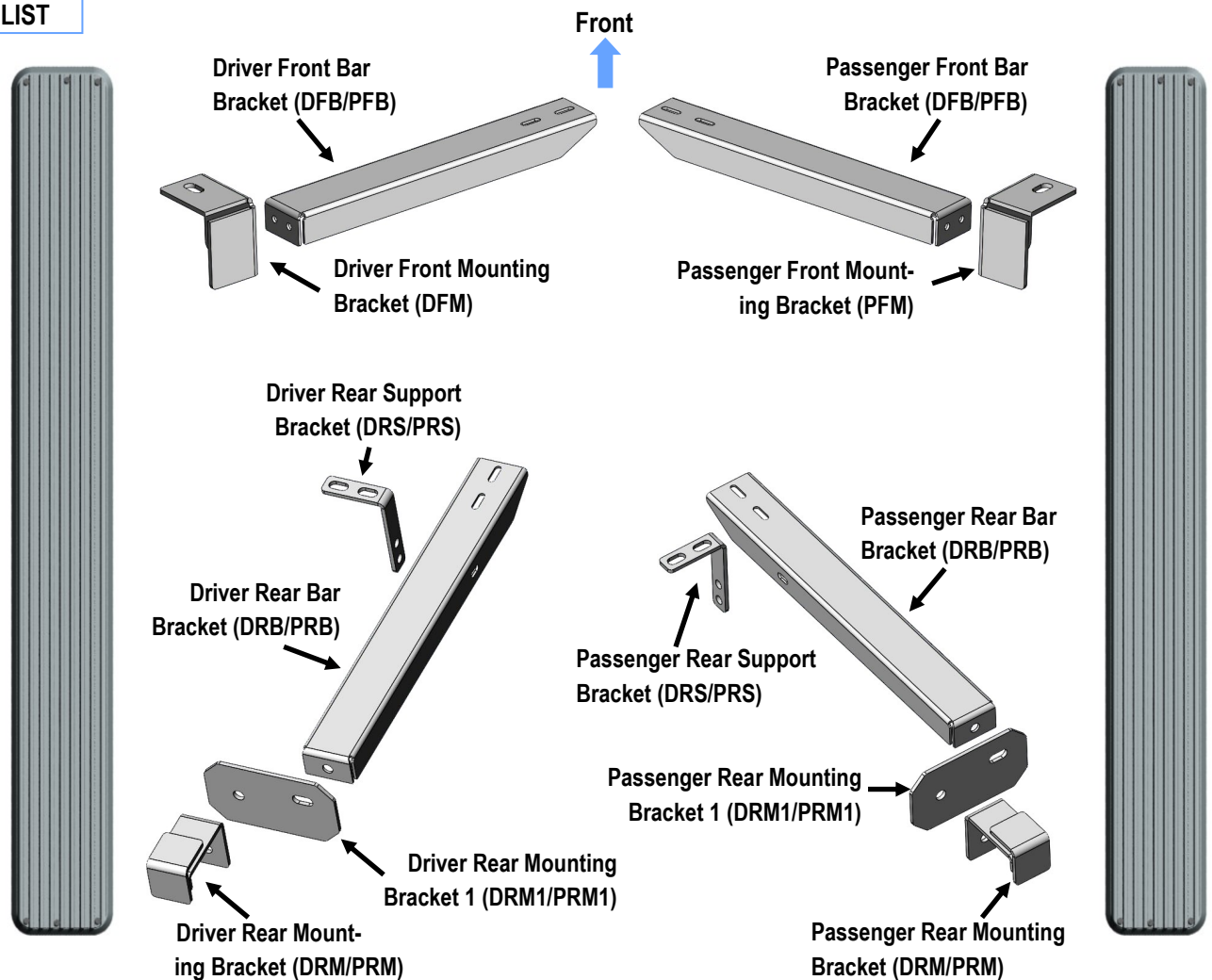

Customer Support: info@iboardauto.com

iBoard®

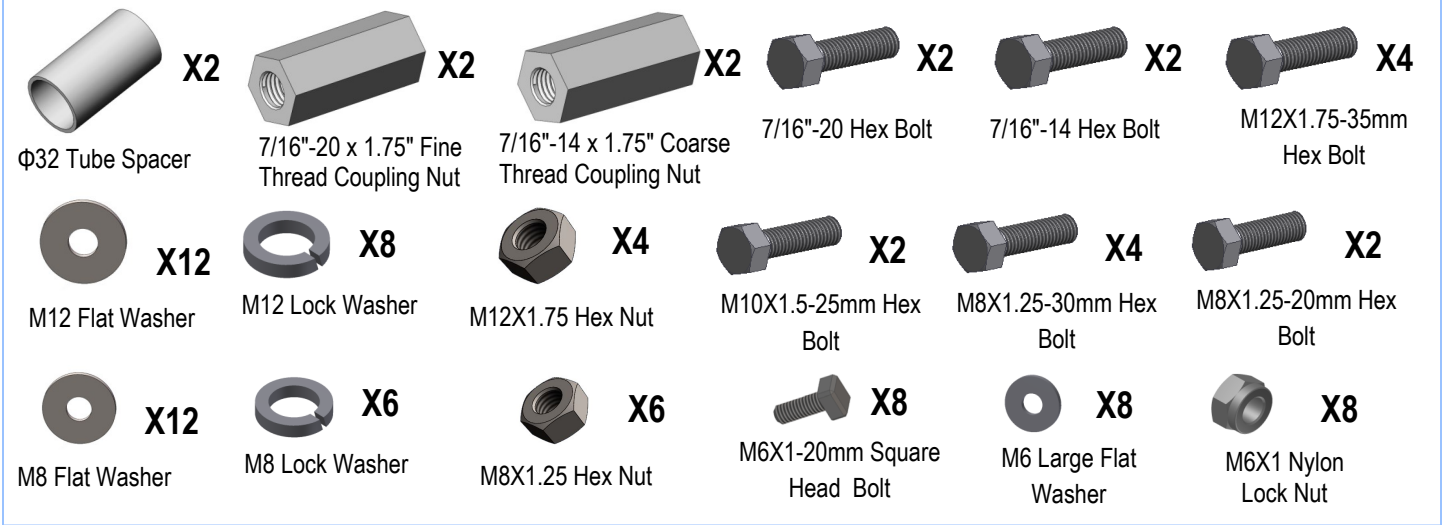

STEP 1

Starting under the passenger side of the vehicle, locate the factory front body mount, (Fig 1). Select (1) 7/16\"-14 Coarse Thread Coupling Nut.

IMPORTANT: The hardware kit includes (4) Coupling Nuts, (2) 7/16\"-14 Hex Bolts and (2) 7/16\"-20 Hex Bolts. Verify that you have selected the coarse thread Coupling Nut or damage to the body mount bolt or Coupling Nut may result. Thread the Coupling Nut onto the exposed end of the body mount bolt, (Fig 2). Tighten hardware at this time.

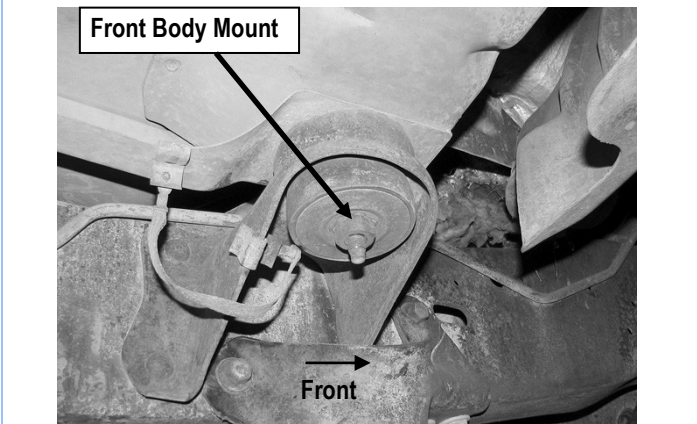

(Fig 1) Passenger Side Front Mounting Location

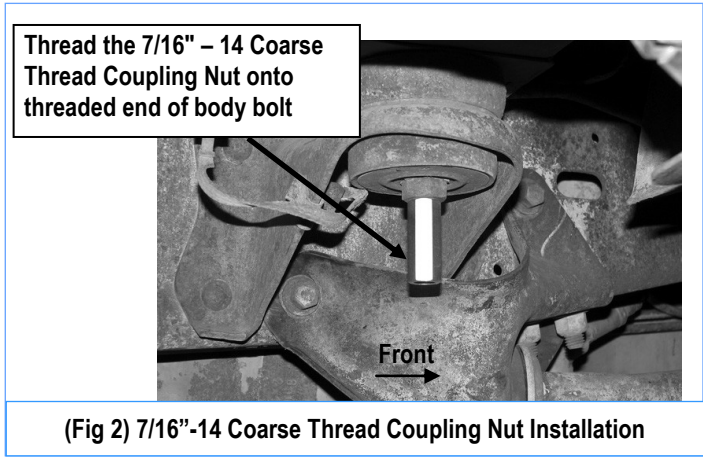

(Fig 2) 7/16\"-14 Coarse Thread Coupling Nut Installation

STEP 2

Assemble Passenger Front Mounting Bracket (PFM) and Passenger Front Bar Bracket (DFB/PFB) with (2) M8X1.25-30mm Hex Bolts, (4) M8 Flat Washers, (2) M8 Lock Washers and (2) M8x1.25 Hex Nuts, (Fig 3). Do not fully tighten hardware at this time.

iBoard®

STEP 4

Move to Passenger Side Rear Mounting Location. Select (1) Passenger Rear Mounting Bracket (**DRM/PRM**). Thread (1) M10X1.5-25mm Hex Bolt into the hex nut welded onto the Bracket. Slide the Bracket onto the bottom of the frame rail, (**Fig 5**).

Select (1) Passenger Rear Mounting Bracket 1 (**DRM1/PRM1**). Bolt it to the Passenger Rear Mounting Bracket (**DRM/PRM**) with (1) M12x1.75-35mm Hex Bolt, (2) M12 Flat Washers, (1) M12 Lock Washer and (1) M12x1.75 Hex Nut, (**Fig 6**). Do not fully tighten hardware at this time.

Note: Loosen M10X1.5-25mm Hex Bolt in Passenger Rear Mounting Bracket (**DRM/PRM**) to slide Assembly Bracket forward or backward on frame channel to line up with the end of the Running Board. Once properly lined up, tighten M10X1.5-25mm Hex Bolt.

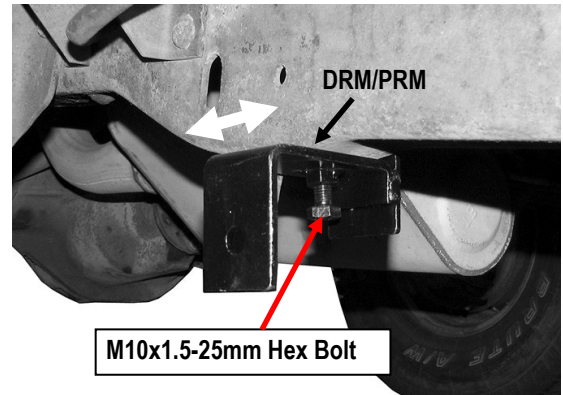

(Fig 5) Passenger Rear Mounting Bracket (DRM/PRM) Installation

- (1) M12x1.75-35mm Hex Bolt
- (2) M12 Flat Washers
- (1) M12 Lock Washer
- (1) M12x1.75 Hex Nut

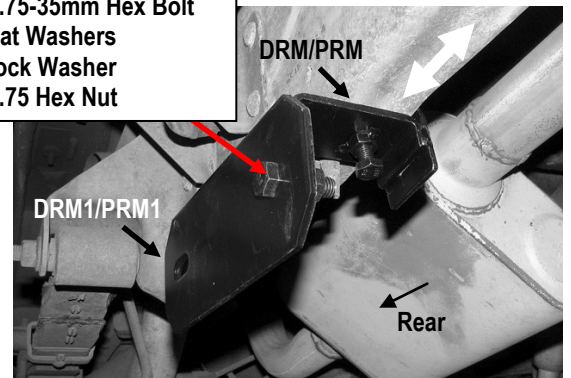

(Fig 6) Passenger Rear Mounting Bracket 1 Installation

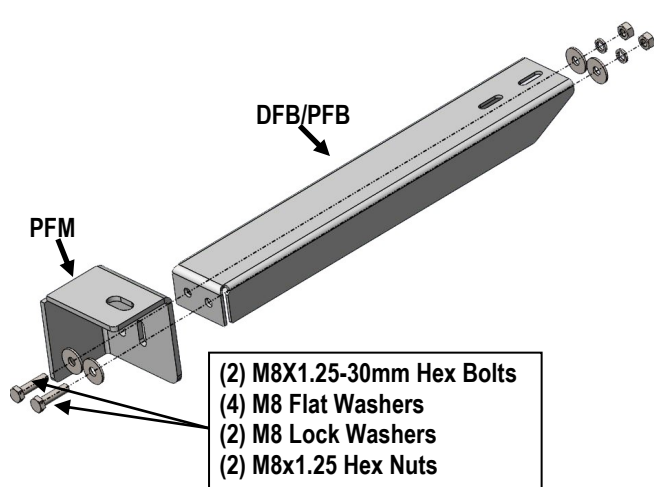

(Fig 3) Passenger Side Front Brackets Assembly

STEP 3

Next, select the assembled Passenger Front Mounting Bracket (**PFM**) and (1) Φ 32 Tube Spacer. Slide the Φ 32 Tube Spacer over the Coupling Nut, (**Fig 4**). Hold the Front Mounting Bracket in position against the Coupling Nut and Spacer. Secure the Bracket to the Coupling Nut with (1) 7/16"-14 Hex Bolt, (1) M12 Flat Washer and (1) M12 Lock Washer.

IMPORTANT: Verify that you have selected the coarse thread 7/16"-14X1.75" Hex Bolt or damage to the Coupling Nut may result. Do not fully tighten hardware at this time.

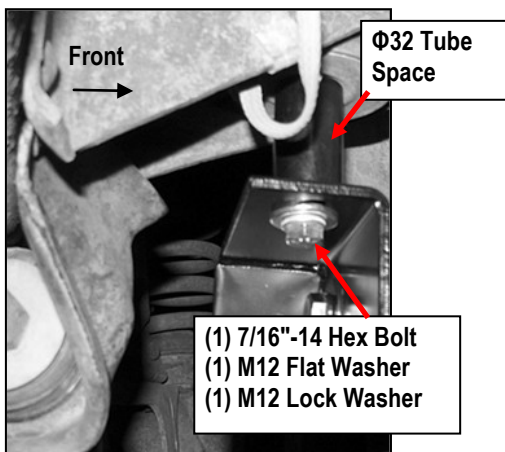

(Fig 4) Passenger Front Mounting Bracket (PFM) Installation

iBoard®

STEP 5

Select a Passenger Rear Bar Bracket (**DRB/PRB**) and attach to the Passenger Rear Mounting Bracket 1 (**DRM1/PRM1**) with (1) M12x1.75-35mm Hex Bolt, (2) M12 Flat Washers, (1) M12 Lock Washer and (1) M12x1.75 Hex Nut. (**Fig 7 & 10**). Do not fully tighten hardware at this time.

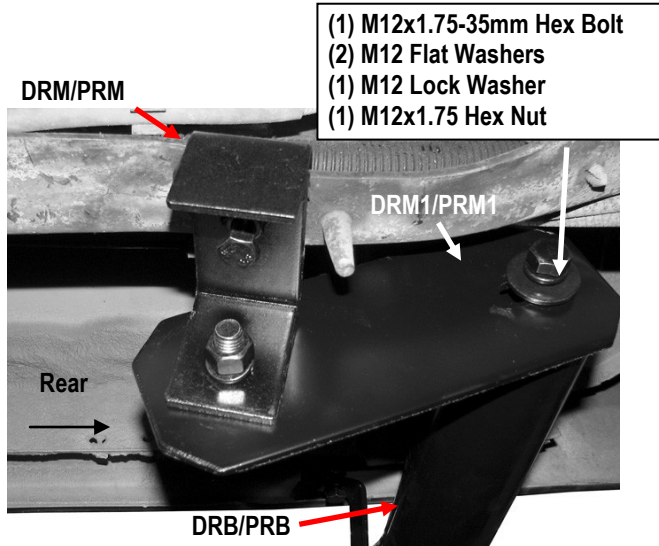

(Fig 7) Passenger Rear Bar Bracket Installation

STEP 6

Locate the exposed threaded end of the outer seat belt bolt in the bottom of the floor panel, (**Fig 8**). Select (1) 7/16"-20 Fine Thread Coupling Nut. Thread the Coupling Nut onto the threaded end of the seat belt bolt. Tighten the Coupling Nut.

Select (1) Passenger Rear Support Bracket (**DRS/PRS**). Bolt the Support Bracket to the Coupling Nut with (1) 7/16"-20 Hex Bolt, (1) M12 Flat Washer and (1) M12 Lock Washer, (**Fig 9**). Then bolt the Passenger Rear Support Bracket (**DRS/PRS**) to the Passenger Rear Bar Bracket (**DRB/PRB**) with (1) M8x1.25-20mm Hex Bolt, (2) M8 Flat Washers, (1) M8 Lock Washer and (1) M8x1.25 Hex Nut, (**Fig 10**).

IMPORTANT: Verify that you have selected the 7/16-20 Hex Bolt or damage to the Bolt or Coupling Nut may result. Do not fully tighten hardware at this time.

Thread the 7/16" – 20 Fine Thread Coupling Nut onto threaded end of seat belt bolt

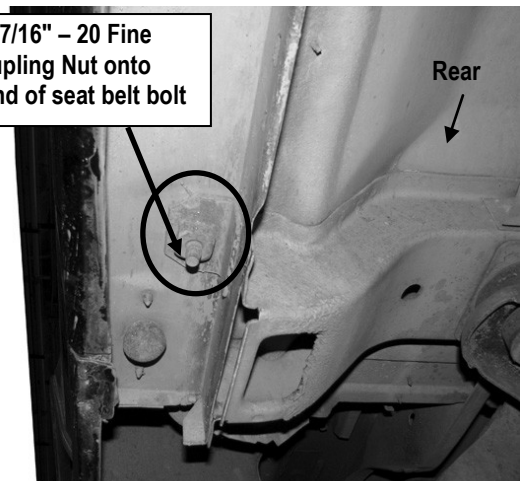

(Fig 8) Thread The 7/16" – 20 Fine Thread Coupling Nut Onto Threaded End Of Seat Belt Bolt

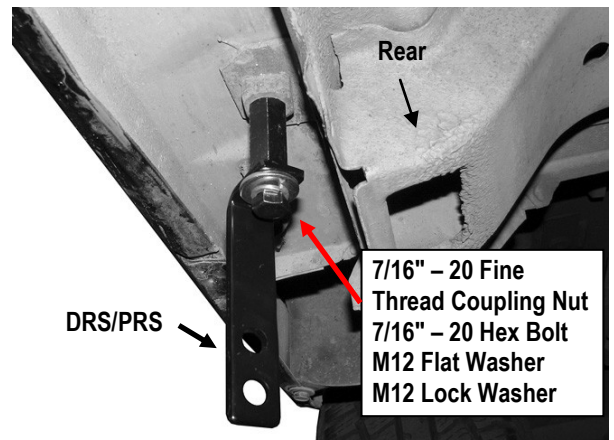

(Fig 9) Passenger Rear Support Bracket Installation

STEP 7

Select a Running Board. Slip (2) M6x1-20mm Square Head Bolts into each bottom channel (**Fig 11**). Carefully position the Running Board onto the (2) Mounting Brackets.

IMPORTANT: Do not slide the Running Board on the Brackets or the bottom surface of the board will be damaged. Attach the Running Board to Mounting Bracket with (2) M6x1-20mm Square Head Bolts, (2) M6 Large Flat Washers and (2) M6 X1 Nylon Lock Nuts (**Fig 12**). Do not fully tighten at this time. Level and adjust the Running Board and fully tighten all hardware.

iBoard®

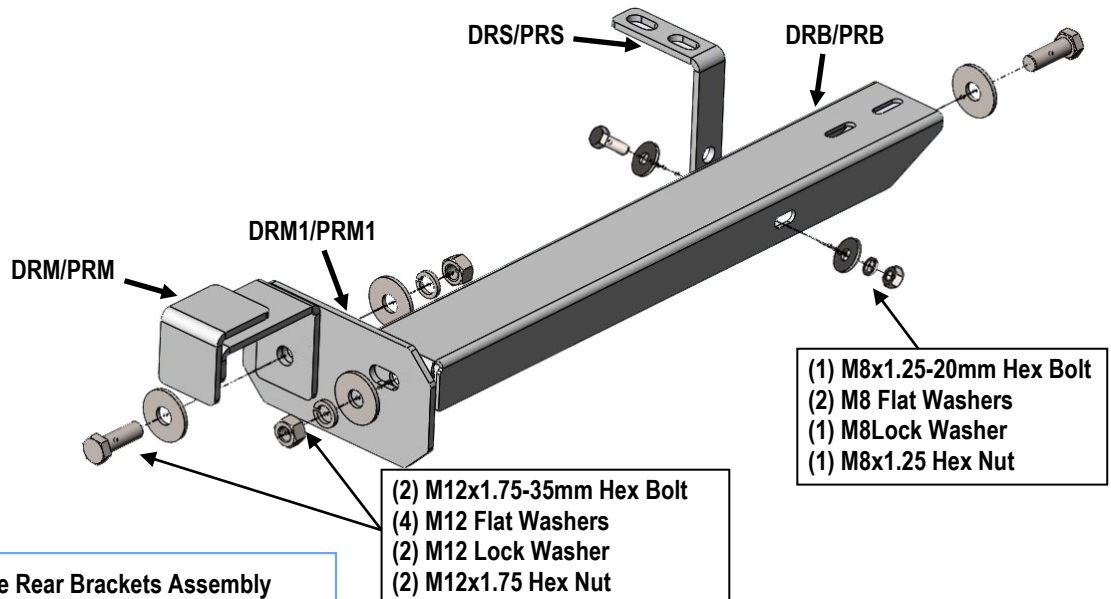

(Fig 10) Passenger Side Rear Brackets Assembly



(Fig 11) Slip M6X1-20mm Square Head Bolts Into The Bottom Channels

- (2) M6X1-20mm Square Head Bolts
- (2) M6 Large Flat Washers
- (2) M6X1 Nylon Lock Nuts

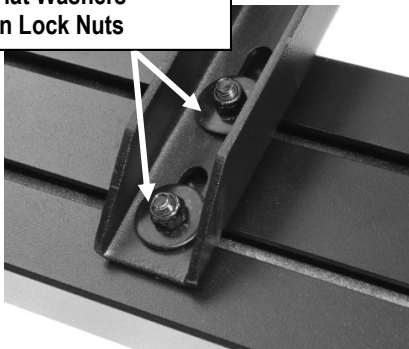

(Fig 12) Running Board Installed Onto Driver Center Mounting Bracket

STEP 8

Repeat **Steps 1-7** for the other side Running Board installation. The installation is completed (**Fig 13**).



(Fig 13) Installation Completed

Attention

Do periodic inspections to the installation to make sure that all hardware is secure and tight.

In order to protect your bars/boards, please use only mild soap/non-abrasive products for cleaning.