

iBoard®

iBoard® by APS

PART#: IB-138

READ INSTRUCTIONS CAREFULLY BEFORE STARTING INSTALLATION. REMOVE CONTENTS FROM BOX AND VERIFY ALL PARTS ARE PRESENT. ASSISTANCE IS RECOMMENDED.

*BODY FRAME MOUNT

*DRILLING IS REQUIRED/ CUTTING IS REQUIRED

Fastener Size	Tightening Torque (ft-lbs)	Required
6mm	6-7	√
8mm	16-18	√
10mm	31-32	√
12mm	56-58	X
14mm	92-94	X

PART LIST

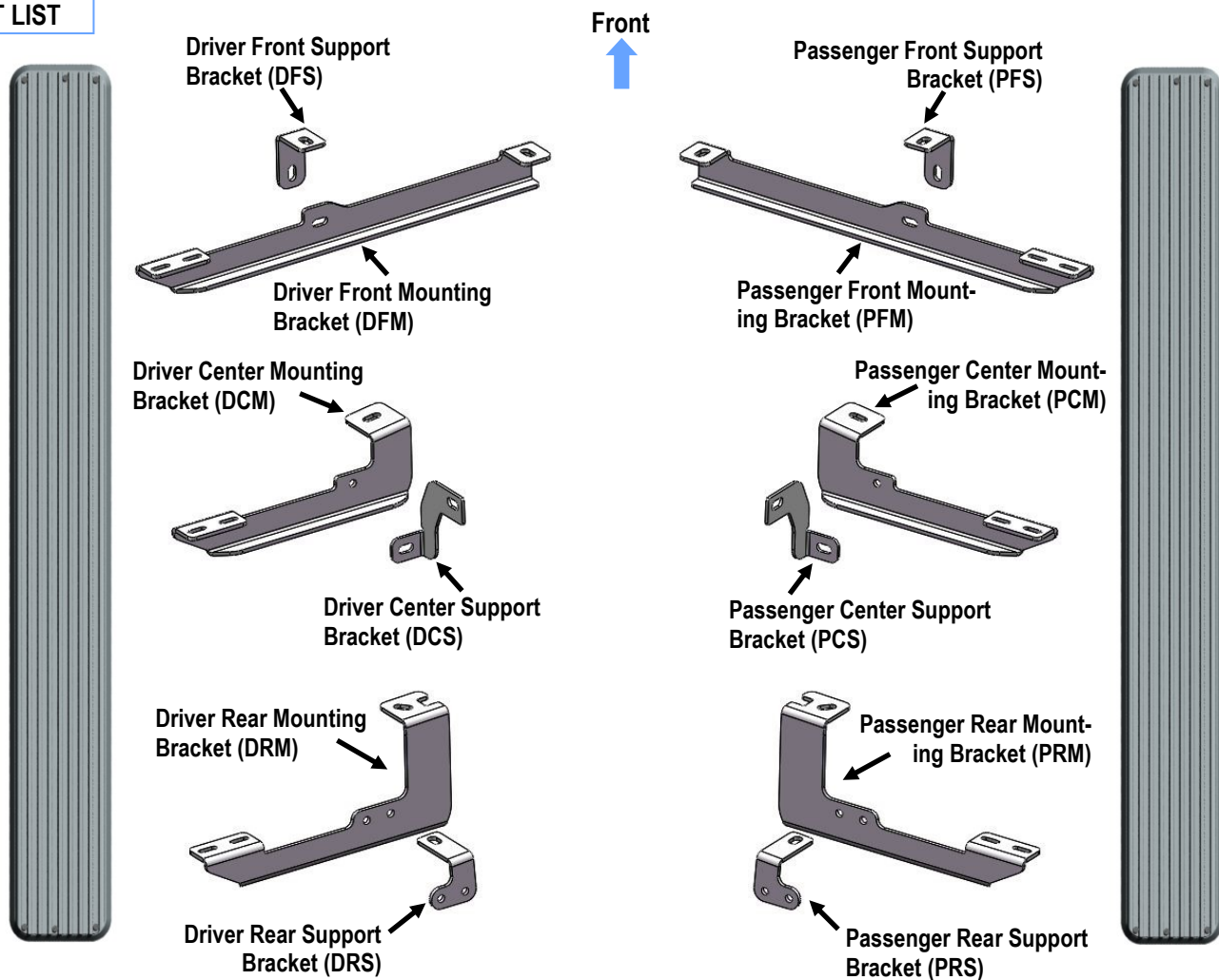

Customer Support: info@iboardauto.com

iBoard®

Hardware Package A (For Bracket Installation)

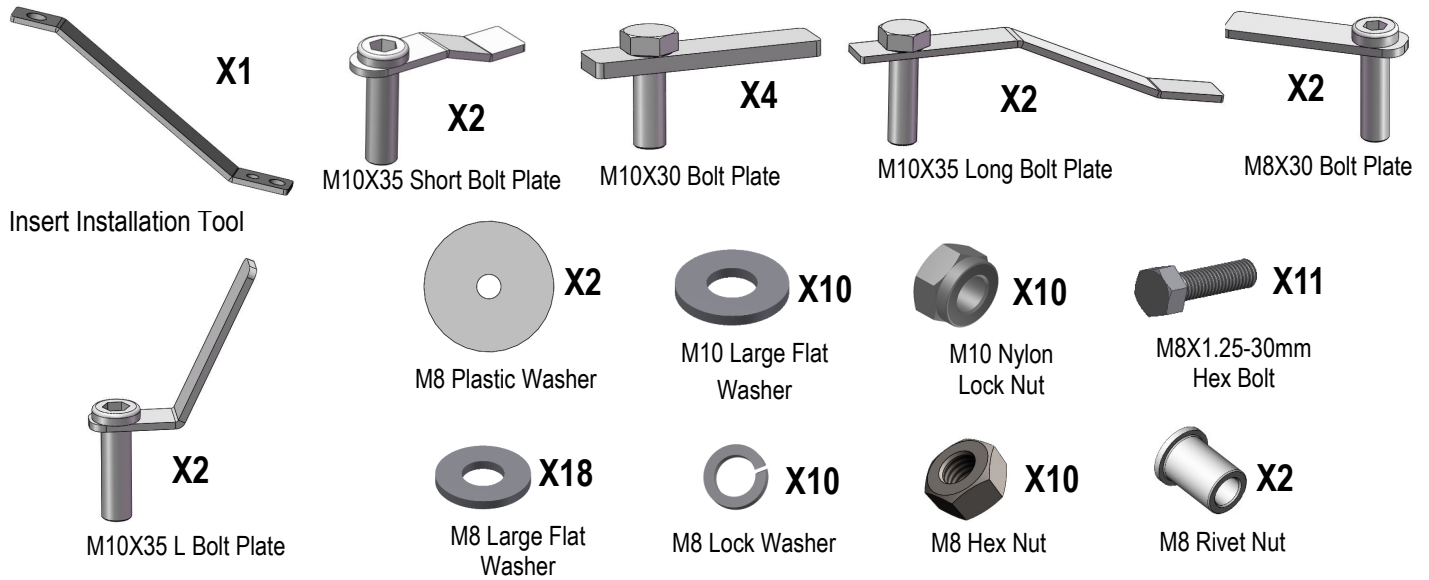

Hardware Package B (For Aluminum Step Bar Installation Only, Not Supply to Stainless Steel Step Bar)



Hardware Package C (For Stainless Steel Step Bar Installation Only, Not Supply to Aluminum Step Bar)



iBoard®

STEP 1

Start installation from the driver side front of the vehicle. Locate an oval hole at the bottom of the body panel close to the front wheel. Insert (1) M10X30 Bolt Plate into the factory hole, (**Fig 1**).

Attach the Driver Front Support Bracket (**DFS**) to the installed M10X30 Bolt Plate with (1) M10 Large Flat Washer and (1) M10 Nylon Lock Nut, (**Fig 2**). Do not fully tighten hardware at this time.

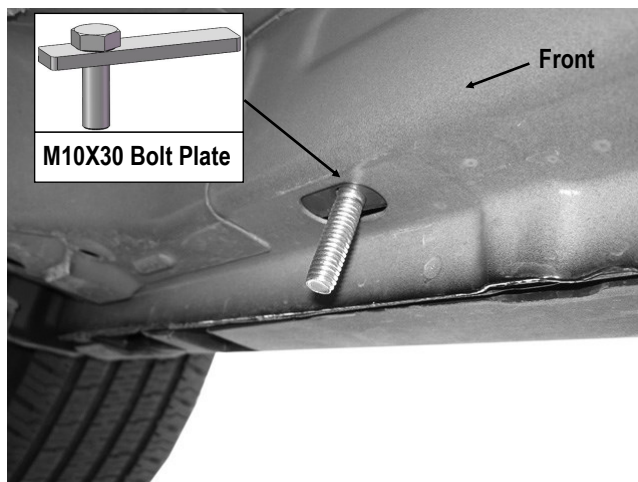

(Fig 1) Driver Side Front Mounting Location

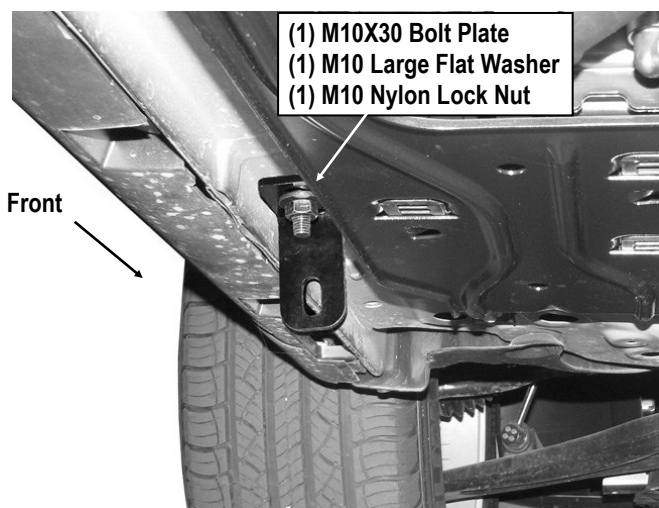

(Fig 2) Driver Front Support Bracket Installed

STEP 2

Move to the Driver Side Front Mounting location. Locate the oval and square holes at the bottom of the inner frame channel, (**Fig 3**). Insert (1) M10X35 Long Bolt Plate into the oval hole through the square hole (**Fig 3**).

Note: Temporarily remove the plastic cover if equipped.

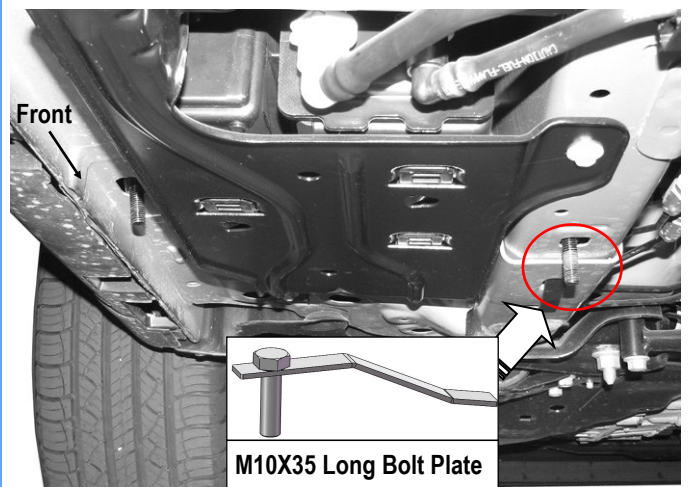

(Fig 3) Insert M10X35 Long Bolt Plate
(on the Driver Side Front Mounting Location)

STEP 3

Move to the Driver Side Center Mounting Location (**Fig 4**). Insert (1) M10X35 L Bolt Plate to the oval hole through the vertical slot in the back of the reinforcement, (**Fig 4**). Attach the Driver Center Mounting Bracket (**DCM**) to the Installed Bolt Plate with (1) M10 Large Flat Washer and (1) M10 Nylon Lock Nut, (**Fig 6**). Do not fully tighten hardware at this time.

iBoard®

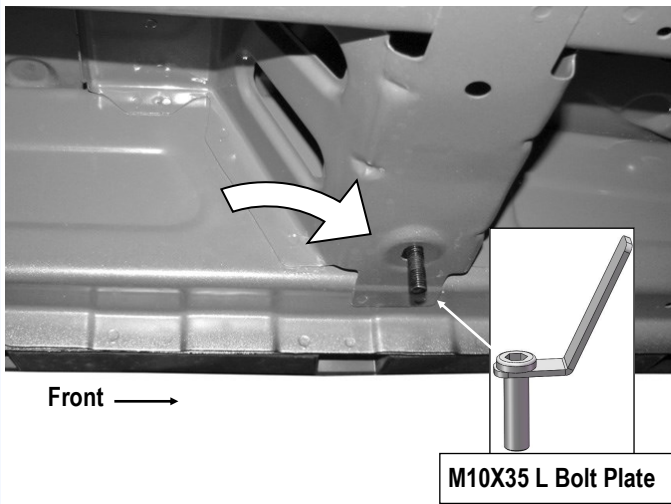

(Fig 4) Driver Side Center Mounting Location (2007-2011 Models)

STEP 4

Determine the correct Center Support Bracket procedure for your vehicle.

2007-2011 Models:

- Select the Driver Center Support Bracket (**DCS**). Bolt the Support Bracket to the back of the Driver Center Mounting Bracket with (1) M8X1.25-30mm Hex Bolt, (2) M8 Large Flat Washers, (1) M8 Lock Washer and (1) M8 Hex Nut, (**Figs 5 & 6**). Do not fully tighten hardware at this time.
- Make sure the Center Mounting Bracket is in the proper position, straight and level. Tighten the M10 Bolt Plate hardware first. Firmly hold the Support Bracket up in place against the back of the body panel and tighten the M8 hardware.
- Mark the mounting hole location onto the back of the body panel, (**Fig 6**). Remove the Center Bracket.
- Drill a 7/16" hole through the center of the marked location. **IMPORTANT!** Any cutting or drilling tool may break or shatter. Government regulations require safety glasses & equipment at all times when cutting or drilling.
- Assemble the Insert Installation Tool as pictured in **Fig 7A**. Firmly hold handle on the tool and push the M8 Rivet

Nut into the drilled hole. **NOTE:** Select 8mm hole on threaded tool, (**Fig 7B**). If the M8 Rivet Nut is too tight to install, (push into hole), by hand, lightly tap into position with small hammer. Do not damage the Insert.

- Once M8 Rivet Nut into drilled hole, hold the Rivet Nut in place with the handle and tighten the M8 Hex Bolt with a wrench to compress/expand the Rivet Nut in the body panel, (**Fig 8A**). Once the Rivet Nut is fully compressed, remove the bolt and tool from the Rivet Nut. **WARNING:** Do not over tighten hex bolt or Rivet Nut may be damaged.
- Reinstall the Center Mounting Bracket and Support Bracket, (**Fig 8B**). Bolt the tab on the Support Bracket to the Rivet Nut with (1) M8X1.25-30mm Hex Bolt, (1) M8 Lock Washer and (1) M8 Large Flat Washer, (**Fig 8C**). Do not fully tighten hardware at this time.

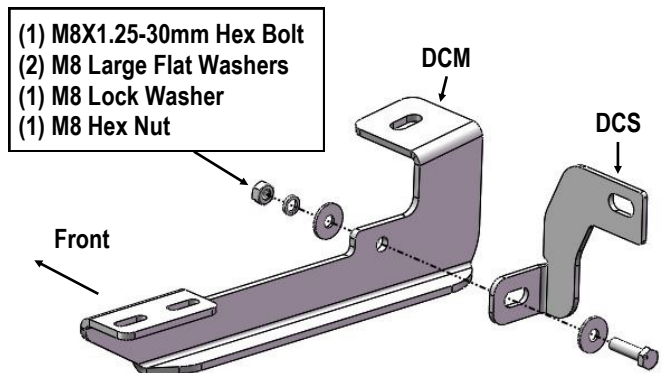

(Fig 5) Driver Side Center Bracket Assembly

iBoard®

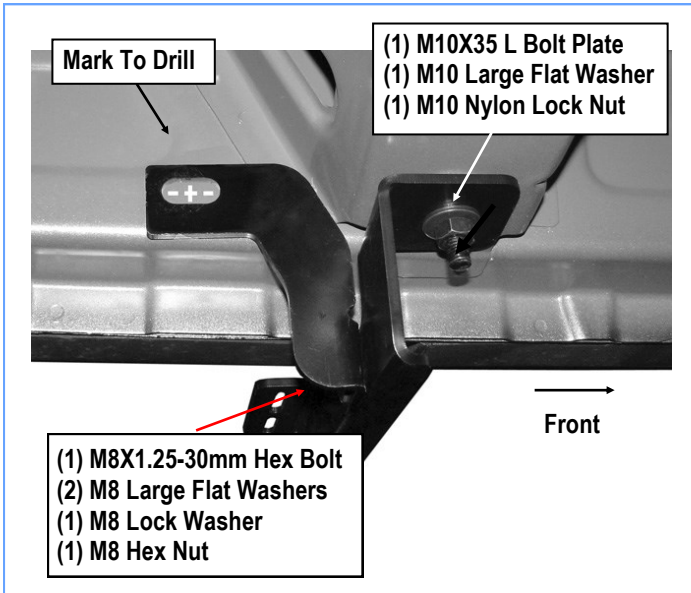

(Fig 6) Driver Side Center Bracket Installation



(Fig 7A) Assemble the Insert Installation Tool

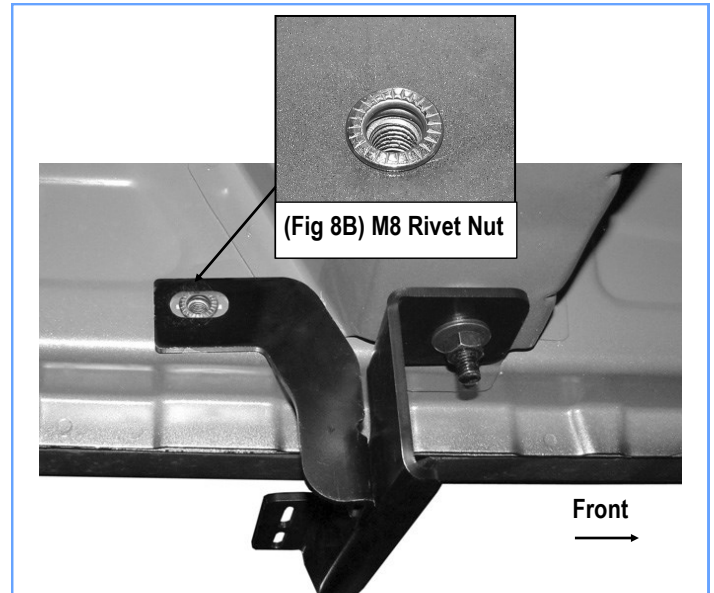

(Fig 8A) Driver Side Center Bracket Installation (2007-11)

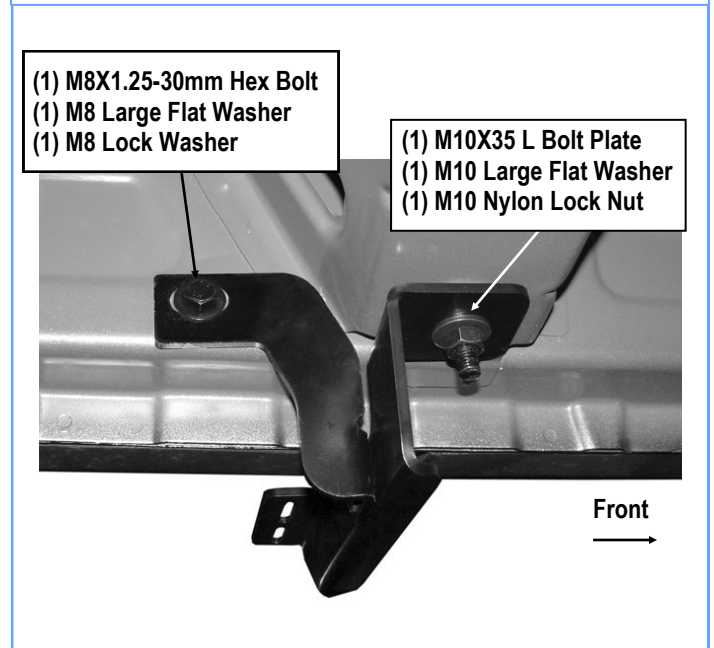

(Fig 8C) Driver Side Center Bracket Installed
(For 2007-2011 Models)

iBoard®

2012-2013 Models:

- a. Select (1) M8X30 Bolt Plate and (1) M8 Plastic Washer, **(Fig 9A)**. Partially thread the M8 Plastic Washer onto the M8X30 Bolt Plate. **IMPORTANT:** The M8 Plastic Washer is designed to prevent the M8X30 Bolt Plate from falling into the body panel and to aid in installing the Bracket.
- b. Insert the M8X30 Bolt Plate into the hole in the back of the body panel with Plastic Washer on outside, **(Fig 9B)**. Hold the threaded end of the M8X30 Bolt Plate and thread the Plastic Washer down tight against the panel.
- c. Select the driver side Center Support Bracket. Secure the Support Bracket to the M8X30 Bolt Plate with (1) M8 Large Flat Washer, (1) M8 Lock Washer and (1) M8 Hex Nut, **(Fig 10)**.
- d. Bolt the Support Bracket to the back of the Center Mounting Bracket with (1) M8X1.25-30mm Hex Bolt, (2) M8 Large Flat Washers, (1) M8 Lock Washer and (1) M8 Hex Nut, **(Fig 5)**. Do not fully tighten hardware at this time.

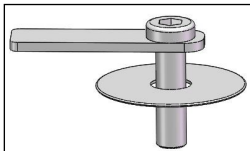

(Fig 9A) M8X30 Bolt Plate with M8 Plastic Washer

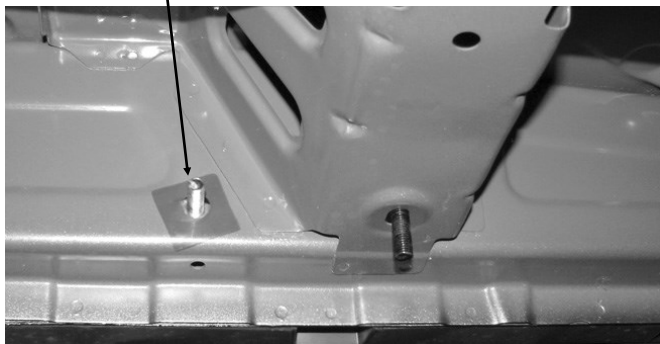

→
Front

(Fig 9B) Driver Side Center Mounting Location (2012-2013 Models)

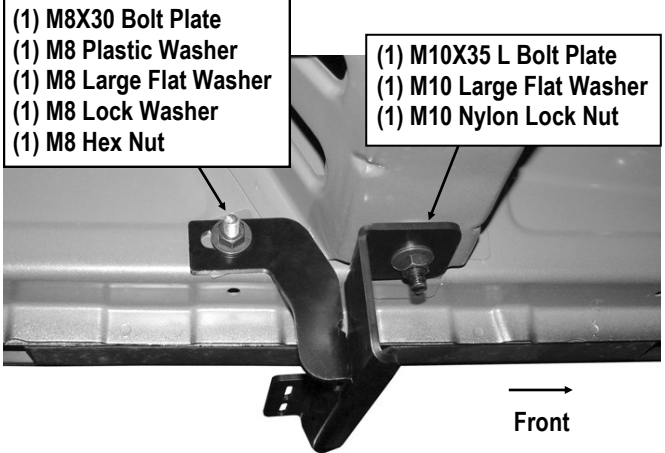

(Fig 10) Driver Side Center Brackets Installed (2012-2013 Models)

STEP 5

Once center Brackets have been installed, hold plastic cover up in position and mark location of Brackets onto cover. Carefully cut out location with knife or hacksaw blade, **(Fig 11)**. Cut the cover to first clear the Center Brackets.

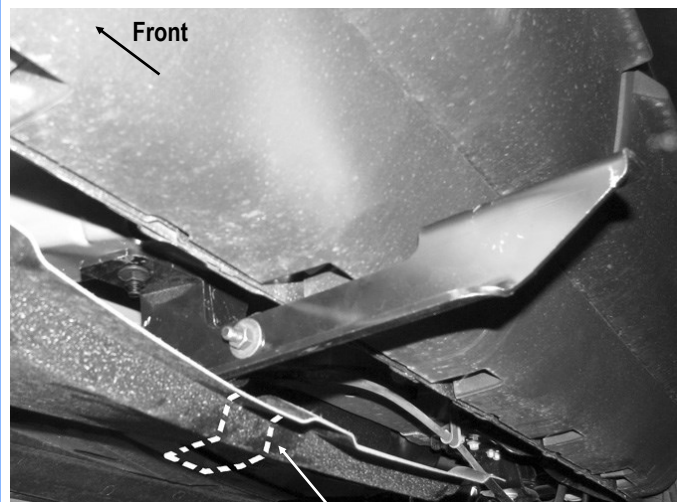

(Fig 11) Hold Plastic Cover Up In Position And Mark Location Of Brackets Onto Cover

iBoard®

STEP 6

Hold the front of the plastic cover up in position and trace the location of the inner M10X35 Long Bolt Plate, (see Step 2), onto the inside of the cover. Cut a hole in the center of the marked section to clear the Bolt Plate. Hold the Cover up in place over the Bolt Plate to check location, (Fig 12).

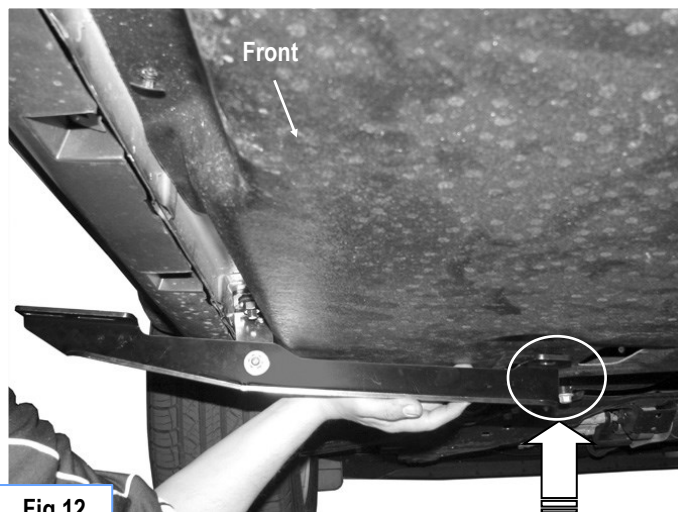
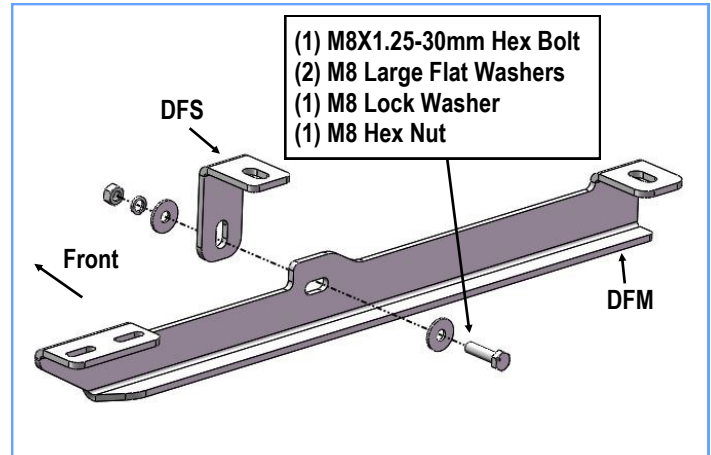

Fig 12

STEP 7

Attach the driver side Front Mounting Bracket to the back of the Support Bracket with (1) M8X1.25-30mm Hex Bolt, (2) M8 Large Flat Washers, (1) M8 Lock Washer and (1) M8 Hex Nut, (Fig 13). Do not fully tighten hardware at this time. Hold the inner end of the Mounting Bracket up against the plastic cover and over the Bolt Plate. Trace the outline of the Bracket onto the cover, (Fig 14A).

Remove the Mounting Bracket and cover. Cut out the traced area to clear the inner end of the front Bracket, (Fig 14B). **IMPORTANT:** Do not cut off the mounting area for the clip. Only remove material required to clear the Bracket. Check the fit often. Reinstall the plastic cover over the Bolt Plate but leave loose at this time. Do not fully reattach the cover until Brackets are fully tightened.



(Fig 13) Driver Side Front Bracket Assembly

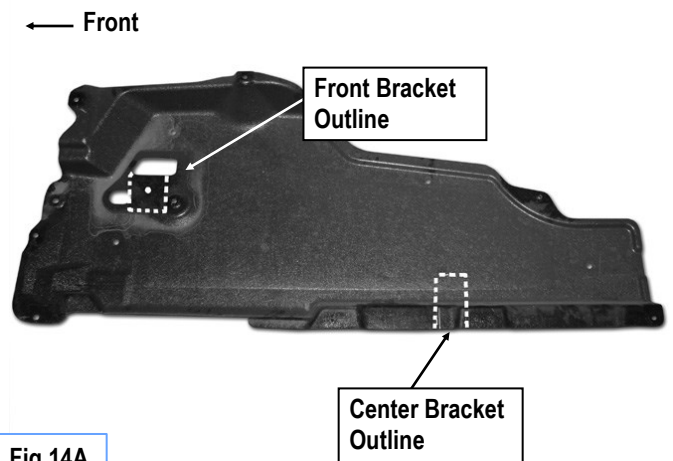

Fig 14A

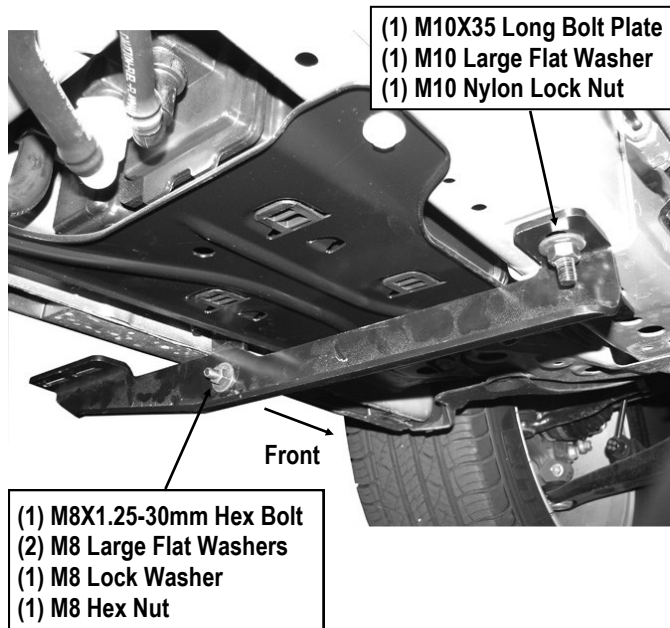

Fig 14B

iBoard®

STEP 8

Reinstall the Front Bracket as described in **Step 2**. Attach the inner end of the front Mounting Bracket to the M10X35 Long Bolt Plate with (1) M10 Large Flat Washer and (1) M10 Nylon Lock Nut, (**Fig 15**). Trim the plastic cover to clear the Bracket as necessary. Do not fully tighten hardware at this time.



(Fig 15) Driver Side Front Brackets Installation

STEP 9

Move to the driver side rear mounting location. Locate the (2) holes in the inner floor panel, (**Fig 16**). Insert (1) M10X35 Short Bolt Plate into the large hole and out the smaller, outer hole, (**Fig 17**). **NOTE:** Hold the driver side Rear Mounting Bracket in position to determine the correct mounting holes to use.

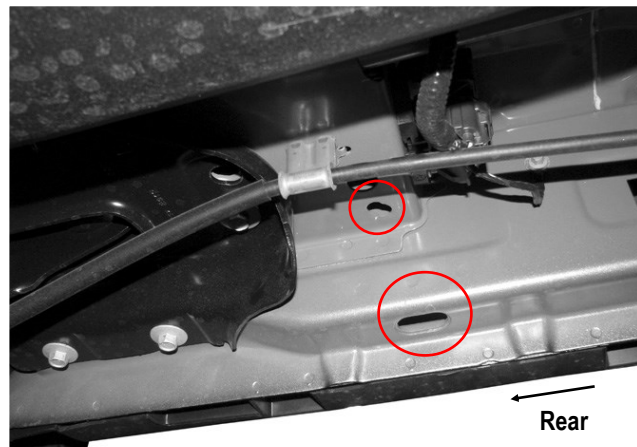

(Fig 16) Driver Side Rear Mounting Location Pictured

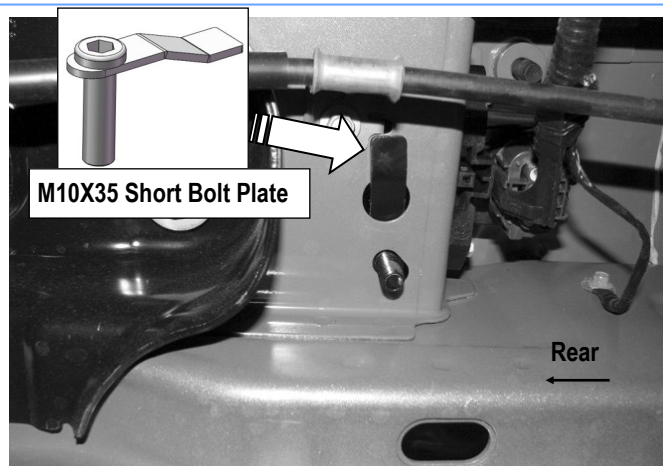

(Fig 17) Insert (1) M10X35 Short Bolt Plate (on Drivers Side Rear Mounting Location)

STEP 10

Next, locate the oval hole next to the pinch weld, (**Fig 16**). Insert (1) M10X30 Bolt Plate into the factory hole in the outer frame channel as described in **Step 1**, (**Fig 18**).

Select the driver side rear Support Bracket. Attach the Driver Rear Support Bracket (**DRS**) to the M10X30 Bolt Plate with (1) M10 Large Flat Washer and (1) M10 Nylon Lock Nut, (**Fig 19**). Select the Driver Rear Mounting Bracket (**DRM**). Attach the Bracket to the M10X35 Short Bolt Plate with (1) M10 Large Flat Washer and (1) M10 Nylon Lock Nut, (**Fig 19**). Do not fully tighten hardware at this time.

iBoard®

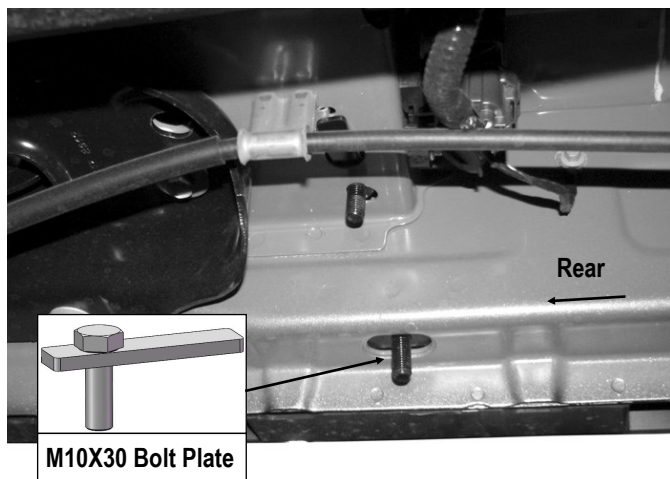

(Fig 18) Insert (1) M10X30 Bolt Plate

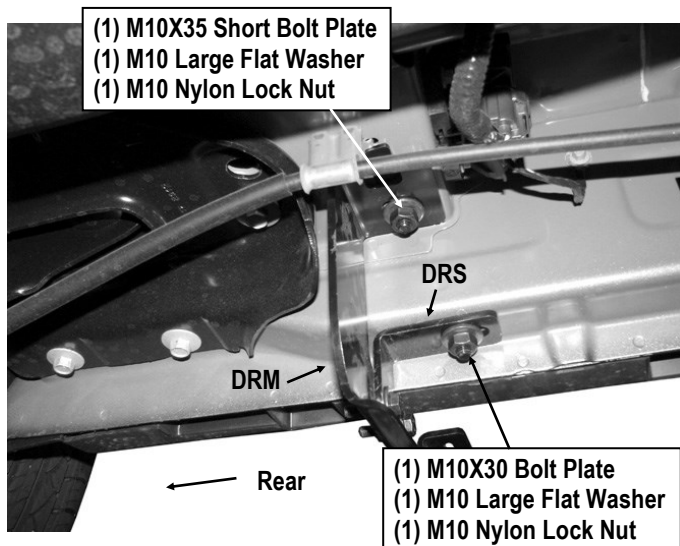

(Fig 19) Driver Side Rear Bracket Installation

STEP 11

Bolt the Mounting Bracket to the back of the Support Bracket with (2) M8X1.25-30mm Hex Bolts, (4) M8 Large Flat Washers, (2) M8 Lock Washers and (2) M8 Hex Nuts, (Figs 19 & 20). Do not fully tighten hardware at this time.

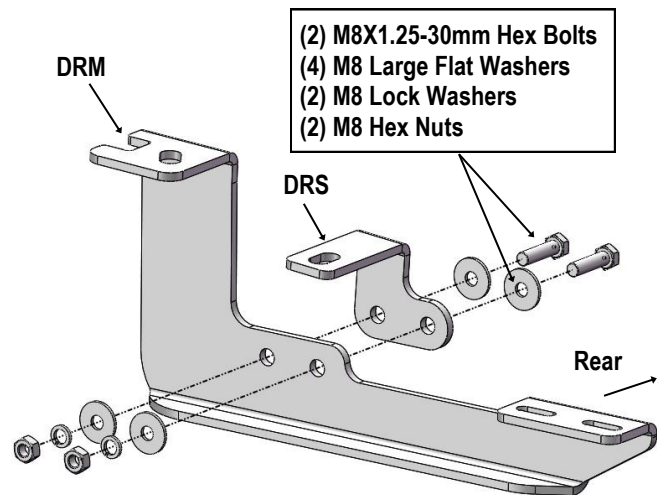

(Fig 20) Driver Side Rear Mounting Bracket Assembly

STEP 12

Once all (3) mounting brackets are installed, then proceed to the Step Bar installation. According to the style of Step Bar proceed to the correct installation STEPS.

Note: Aluminum Step Bar refer to STEP 13; Stainless Steel Step Bar skip to STEP 14.

STEP 13

Aluminum Step Bar Installation:

Select a **Aluminum Step Bar**. Slip (3) M6x1-20mm Square Head Bolts into each bottom channel (Fig 21). Carefully position the Step Bar onto the (3) Mounting Brackets.

IMPORTANT: Do not slide the Step Bar on the Brackets or the bottom surface of the board will be damaged. Attach the Step Bar to each Mounting Brackets with (2) M6x1-20mm Square Head Bolts, (2) M6 Large Flat Washers and (2) M6 Nylon Lock Nuts, (Fig 22). Do not fully tighten at this time.

Level and adjust the Step Bar and fully tighten all hardware.

Repeat **Steps 1-13** for the other side Step Bar installation. **The installation is completed!!!**

iBoard®



(Fig 21) Slip M6X1-20mm Square Head Bolts Into The Bottom Channels

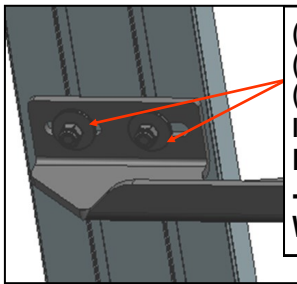

(2) M6X1-20mm Square Head Bolts
(2) M6 Large Flat Washers
(2) M6X1 Nylon Lock Nuts
IMPORTANT: TORQUE FOR 6MM FASTNERS MUST LESS THAN 6-7 FT-LBS OR THE FASTNERS WILL BE DAMAGED!

(Fig 22) Running Board Installed Onto Mounting Bracket



(Fig 23) Slide & line up the U-Slider with the installed mounting brackets along bottom channel

(2) M6X1-20mm Hex Bolts
(2) M6 Large Flat Washers
(2) M6 Lock Washers
IMPORTANT: TORQUE FOR 6MM FASTNERS MUST LESS THAN 6-7 FT-LBS OR THE FASTNERS WILL BE DAMAGED!

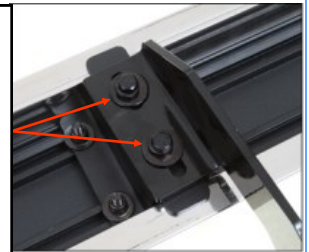

(Fig 24) Step Bar Installed on Bracket Installed (Example)

STEP 14

Stainless Steel Step Bar Installation:

Select a **Stainless Steel Step Bar** (with the U-Sliders installed on the Bar). Loose the U-Sliders, reposition the U-Sliders onto the board according to the (3) Installed Mounting Brackets location, (Fig 23). Re-secure the U-Sliders on the Step Bar. Attach the Step Bar to the installed Mounting Brackets with (6) M6X1-20mm Hex Bolts, (6) M6 Large Flat Washers & (6) M6 Lock Washers, (Fig 24). Do not fully tighten hardware at this time.

Level and adjust the Step Bar and fully tighten all hardware. Repeat **Steps 1-12 and 14** for the other side Step Bar installation. **The installation is completed!!!**

Attention

Do periodic inspections to the installation to make sure that all hardware is secure and tight.

In order to protect your bars/boards, please use only mild soap/non-abrasive products for cleaning.