

iBoard®

iBoard® by APS

PART#: IB-R046

READ INSTRUCTIONS CAREFULLY BEFORE STARTING INSTALLATION. REMOVE CONTENTS FROM BOX AND VERIFY ALL PARTS ARE PRESENT. ASSISTANCE IS RECOMMENDED.

*ROCKER PANEL MOUNT
*DRILLING IS REQUIRED

Fastener Size	Tightening Torque (ft-lbs)	Required
6mm	6-7	√
8mm	16-18	√
10mm	31-32	X
12mm	56-58	X
14mm	92-94	X

Item	QTY	Description	Item	QTY	Description
1#	8	Mounting Brackets	5#	16	ST6.3-25mm Hex Flange Self Tapping Screws
2#	8	M8X1.25-20mm Hex Bolts	6#	16	M6X1-20mm Square Head Bolts
3#	16	M8 Large Flat Washers	7#	16	M6 Large Flat Washers
4#	8	M8 Nylon Lock Nuts	8#	16	M6 Nylon Lock Nuts

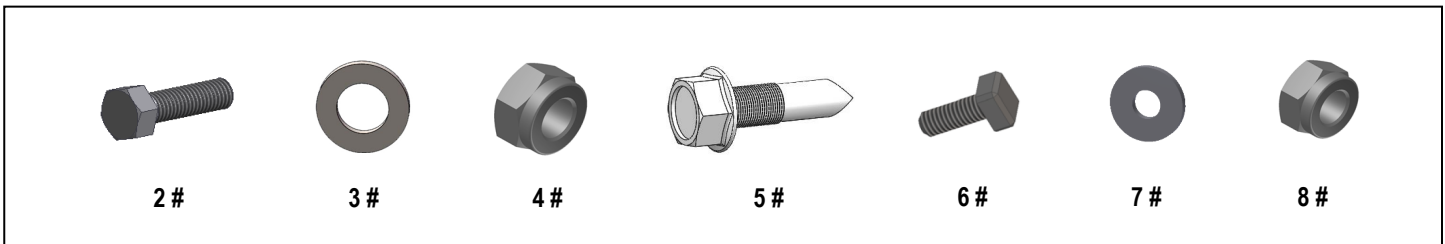

iBoard®

Driver

Front



Passenger

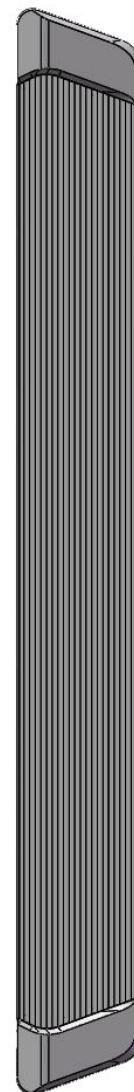
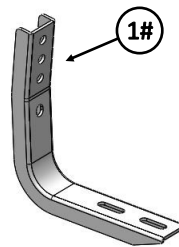
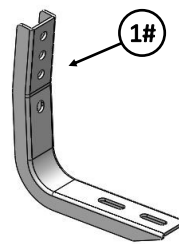
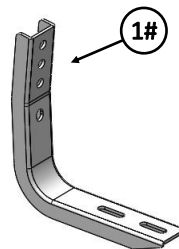
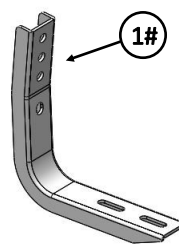
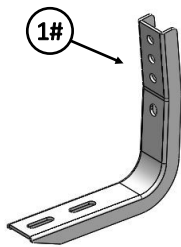
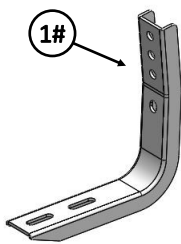
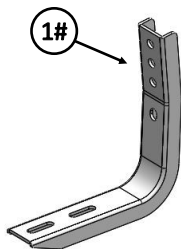
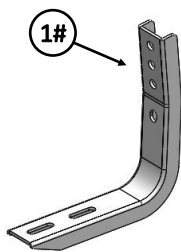

iBoard®

STEP 1

Starting on the Driver side of the vehicle. Attach (1) Mounting Bracket to the rocker panel with (2) ST6.3-25mm Hex Flange Self Tapping Screws per bracket (**Fig 1**). Don't fully tighten at this time.

Note: (8) Mounting Brackets Are Universal.

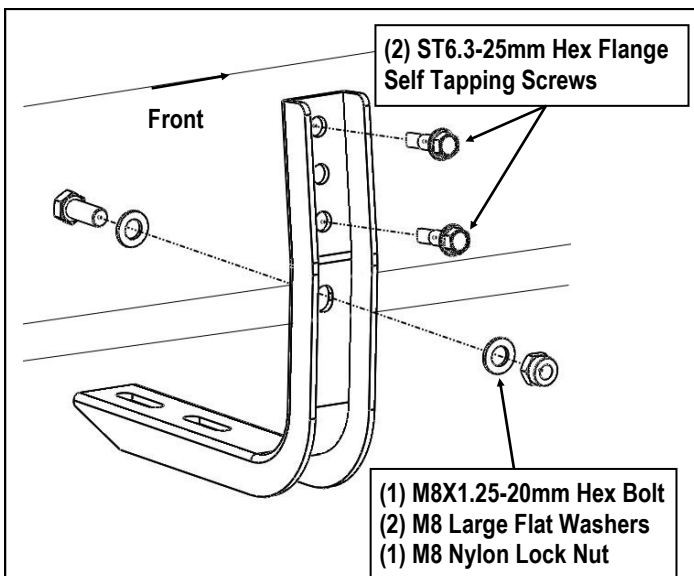

(Fig 1) Driver Side Mounting Bracket Installation Exemplified

STEP 2

Use the Mounting Bracket as template, mark and drill (4) 8mm holes in pinch weld. If necessary, remove the brackets from the rocker panel for drilling (**Fig 2**). **Note: The dimensions on Fig 2 for reference only. It may be varied on some models.**

STEP 3

Attach the Mounting Bracket onto the drilled holes on pinch weld with (1) M8X1.25-20mm Hex Bolt, (2) M8 Large Flat Washers and (1) M8 Nylon Lock Nut, (**Fig 1**). Don't fully tighten at this time.

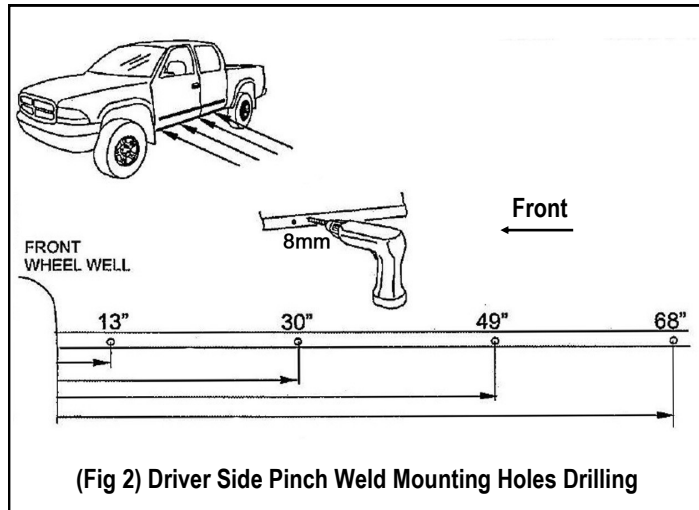

STEP 4

Select a Running Board. Slip (4) M6x1-20mm Square Head Bolts into each bottom channel (**Fig 3**). Carefully position the Running Board onto the (4) Mounting Brackets.

IMPORTANT: Do not slide the Running Board on the Brackets or the bottom surface of the board will be damaged. Attach the Running Board to each Mounting Bracket with (2) M6x1-20mm Square Head Bolts, (2) M6 Large Flat Washers and (2) M6 Nylon Lock Nuts (**Fig 4**). Do not fully tighten at this time.

M6X1-20mm Square Head Bolts

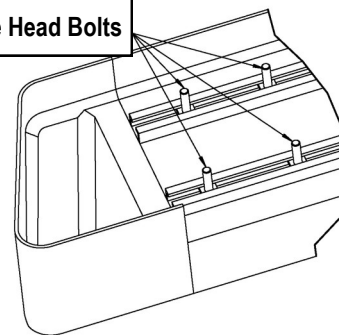

(Fig 3) Slip M6X1-20mm Square Head Bolts Into The Bottom Channels

iBoard®

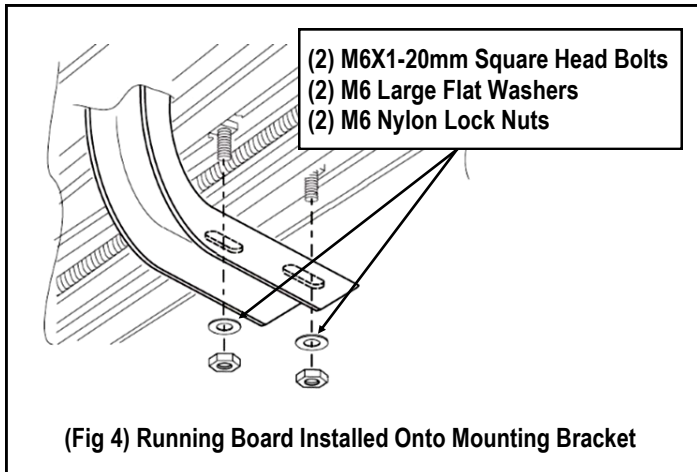

STEP 5

Level and adjust the Running Board and fully tighten all hardware.

Important: Please follow the recommended Tightening Torques shown in the table on page 1. Don't over tighten, or the nuts/bolts will be damaged.

STEP 6

Repeat **Steps 1-5** for the other side Running Board installation. The installation is completed.

Attention

Do periodic inspections to the installation to make sure that all hardware is secure and tight.

In order to protect your bars/boards, please use only mild soap/non-abrasive products for cleaning.