

# iBoard®

## iBoard® by APS

PART#: IB-R403

READ INSTRUCTIONS CAREFULLY BEFORE STARTING INSTALLATION. REMOVE CONTENTS FROM BOX AND VERIFY ALL PARTS ARE PRESENT. ASSISTANCE IS RECOMMENDED.

\*ROCKER PANEL MOUNT  
\*DRILLING IS REQUIRED

Fastener Size	Tightening Torque (ft-lbs)	Required
6mm	6-7	√
8mm	16-18	√
10mm	31-32	√
12mm	56-58	X
14mm	92-94	X

### PART LIST

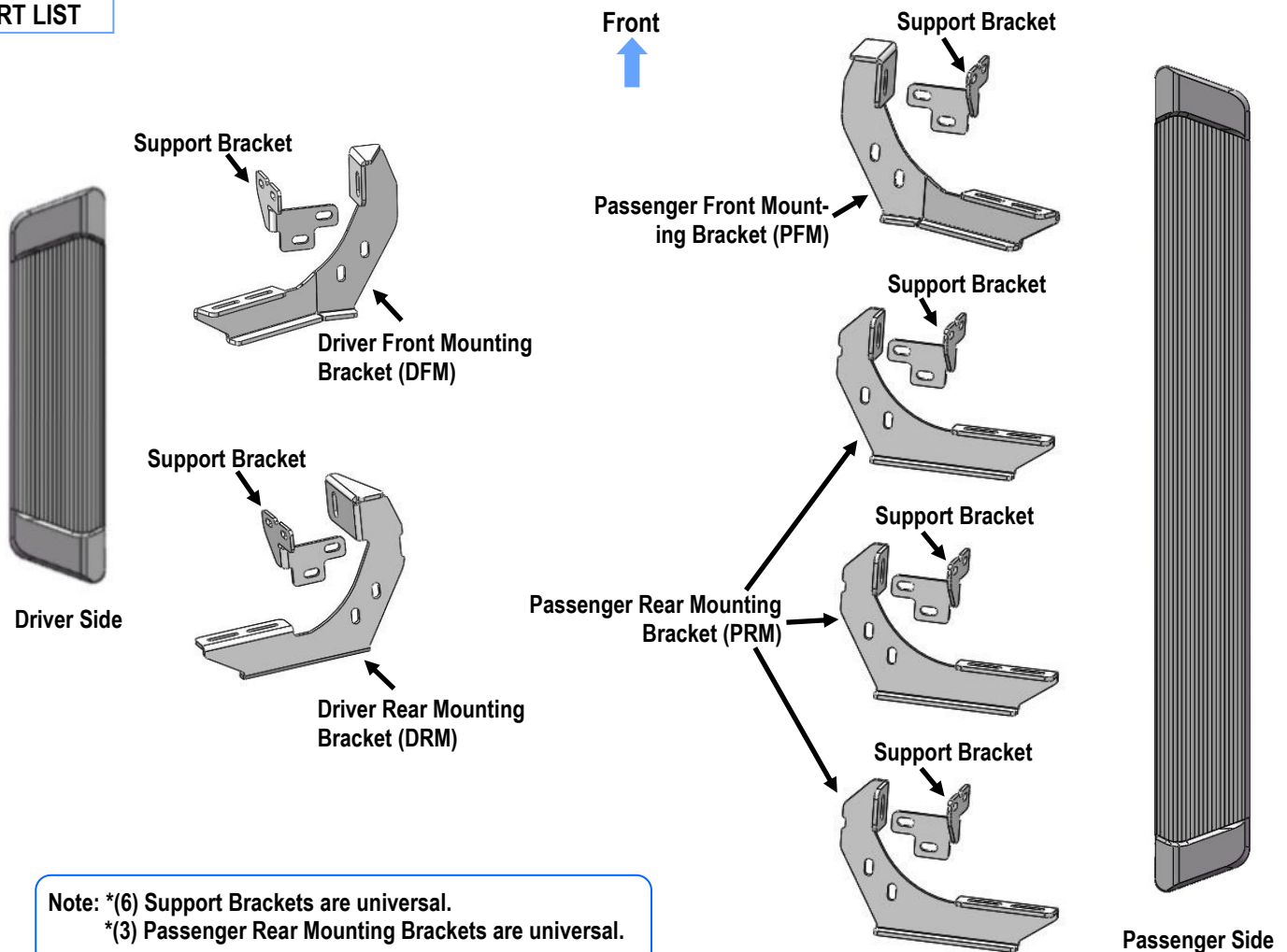

Note: \*(6) Support Brackets are universal.  
\*(3) Passenger Rear Mounting Brackets are universal.

Customer Support: [info@iboardauto.com](mailto:info@iboardauto.com)

# iBoard®



## STEP 1

Starting installation from the passenger side front of the vehicle, locate the factory hole on the inner body panel from the front tire opening, (**Figs 1 & 2**). Remove the rubber plug.

**NOTE:** Mounting locations may be covered with heavy undercoating. Refer to instructions to find all mounting locations.

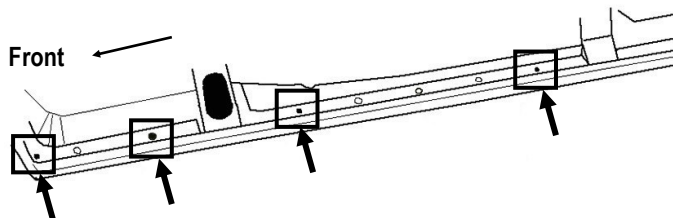

(Fig 1) Passenger Side Mounting Locations

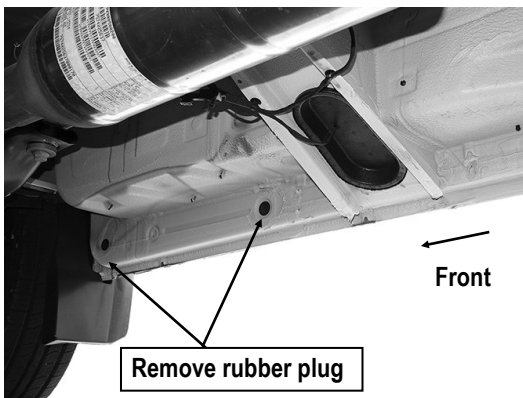

(Fig 2) Passenger Side Front & 2nd Mounting Location

## STEP 2

Select (1) M10 Bolt Plate and (1) M10 Plastic Washer. Insert the M10 Bolt Plate into the hole and thread (1) M10 Plastic Washer onto the Bolt Plate to hold it in place, (**Fig 3**).

**IMPORTANT:** The Plastic Washer is designed to hold the Bolt Plate in place during the Bracket installation.

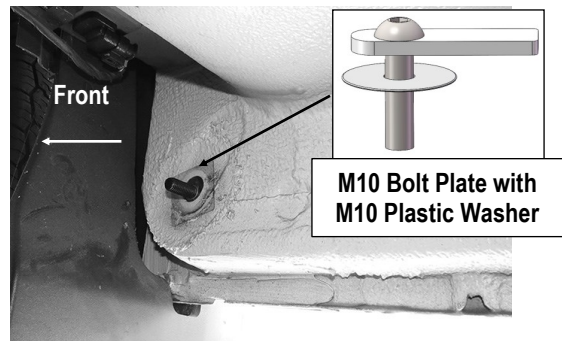

(Fig 3) Insert M10 Bolt Plate

## STEP 3

Select the Passenger Front Mounting Bracket (**PFM**). Attach the Bracket to the installed M10 Bolt Plate with (1) M10 Flat Washer, (1) M10 Lock Washer and (1) M10 Hex Nut, (**Fig 4**). Do not fully tighten hardware at this time.

# iBoard®

## STEP 5

Move to the passenger side 2nd & 3rd & rear mounting locations, (Figs 2 & 6). Repeat **Steps 2—4** to install (3) Passenger Rear Mounting Bracket (PRM) and assemble (3) Support Brackets, (Figs 7-8).

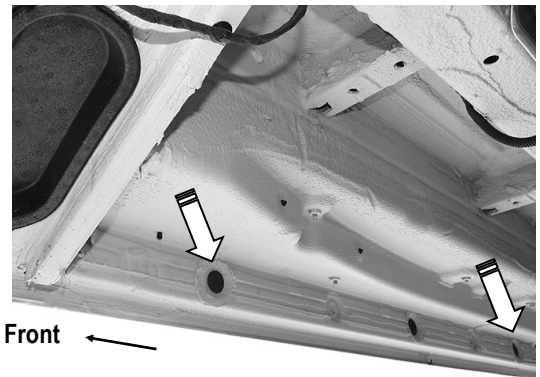

(Fig 6) Passenger Side 3rd & Rear Mounting Locations

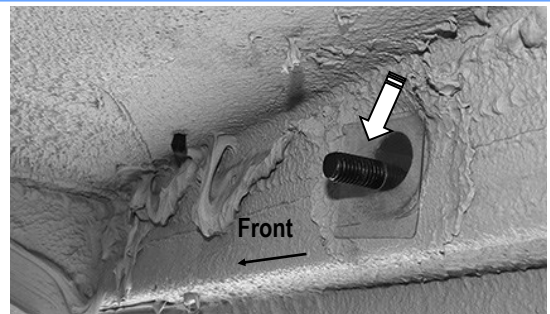

(Fig 7) Inserted The Bolt Plate Into The 3rd Mounting Location

- (2) M8X1.25-30mm Hex Bolts
- (4) M8 Large Flat Washers
- (2) M8 Lock Washers
- (2) M8 Hex Nuts

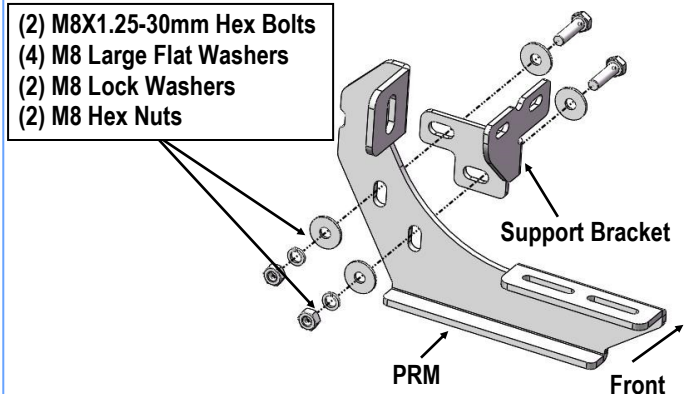

(Fig 8) Passenger 2nd & 3rd & Rear Mounting Bracket and the Support Bracket Assembly

- (1) M10 Flat Washer
- (1) M10 Lock Washer
- (1) M10 Hex Nut

- (1) M10 Bolt Plate
- (1) M10 Plastic Washer

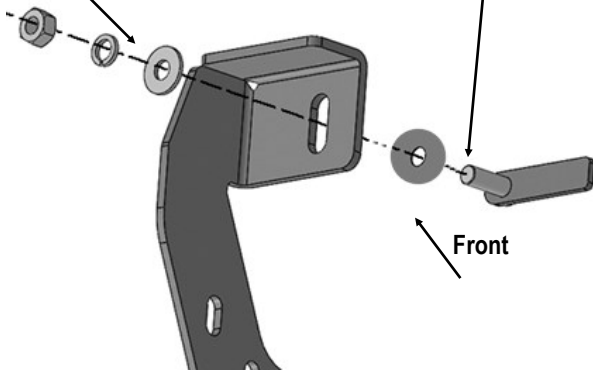

(Fig 4) Passenger Front Mounting Bracket Installation

## STEP 4

Next, select (1) Support Bracket. Attach the Support Bracket to the Passenger Front Mounting Bracket (PFM) with (2) M8X1.25-30mm Hex Bolts, (4) M8 Large Flat Washers, (2) M8 Lock washers and (2) M8 Hex Nuts, (Fig 5). Attach the mounting flange on the Support Bracket to the **outside** of the pinch weld. Do not fully tighten hardware at this time.

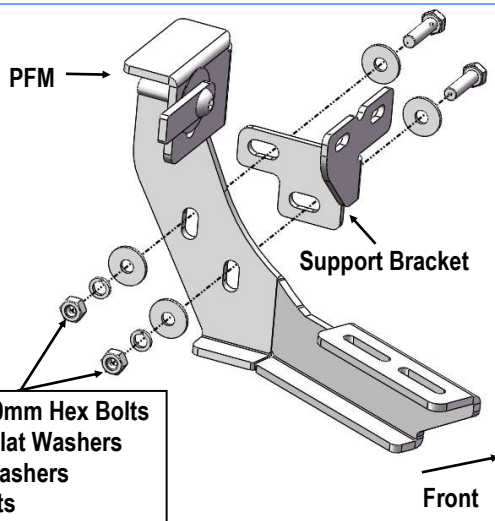

- (2) M8X1.25-30mm Hex Bolts
- (4) M8 Large Flat Washers
- (2) M8 Lock Washers
- (2) M8 Hex Nuts

(Fig 5) Passenger Front Mounting Bracket and the Support Bracket Assembly

# iBoard®

## STEP 6

Select the long passenger side Running Board. Place the Running Board on top of the (4) Brackets. Level and adjust the Running Board and fully tighten the Bracket to vehicle hardware only. Temporarily remove the Running Board.

## STEP 7

Make sure the Brackets are level to the vehicle. Line up the slots on each Support Bracket with the outside of the pinch weld. Mark the location of the slots onto the pinch weld, (Fig 9). And then drill through holes on the pinch weld.

**IMPORTANT:** Adjust Support Brackets and/or Mounting Brackets, do not drill too close to the bottom edge of the pinch weld. Once the Running Board and Brackets are properly adjusted and slot locations marked, remove the Running Board and Support Brackets. Use a 5/16" drill bit to drill the (2) holes through the pinch weld for each Support Bracket.

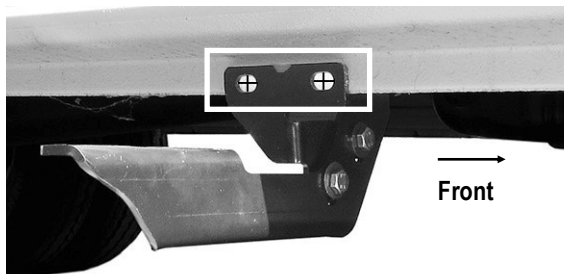

(Fig 9) Mark the Slot Locations of Each Support Bracket Onto Pinch Weld Before Drilling

## STEP 8

Attach each Support Bracket to the outside of the pinch weld with (2) M6X1-30mm Hex Bolts, (4) M6 Flat Washers, (2) M6 Lock Washers and (2) M6 Hex Nuts, (Fig 10). Repeat this Step to attach the remaining (3) Passenger Support Brackets. Tighten the hardware attaching the Support Brackets to the vehicle only.

(2) M6X1-30mm Hex Bolts  
(4) M6 Flat Washers  
(2) M6 Lock Washers  
(2) M6 Hex Nuts

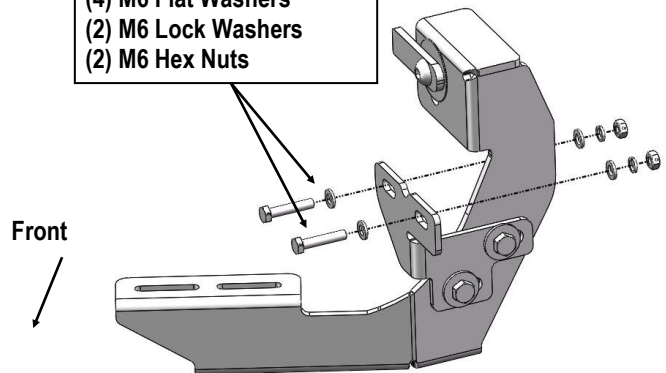

(Fig 10) Attach Support Bracket To Pinch Weld (Passenger Front Mounting Bracket)

## STEP 9

Select the Passenger Side Running Board. Slip (4) M6x1-20mm Square Head Bolts into each bottom channel (Fig 11). Carefully position the Running Board onto the (4) Mounting Brackets.

**IMPORTANT:** Do not slide the Running Board on the Brackets or the bottom surface of the board will be damaged. Attach the Running Board to each Mounting Bracket with (2) M6x1-20mm Square Head Bolts, (2) M6 Large Flat Washers and (2) M6 Nylon Lock Nuts (Fig 12). Do not fully tighten hardware at this time.

M6X1-20mm Square Head Bolts

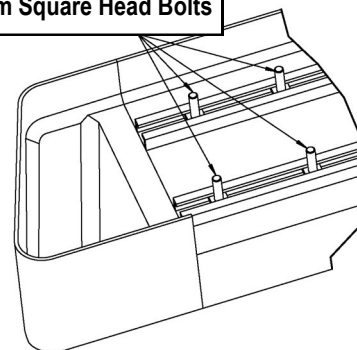

(Fig 11) Slip M6X1-20mm Square Head Bolts Into The Bottom Channels

# iBoard®

- (2) M6X1-20mm Square Head Bolts
- (2) M6 Large Flat Washers
- (2) M6 Nylon Lock Nuts

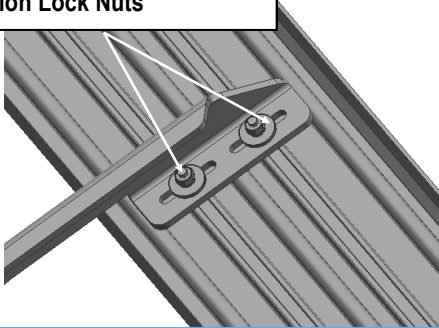

(Fig 12) Running Board Installed Onto Mounting Bracket (Example)

## STEP 10

Move to the Driver side of the vehicle (Fig 13). If equipped, remove the cover coating and the rubber plugs from the mounting locations.

Repeat **Steps 2-4** to assembly and install the Driver Side Front & Rear Mounting Brackets and Support Brackets, (Figs 14 - 16). Do not fully tighten hardware at this time.

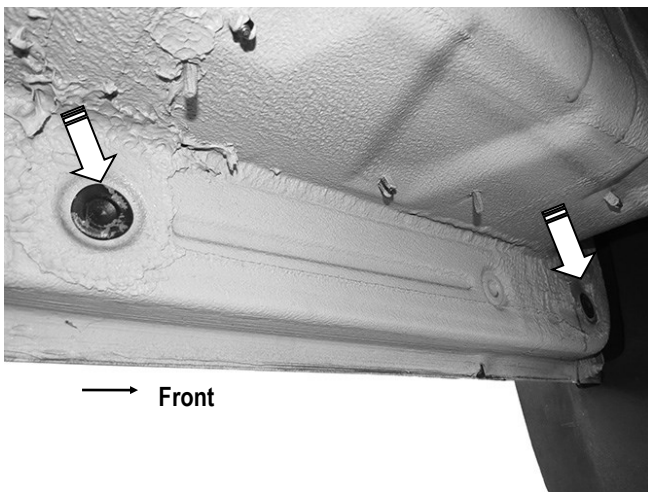

(Fig 13) Driver Side Mounting Locations

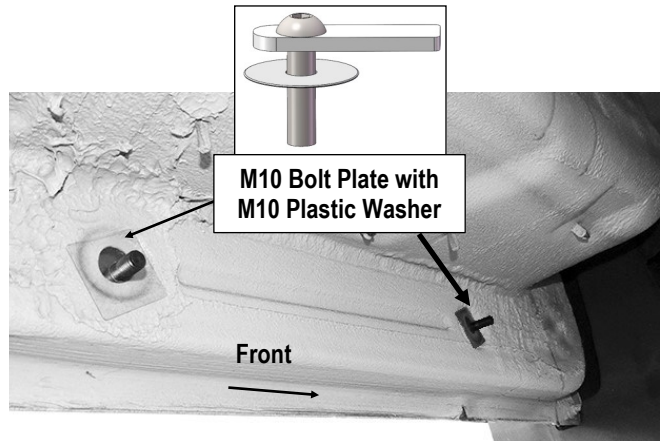

(Fig 14) Bolt Plates with Plastic Washers Inserted on Driver Front & Rear Mounting Locations

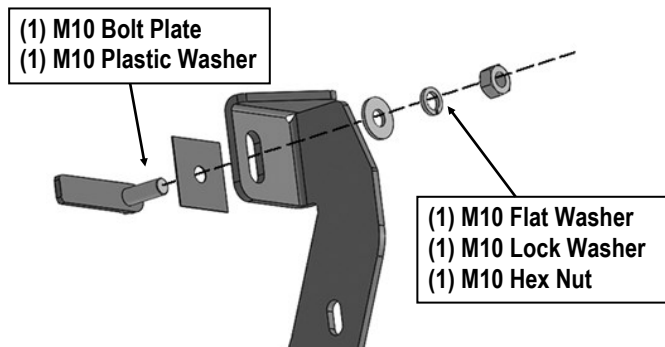

(Fig 15) Driver Front Mounting Bracket Installation

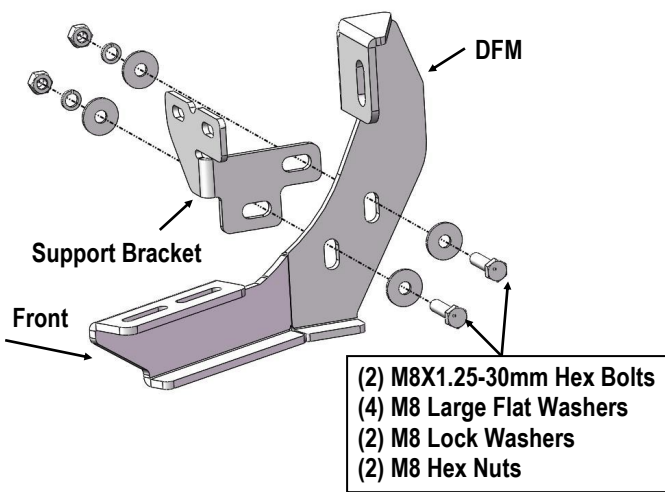

(Fig 16) Support Bracket & Driver Front Mounting Bracket Assembly

# iBoard®

## STEP 11

Select the Driver Side Running Board. Repeat **Steps 6—9** to drill the pinch weld to attach the Support Brackets and Running Board.

## STEP 12

Level and adjust the Running Board and fully tighten all hardware. The installation is completed.

### **Attention**

**Do periodic inspections to the installation to make sure that all hardware is secure and tight.**

**In order to protect your bars/boards, please use only mild soap/non-abrasive products for cleaning.**