

# iBoard®

## iBoard® by APS

PART#: IB-R402

READ INSTRUCTIONS CAREFULLY BEFORE STARTING INSTALLATION. REMOVE CONTENTS FROM BOX AND VERIFY ALL PARTS ARE PRESENT. ASSISTANCE IS RECOMMENDED.

\*ROCKER PANEL MOUNT  
\*DRILLING IS REQUIRED

Fastener Size	Tightening Torque (ft-lbs)	Required
6mm	6-7	√
8mm	16-18	√
10mm	31-32	X
12mm	56-58	X
14mm	92-94	X

### PART LIST



Driver Side

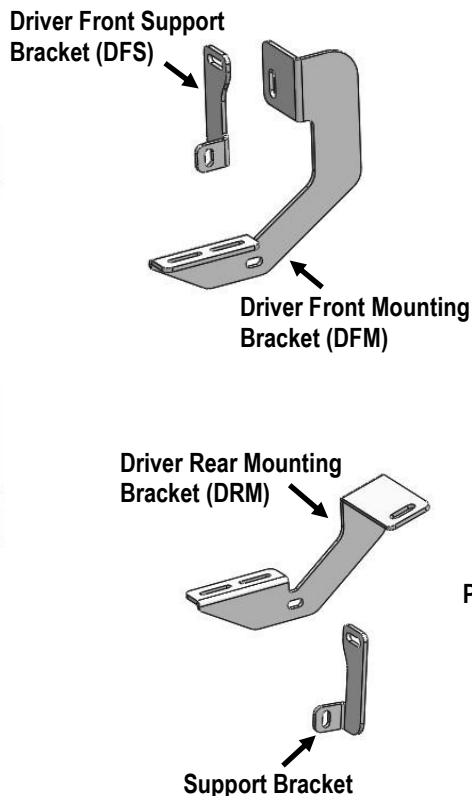

Front

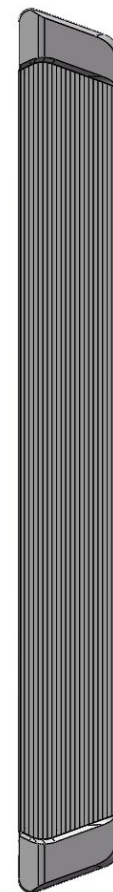
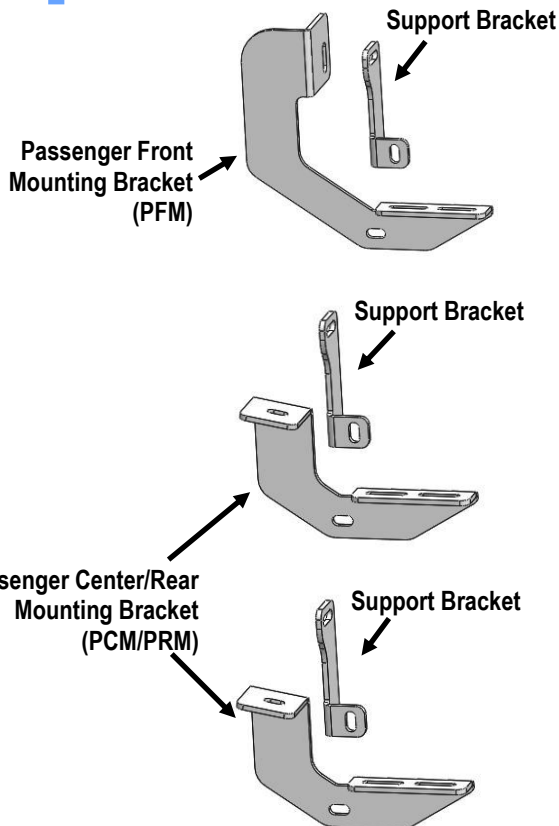

Passenger Side

Note: \*(4) Support Brackets are universal.  
\*Passenger Center & Rear Mounting Brackets are universal.

Customer Support: [info@iboardauto.com](mailto:info@iboardauto.com)

# iBoard®

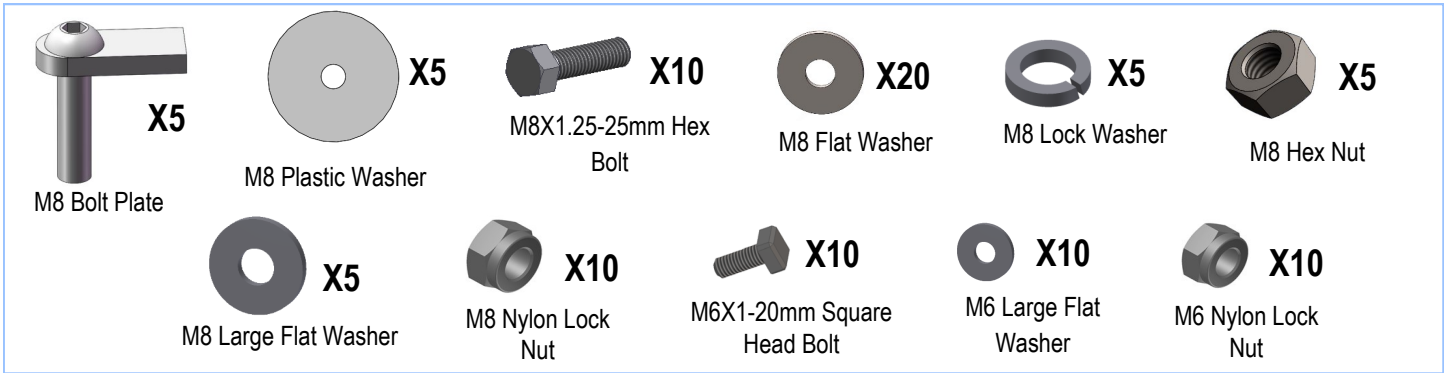

## STEP 1

Starting installation from the driver side front of the vehicle. Locate the factory hole in the side of the inner body panel, (**Fig 1A & 1B**).

**IMPORTANT:** Hole may be covered with rubber plug, sealing tape and/or heavy undercoating. Remove excess undercoating from all mounting locations so that Brackets will install flat against body panel and pinch weld.

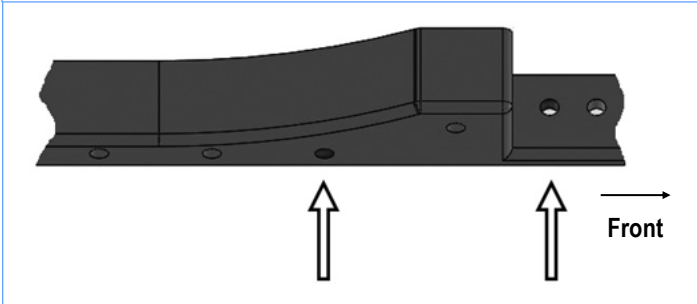

(Fig 1A) Driver Side Front & Rear Mounting Bracket Location



(Fig 1B) Driver Side Front Mounting Bracket Location

## STEP 2

Select (1) M8 Bolt Plate and (1) M8 Plastic Washer. Thread the M8 Plastic Washer part way onto the M8 Bolt Plate. Insert the M8 Bolt Plate into the hole and tighten the M8 Plastic Washer against the body panel, (**Fig 1B**). **IMPORTANT:** The M8 Plastic Washer is designed to prevent the M8 Bolt Plate from falling into the body panel and to aid in Bracket installation.

## STEP 3

Select the Driver Front Mounting Bracket (**DFM**) and the Driver Front Support Bracket (**DFS**). Attach the Support Bracket to the front of the Mounting Bracket with (1) M8X1.25-25mm Hex Bolt, (2) M8 Flat Washers and (1) M8 Nylon Lock Nut, (**Fig 2**). Do not fully tighten hardware at this time.

**Note:** Driver Front Support Bracket (**DFS**) is different with (4) Support Brackets.

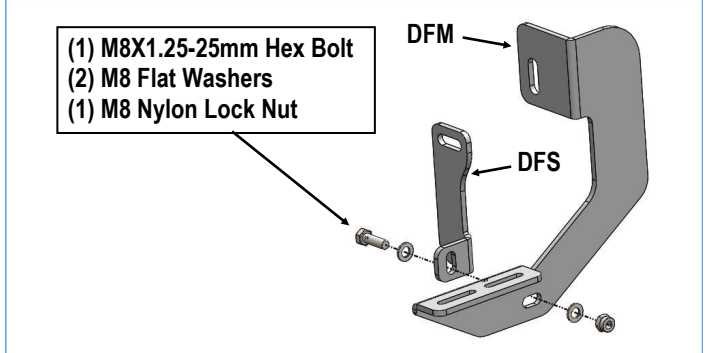

(Fig 2) Driver Front Mounting Bracket (DFM) and the Driver Front Support Bracket (DFS) Assembly

# iBoard®

## STEP 4

Attach the Driver Front Mounting Bracket (DFM) to the M8 Bolt Plate with (1) M8 Large Flat Washer, (1) M8 Lock Washer and (1) M8 Hex Nut, (Fig 3). Do not fully tighten hardware at this time.

Line up the top of the Support Bracket with the outside of the pinch weld.

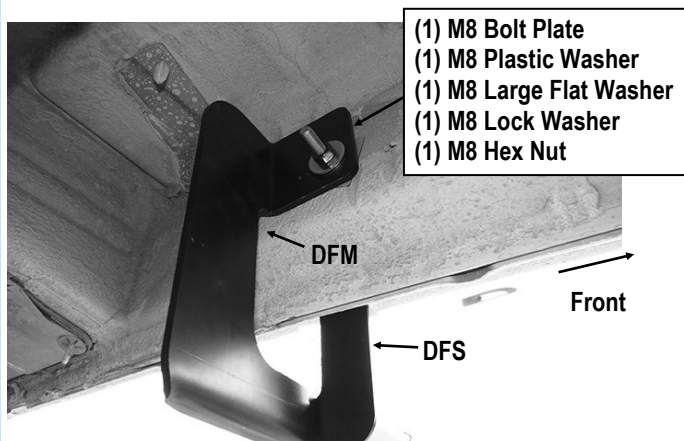

(Fig 3) Driver Front Mounting Bracket Installation

## STEP 5

Move to the driver side rear mounting location. Locate the factory hole in the bottom of the floor panel, (Fig 4). Repeat Steps 1-4 to attach the Driver Rear Mounting Bracket (DRM) and Support Bracket, (Fig 5).

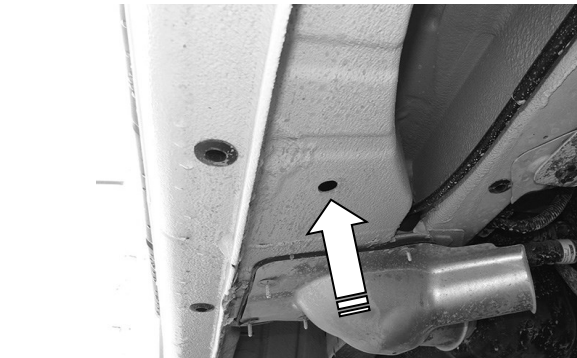

(Fig 4) Driver Side Rear Mounting Bracket Location

- (1) M8 Bolt Plate
- (1) M8 Plastic Washer
- (1) M8 Large Flat Washer
- (1) M8 Lock Washer
- (1) M8 Hex Nut

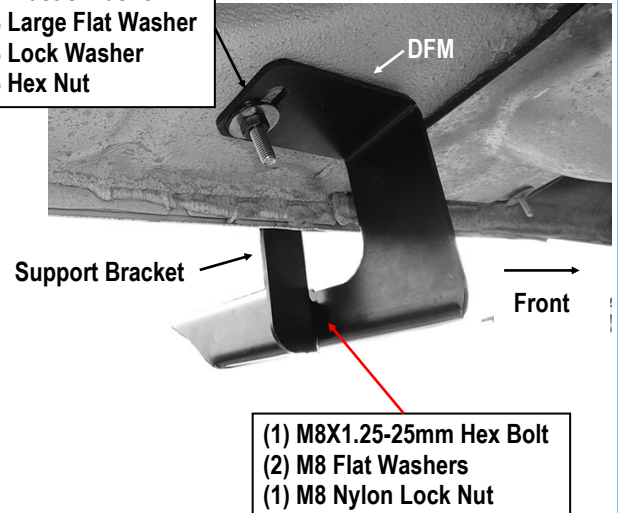

(Fig 5) Driver Rear Mounting Bracket Installation

## STEP 6

Select the Driver Side Running Board. Slip (2) M6x1-20mm Square Head Bolts into each bottom channel (Fig 6). Carefully position the Running Board onto the (2) Mounting Brackets.

**IMPORTANT:** Do not slide the Running Board on the Brackets or the bottom surface of the board will be damaged. Attach the Running Board to each Mounting Bracket with (2) M6x1-20mm Square Head Bolts, (2) M6 Large Flat Washers and (2) M6 Nylon Lock Nuts (Fig 7). Do not fully tighten hardware at this time.

- M6X1-20mm Square Head Bolts

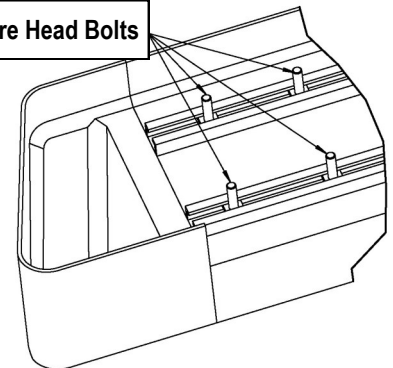

(Fig 6) Slip M6X1-20mm Square Head Bolts Into The Bottom Channels

# iBoard®

- (2) M6X1-20mm Square Head Bolts
- (2) M6 Large Flat Washers
- (2) M6 Nylon Lock Nuts

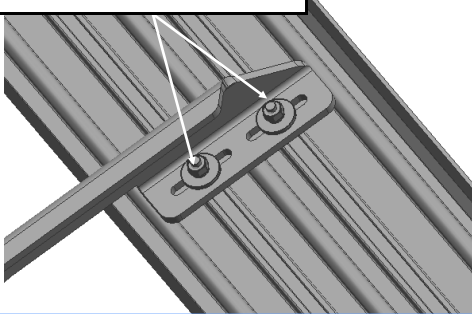

(Fig 7) Running Board Installed Onto Mounting Bracket (Example)

## STEP 7

Adjust the (2) Support Brackets as necessary to move the top of the Brackets up to touch the bend in the pinch weld.

Mark the location of the (2) slots in the Support Brackets onto the outside of the pinch weld, (Fig 8). Use a 5/16" drill bit to drill (2) holes through the pinch weld for the front and rear Support Brackets, (Fig 8).

**NOTE:** Drill the holes as far away from the bottom edge of the pinch weld as possible. **IMPORTANT:** Do not drill through the welds in the pinch weld if possible.

**IMPORTANT!** Any cutting or drilling tool may break or shatter. Government regulations require safety glasses & equipment at all times when cutting or drilling.

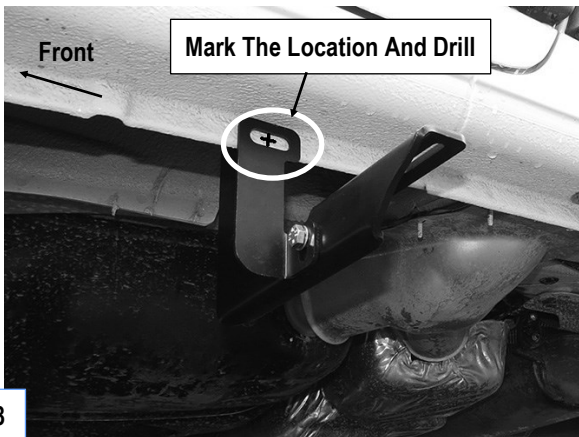
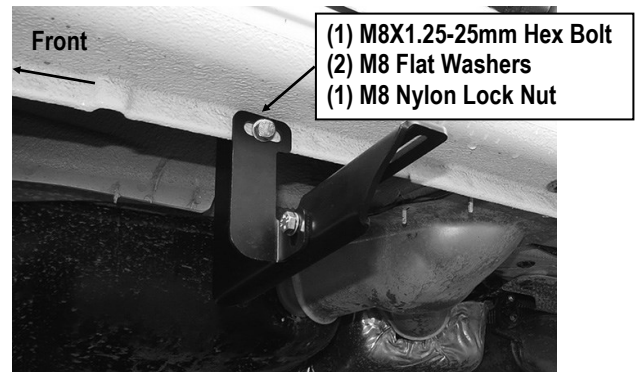

Fig 8

## STEP 8

Attach the top of the Support Brackets to the outside of the pinch weld with (1) M8X1.25-25mm Hex Bolt, (2) M8 Flat Washers and (1) M8 Nylon Lock Nut, (Fig 9). Reinstall the Running Board. Level, adjust and tighten all hardware.



(Fig 9) Attach Driver Side Support Bracket To Pinch Weld

## STEP 9

Move to the passenger side front of the vehicle, (Fig 10A & 10B). Repeat **Steps 1-4** to install and assemble the Passenger Front Mounting Bracket (PFM) and the Support Bracket, (Fig 11).

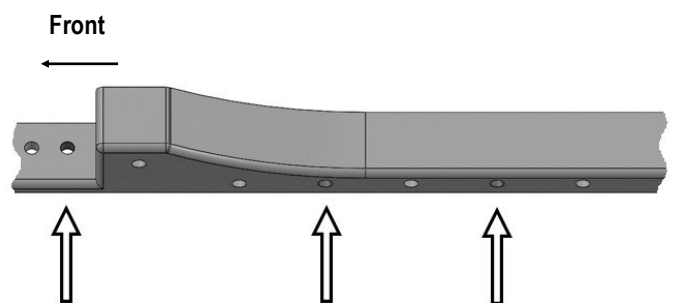

(Fig 10A) Passenger Side Mounting Bracket Locations

# iBoard®

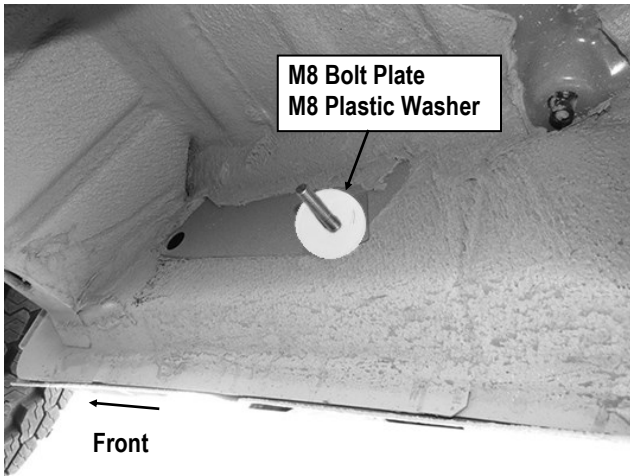

(Fig 10B) Passenger Side Front Mounting Bracket Location

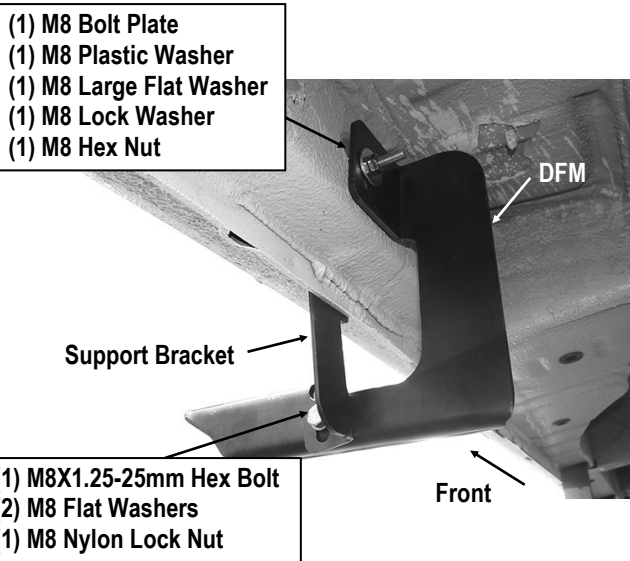

(Fig 11) Passenger Side Front Bracket Installation

## STEP 10

Continue to the center & rear mounting locations, (Fig12). Repeat **Steps 1-4** to install and assemble the Passenger Center & Rear Mounting Bracket and the Support Bracket.

**Note:** Passenger Side Center & Rear Mounting Bracket are universal.

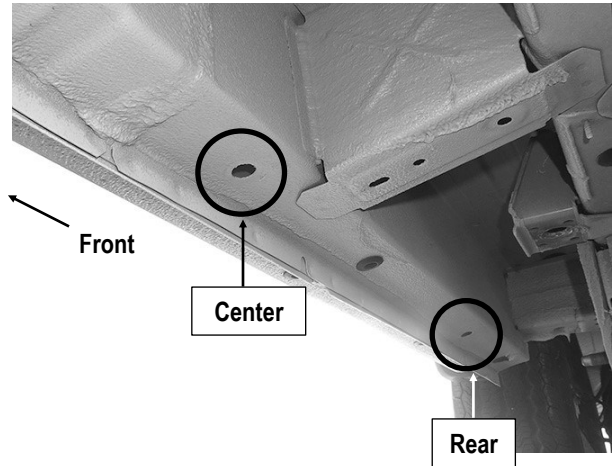

(Fig 12) Passenger Side Center & Rear Mounting Locations

## STEP 11

Select the Passenger Side Running Board. Slip (3) M6x1-20mm Square Head Bolts into each bottom channel (Fig 6). Repeat **Step 6** to attach the Running Board to (3) Mounting Brackets. Do not fully tighten hardware at this time.

## STEP 12

Repeat **Steps 7-8** to drill and attach the (3) Support Brackets to the pinch weld, (Figs 13-14).

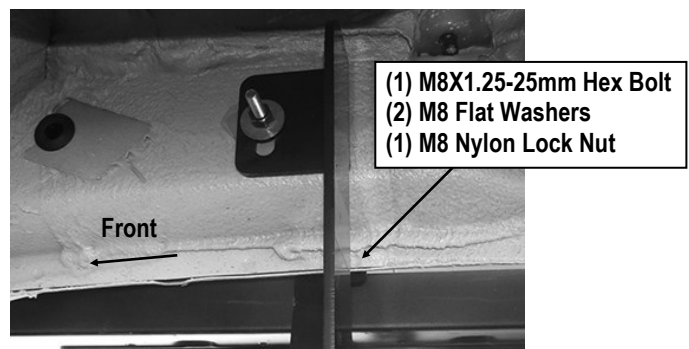

(Fig 13) Attach Passenger Front Support Bracket To Pinch Weld

# iBoard®

## STEP 13

Level and adjust the Running Board and fully tighten all hardware. Installation completed.

### Attention

Do periodic inspections to the installation to make sure that all hardware is secure and tight.

In order to protect your bars/boards, please use only mild soap/non-abrasive products for cleaning.

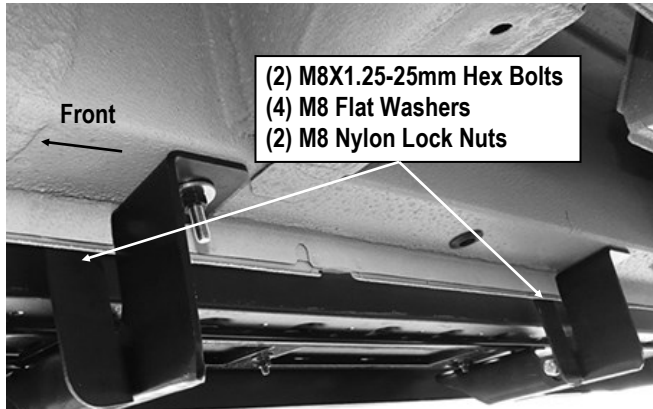

(Fig 14) Attach Passenger Center & Rear Support Bracket To Pinch Weld