

iBoard®

iBoard® by APS

PART#: IB-R401

READ INSTRUCTIONS CAREFULLY BEFORE STARTING INSTALLATION. REMOVE CONTENTS FROM BOX AND VERIFY ALL PARTS ARE PRESENT. ASSISTANCE IS RECOMMENDED.

*ROCKER PANEL MOUNT
*DRILLING IS REQUIRED

Fastener Size	Tightening Torque (ft-lbs)	Required
6mm	6-7	√
8mm	16-18	√
10mm	31-32	X
12mm	56-58	X
14mm	92-94	X

PART LIST

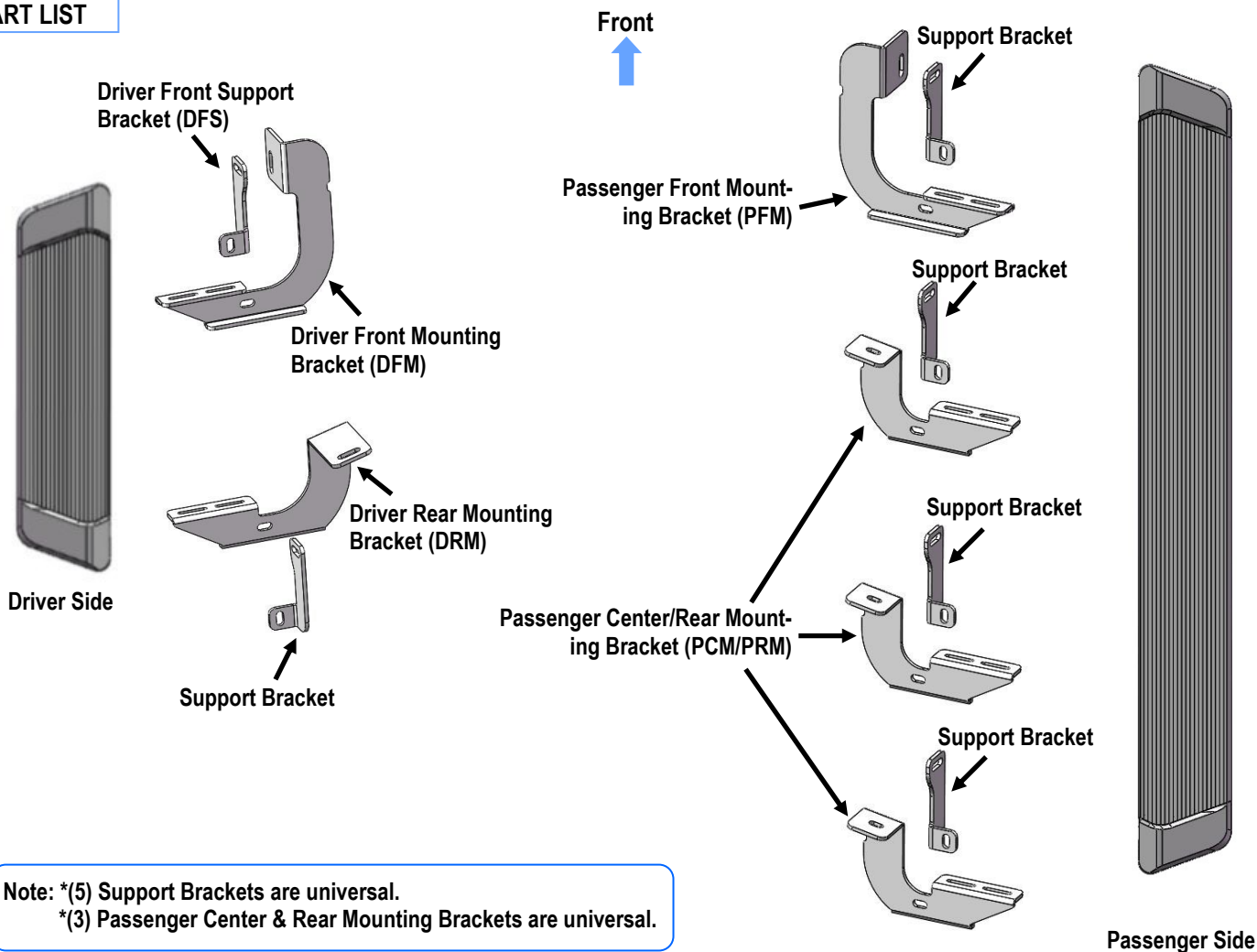

Customer Support: info@iboardauto.com

iBoard®

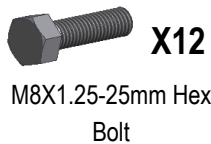
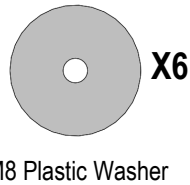

STEP 1

Starting installation from the driver side front of the vehicle. Locate the factory hole on the inner side of the body panel, (**Fig 1A & 1B**).

IMPORTANT: Holes may be covered with rubber plug, sealing tape and/or heavy undercoating. Remove undercoating from all mounting locations so that Brackets can be installed flatly against body panel and pinch weld.

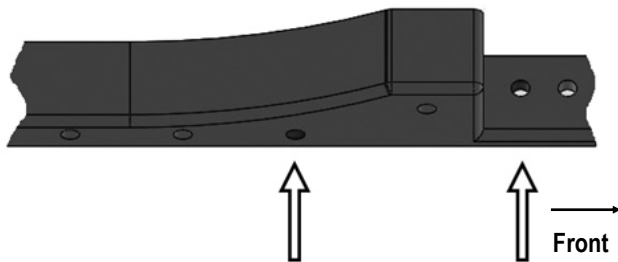

(Fig 1A) Driver Side Front & Rear Mounting Locations



(Fig 1B) Driver Side Front Mounting Location

STEP 2

Select (1) M8 Bolt Plate and (1) M8 Plastic Washer. Thread the M8 Plastic Washer onto the M8 Bolt Plate. Insert the M8 Bolt Plate into the hole and tighten the M8 Plastic Washer against the body panel, (**Fig 1B**).

NOTE: The M8 Plastic Washer is designed to hold the M8 Bolt Plate in place within Bracket installation.

STEP 3

Select the Driver Front Mounting Bracket (**DFM**) and the Driver Front Support Bracket (**DFS**). Attach the Support Bracket to the front of the Mounting Bracket with (1) M8X1.25-25mm Hex Bolt, (2) M8 Flat Washers and (1) M8 Nylon Lock Nut, (**Fig 2**). Do not fully tighten hardware at this time.

Note: Driver Front Support Bracket (**DFS**) are different with the other (5) Support Brackets.

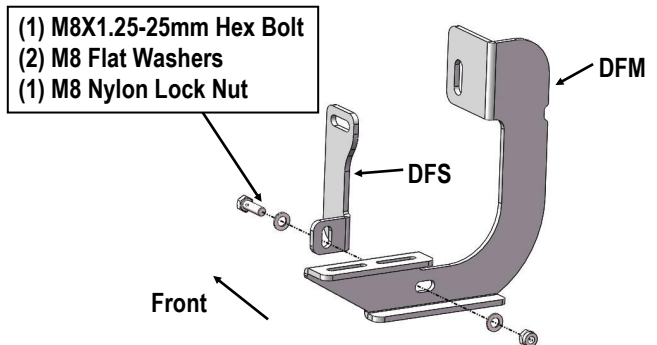

(Fig 2) Driver Front Mounting Bracket and the Driver Front Support Bracket Assembly

iBoard®

STEP 4

Attach the Driver Front Mounting Bracket (DFM) to the installed M8 Bolt Plate with (1) M8 Large Flat Washer, (1) M8 Lock Washer and (1) M8 Hex Nut, (Fig 3). Do not fully tighten hardware at this time.

Line up the top of the Support Bracket with the outside of the pinch weld.

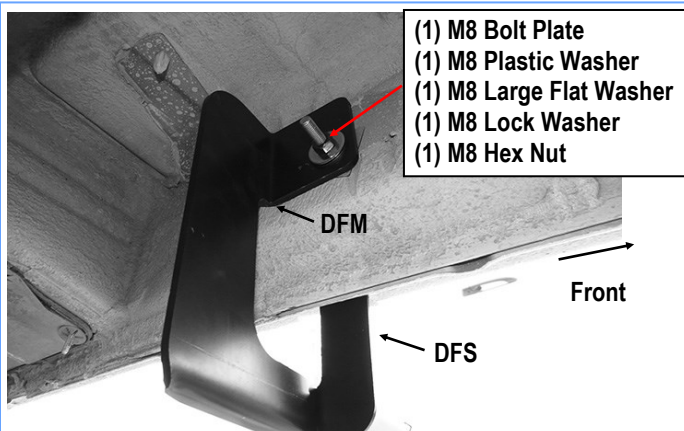

(Fig 3) Driver Front Mounting Bracket Installation

STEP 5

Move to the driver side rear mounting location. Locate the factory hole in the bottom of the floor panel, (Fig 4). Repeat Steps 1-4 to assemble and install the Driver Rear Mounting Bracket (DRM) and Support Bracket, (Fig 5).

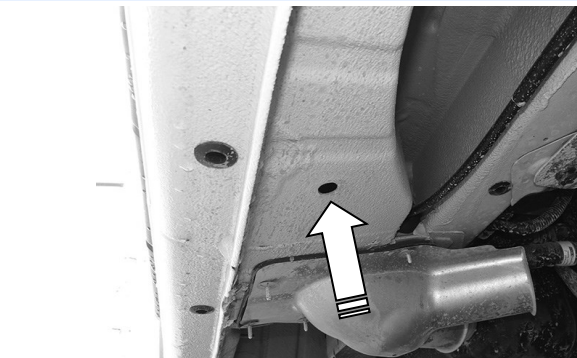

(Fig 4) Driver Side Rear Mounting Location

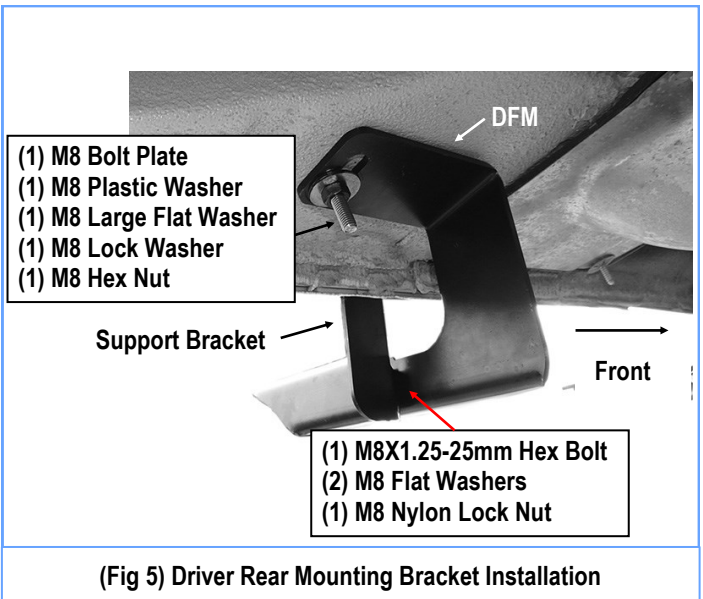

(Fig 5) Driver Rear Mounting Bracket Installation

STEP 6

Select the Driver Side Running Board. Slip (2) M6x1-20mm Square Head Bolts into each bottom channel (Fig 6). Carefully position the Running Board onto the (2) Mounting Brackets.

IMPORTANT: Do not slide the Running Board on the Brackets or the bottom surface of the board will be damaged. Attach the Running Board to each Mounting Bracket with (2) M6x1-20mm Square Head Bolts, (2) M6 Large Flat Washers and (2) M6 Nylon Lock Nuts (Fig 7). Do not fully tighten hardware at this time.

M6X1-20mm Square Head Bolts

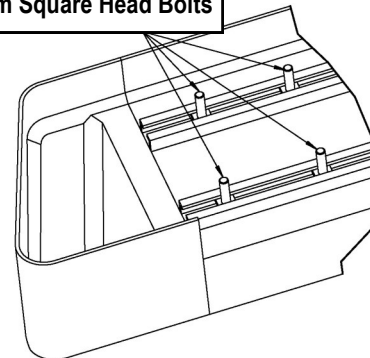

(Fig 6) Slip M6X1-20mm Square Head Bolts Into The Bottom Channels

iBoard®

- (2) M6X1-20mm Square Head Bolts
- (2) M6 Large Flat Washers
- (2) M6 Nylon Lock Nuts

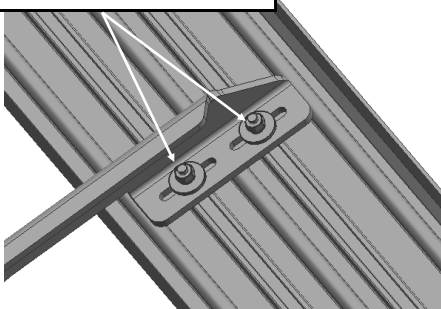

(Fig 7) Running Board Installed Onto Mounting Bracket (Example)

STEP 7

Adjust the (2) Support Brackets, attach the Brackets to the outside of the pinch weld. Mark the location of the (2) slots in the Support Brackets onto the pinch weld, (Fig 8). Drill (2) 5/16" through holes in the pinch weld for the front and rear Support Brackets, (Fig 8).

NOTE: Drill the holes as far away from the bottom edge of the pinch weld as possible. Do not drill on the welds on the pinch weld if possible.

IMPORTANT! Any cutting or drilling tool may break or shatter. Government regulations require safety glasses & equipment at all times when cutting or drilling.

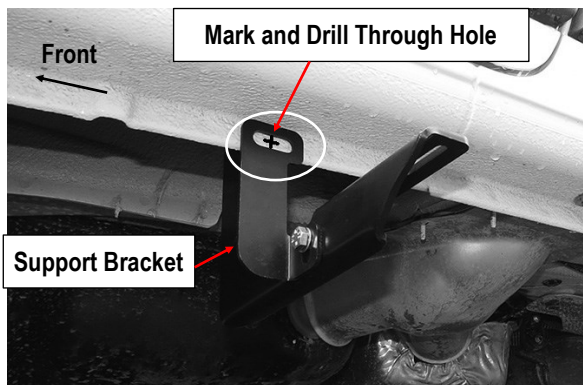

(Fig 8) Mark and Drill Through Holes on Pinch Weld

STEP 8

Secure each Support Bracket to the outside of the pinch weld with (1) M8X1.25-25mm Hex Bolt, (2) M8 Flat Washers and (1) M8 Nylon Lock Nut, (Fig 9). Reinstall the Running Board. Level, adjust and tighten all hardware.

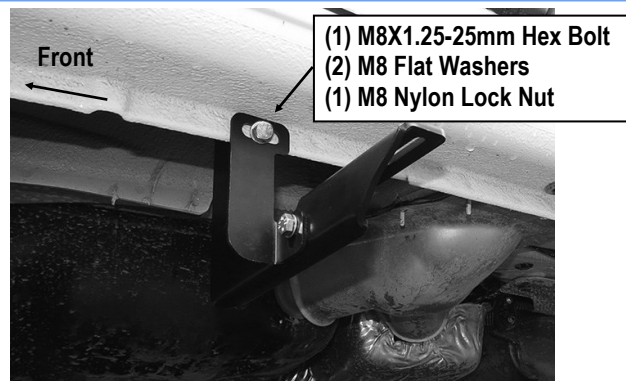

(Fig 9) Driver Side Support Bracket Installed on Pinch Weld

STEP 9

Move to the passenger side front of the vehicle, (Fig 10A & 10B). Repeat Steps 1-4 to assemble and install the Passenger Front Mounting Bracket (PFM) and the Support Bracket, (Fig 11).

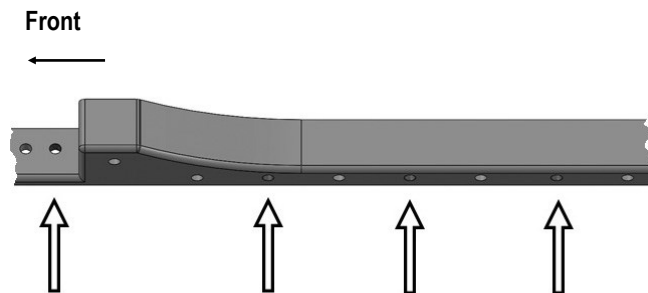

(Fig 10A) Passenger Side Mounting Bracket Locations

iBoard®

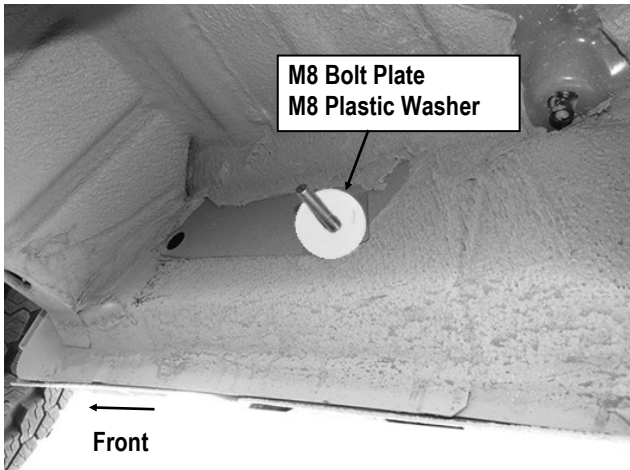

(Fig 10B) Passenger Side Front Mounting Location

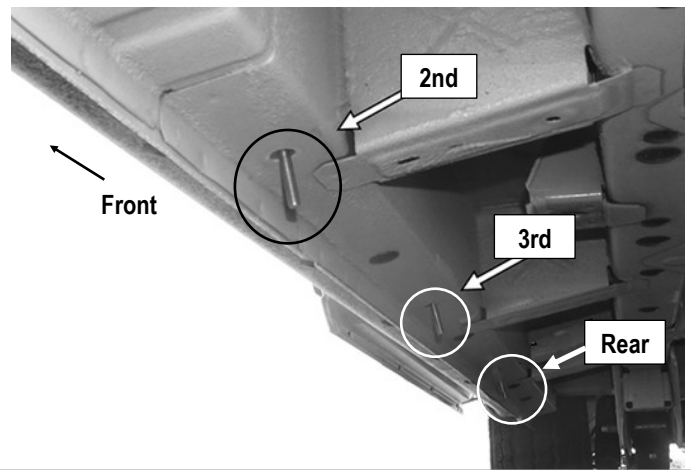

(Fig 12) Passenger Side Center & Rear Mounting Locations

- (1) M8 Bolt Plate
- (1) M8 Plastic Washer
- (1) M8 Large Flat Washer
- (1) M8 Lock Washer
- (1) M8 Hex Nut

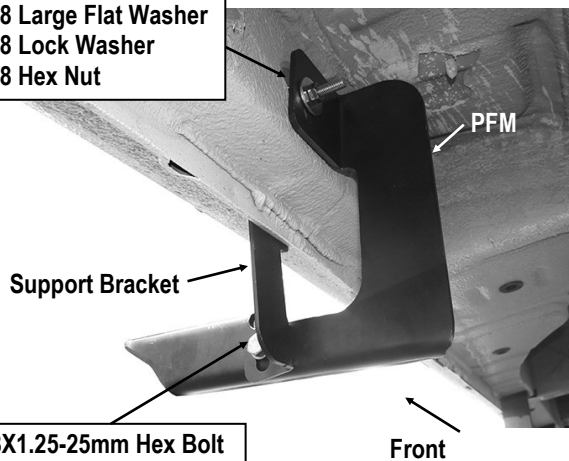

- (1) M8X1.25-25mm Hex Bolt
- (2) M8 Flat Washers
- (1) M8 Nylon Lock Nut

(Fig 11) Passenger Side Front Brackets Installation

STEP 10

Continue to the 2nd & 3rd & rear mounting locations, (Fig12). Repeat **Steps 1-4** to install and assemble the Mounting Brackets and the Support Brackets.

Note: Passenger Side 2nd & 3rd & Rear Mounting Brackets are universal.

STEP 11

Select the Passenger Side Running Board. Slip (4) M6x1-20mm Square Head Bolts into each bottom channel (Fig 6). Repeat **Step 6** to attach the Running Board to (4) Mounting Brackets. Do not fully tighten hardware at this time.

STEP 12

Adjust the locations of (4) support brackets, repeat **Step 7** to mark and drill holes on pinch weld. Repeat **step 8** to secure the (4) Support Brackets to the outside of pinch weld, (Figs 13-14).

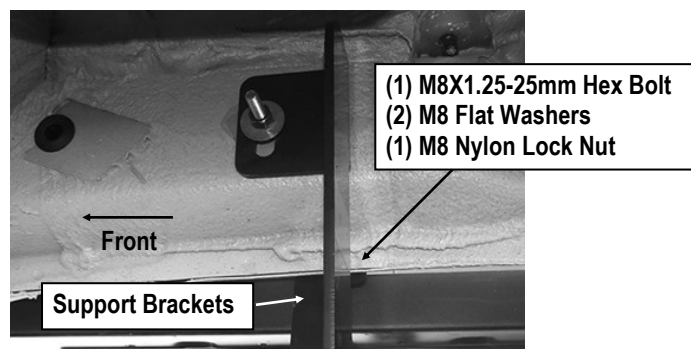

(Fig 13) Attach Passenger Front Support Bracket To Pinch Weld

iBoard®

STEP 13

Level and adjust the Running Board and fully tighten all hardware. The installation is completed.

Attention

Do periodic inspections to the installation to make sure that all hardware is secure and tight.

In order to protect your bars/boards, please use only mild soap/non-abrasive products for cleaning.

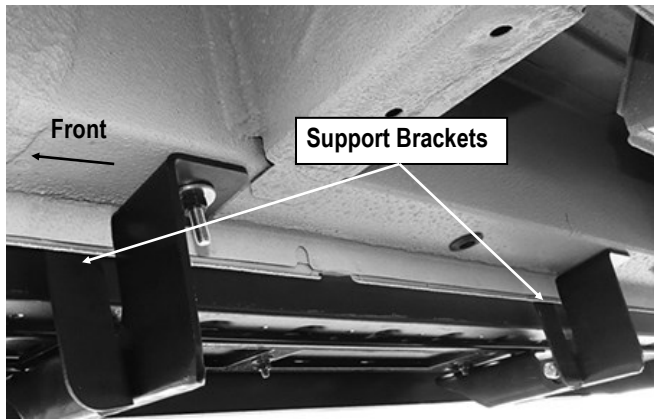

(Fig 14) Passenger 2nd & 3rd Support Brackets Locations On Pinch Weld