

# iBoard®

## iBoard® by APS

PART#: IB-R361

READ INSTRUCTIONS CAREFULLY BEFORE STARTING INSTALLATION. REMOVE CONTENTS FROM BOX AND VERIFY ALL PARTS ARE PRESENT. ASSISTANCE IS RECOMMENDED.

\*ROCKER PANEL MOUNT  
\*NO DRILLING REQUIRED

Fastener Size	Tightening Torque (ft-lbs)	Required
6mm	6-7	√
8mm	16-18	√
10mm	31-32	√
12mm	56-58	X
14mm	92-94	X

Item	QTY	Description	Item	QTY	Description
1#	1	Driver Front Mounting Bracket	12#	7	M10 Plastic Washers
2#	1	Driver Center Mounting Bracket	13#	1	M10X1.5-30mm Hex Bolt
3#	1	Driver Rear Mounting Bracket	14#	9	M10 Flat Washers
4#	2	Driver Front / Passenger Rear Bar Brackets	15#	8	M10 Lock Washers
5#	1	Passenger Front Mounting Bracket	16#	8	M10 Hex Nuts
6#	1	Passenger Center Mounting Bracket	17#	8	M8X1.25-30mm Hex Bolts
7#	1	Passenger Rear Mounting Bracket	18#	16	M8 Flat Washers
8#	2	Passenger Front / Driver Rear Bar Brackets	19#	8	M8 Nylon Lock Nuts
9#	1	Driver Center Support Bracket	20#	12	M6X1-20mm Square Head Bolts
10#	5	M10 L Bolt Plates	21#	12	M6 Large Flat Washers
11#	2	M10 T Bolt Plates	22#	12	M6 Nylon Lock Nuts

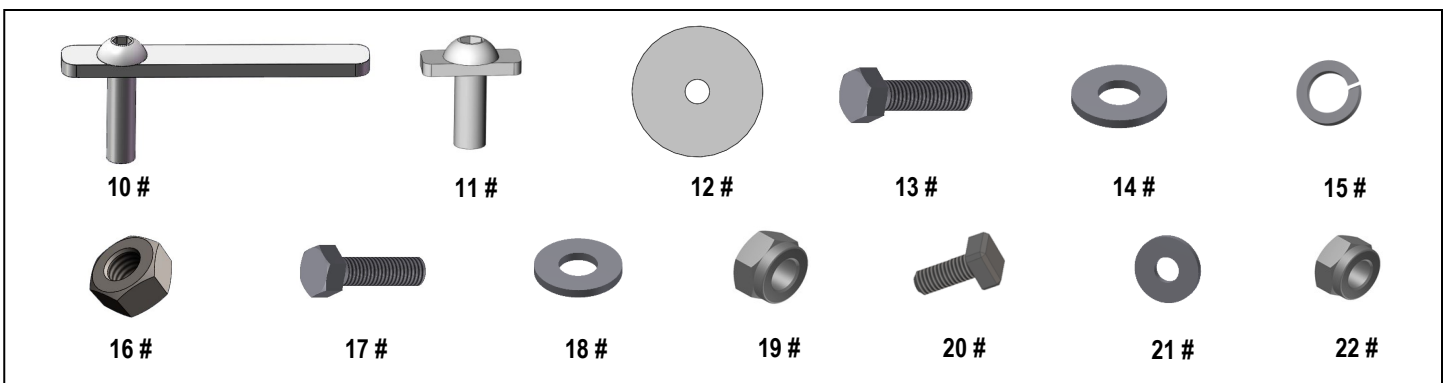

Customer Support: [info@iboardauto.com](mailto:info@iboardauto.com)

# iBoard®

Driver

Front

Passenger

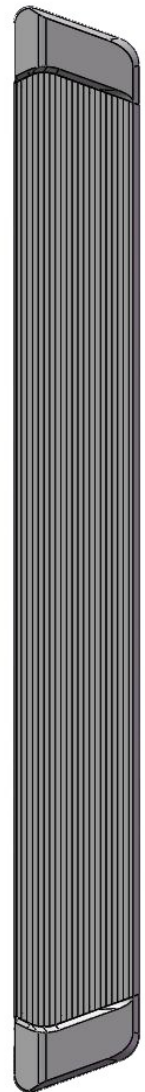
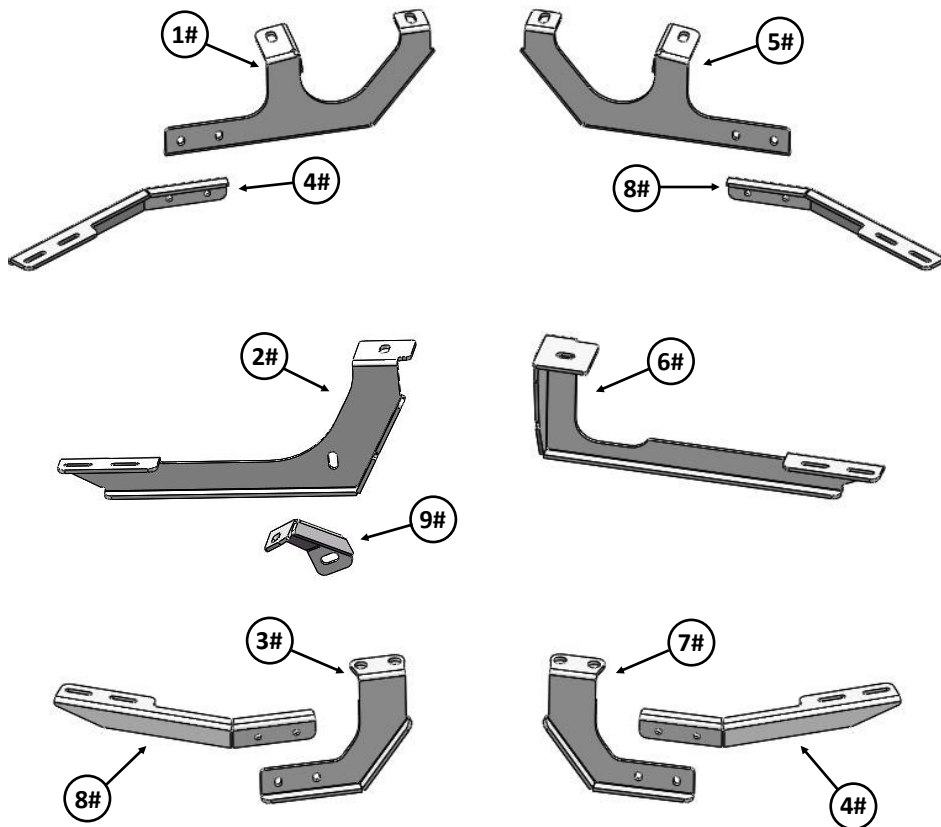
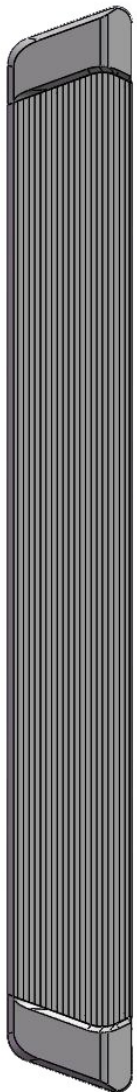

# iBoard®

## STEP 1

Start installation from the passenger side front of the vehicle. Locate the factory holes at the bottom of the floor panel, (**Fig 1**). **NOTE:** The mounting locations may be covered by sealant or undercoating. Use a small screwdriver to poke through the sealant to uncover the hole.

**IMPORTANT:** Brackets must sit flat against sheet metal. Scrape any excess sealant from body panel before installing any Bracket.

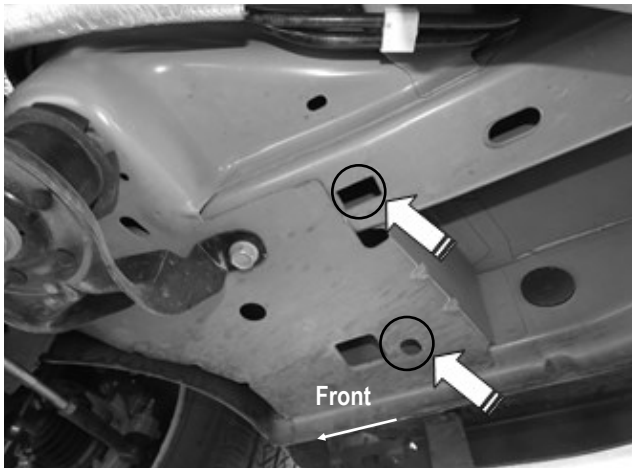

(Fig 1) Passenger Side Front Mounting Location

## STEP 2

Select (2) M10 L Bolt Plates and (2) M10 Plastic Washers. Partially thread the Plastic Washers onto the M10 L Bolt Plates. Insert the M10 L Bolt Plates with Plastic Washers into the front mounting holes, (**Fig 2**). Thread the Plastic Washer down until it is tight against the floor panel. The Plastic Washer is designed to hold the M10 L Bolt Plate in place during Bracket installation.

**NOTE:** Hold the Passenger Front Mounting Bracket up to the passenger side front mounting location to help to determine the correct mounting holes.

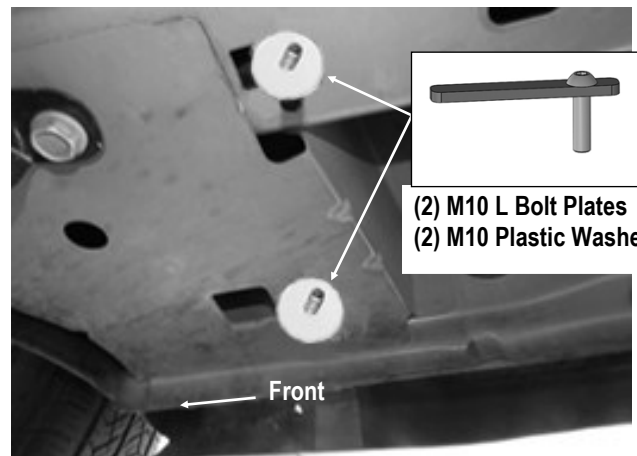

(Fig 2) M10 L Bolt Plates Installed In The Front Mounting Holes (Secure With M10 Plastic Washers)

## STEP 3

Next, assemble Passenger Front Mounting Bracket and Passenger Front Bar Bracket using (2) M8X1.25-30mm Hex Bolts, (4) M8 Flat Washers and (2) M8 Nylon Lock Nuts, (**Fig 3**). Do not fully tighten hardware at this time.

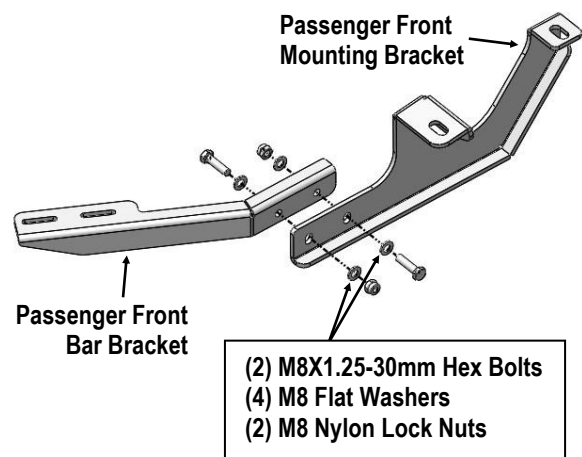

(Fig 3) Passenger Side Front Brackets Assembly

# iBoard®

## STEP 4

Attach the assembled Passenger Front Mounting Bracket to the installed (2) M10 L Bolt Plates with (2) M10 Flat Washers, (2) M10 Lock Washers and (2) M10 Hex Nuts, (Fig 4). Do not fully tighten hardware at this time.

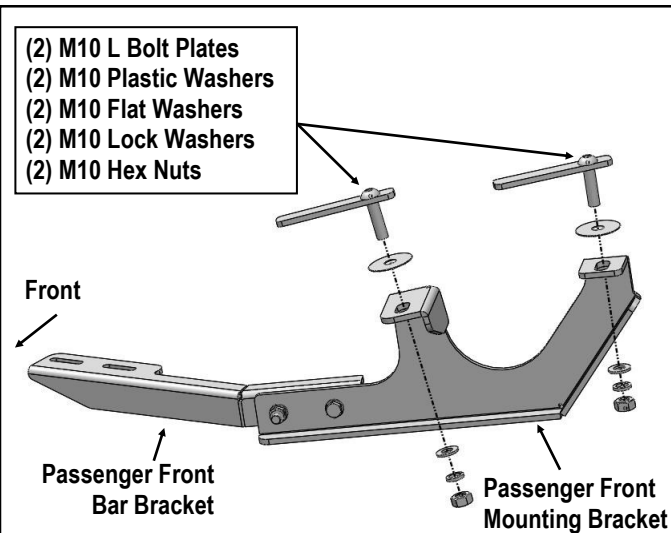

(Fig 4) Passenger Front Mounting Bracket Installed

## STEP 5

Move to the passenger side center mounting location, (Fig 5). Locate the large slot above the passenger side exhaust pipe, (Fig 5).

Next, select (1) M10 T Bolt Plate and (1) M10 Plastic Washer. Partially thread the Plastic Washer onto the M10 T Bolt Plate. Insert the M10 T Bolt Plate with Plastic Washer into the front mounting hole, (Fig 6). Thread the Plastic Washer down until it is tight against the floor panel. The Plastic Washer is designed to hold the M10 T Bolt Plate in place during Bracket installation.

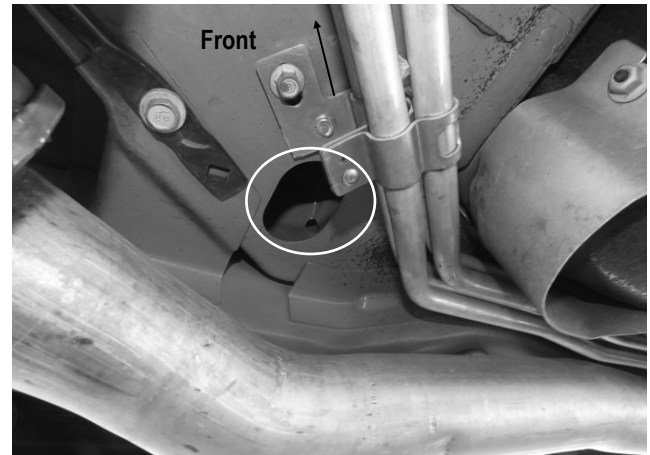

(Fig 5) Passenger Side Center Mounting Location

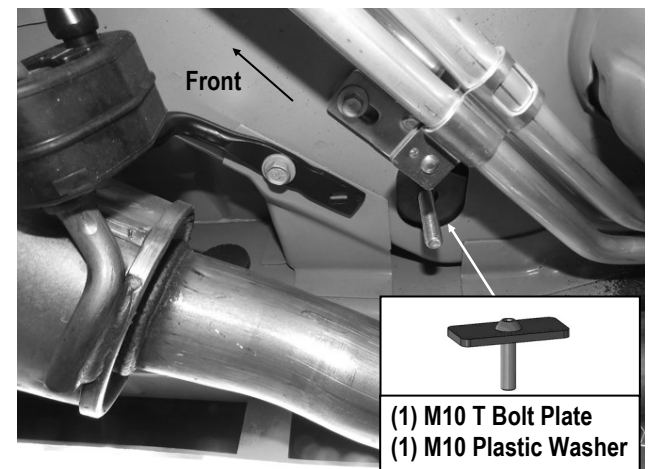

(Fig 6) M10 T Bolt Plate Installed on the Passenger Side Center Mounting Location

## STEP 6

Attach Passenger Center Mounting Bracket to the installed M10 T Bolt Plate with (1) M10 Flat Washer, (1) M10 Lock Washer and (1) M10 Hex Nut, (Fig 7). Do not fully tighten hardware at this time.

# iBoard®

## STEP 8

Assemble Passenger Rear Mounting Bracket and Passenger Rear Bar Bracket, (Fig 9). Do not fully tighten hardware at this time.

Then, reuse the (2) factory hex bolts to attach the Passenger Rear Mounting Bracket to the rear mounting location, (Fig 10). Do not fully tighten hardware at this time.

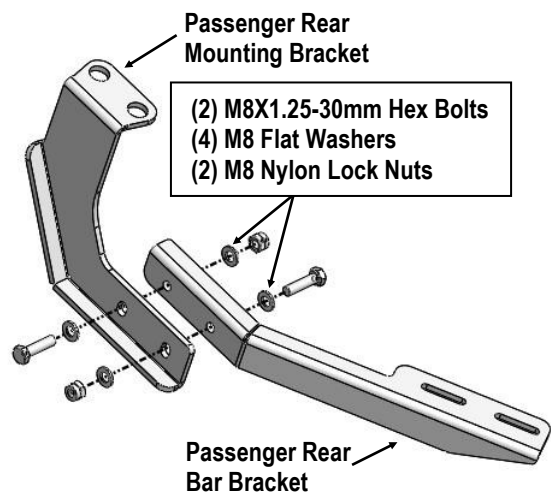

(Fig 9) Passenger Side Rear Brackets Assembly

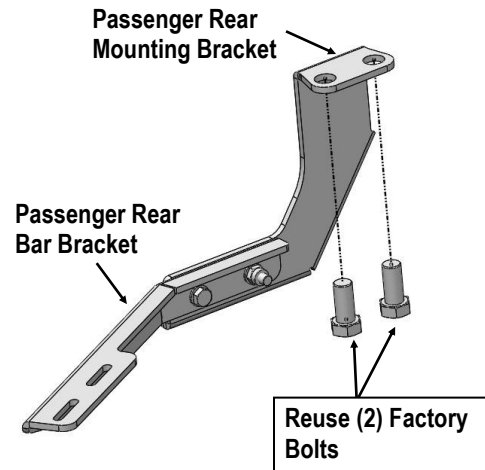

(Fig 10) Passenger Rear Mounting Bracket Installed

- (1) M10 T Bolt Plate
- (1) M10 Plastic Washer
- (1) M10 Flat Washer
- (1) M10 Lock Washer
- (1) M10 Hex Nut

Front

(Fig 7) Passenger Center Mounting Bracket Installed

## STEP 7

Move to the passenger side rear mounting location, (Fig 8). Remove the (2) factory hex bolts (Fig 8).

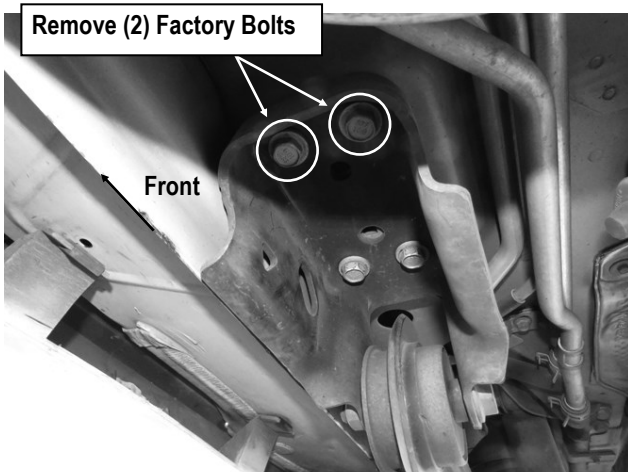

(Fig 8) Passenger Side Rear Mounting Location

# iBoard®

## STEP 9

Select a Running Board. Slip (3) M6x1-20mm Square Head Bolts into each bottom channel (**Fig 11**). Carefully position the Running Board onto the (3) Mounting Brackets.

**IMPORTANT:** Do not slide the Running Board on the Brackets or the bottom surface of the board will be damaged. Attach the Running Board to each Mounting Bracket with (2) M6x1-20mm Square Head Bolts, (2) M6 Large Flat Washers and (2) M6 Nylon Lock Nuts (**Fig 12**). Do not fully tighten at this time.

M6X1-20mm Square Head Bolts

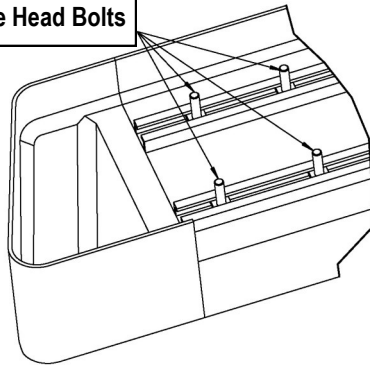

(Fig 11) Slip M6X1-20mm Square Head Bolts Into The Bottom Channels

(2) M6X1-20mm Square Head Bolts  
(2) M6 Large Flat Washers  
(2) M6 Nylon Lock Nuts

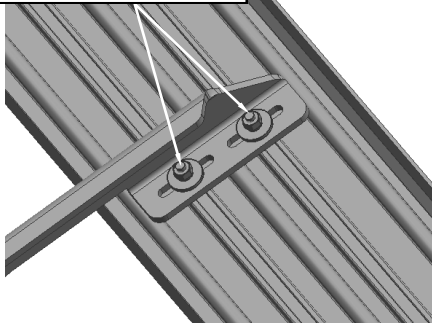

(Fig 12) Running Board Installed Onto Mounting Bracket

## STEP 10

Level and adjust the Running Board and fully tighten all hardware.

**Important:** Please follow the recommended Tightening Torques shown in the table on page 1. Don't over tighten, or the nuts/bolts will be damaged.

## STEP 11

Move to Driver side of the vehicle. Start installation from the driver side front of the vehicle. Repeat **Steps 1-4** for Driver Front Bar Bracket and Driver Front Mounting Bracket installation.

## STEP 12

Move to the Driver Center Mounting Location, (**Fig 13**). Locate the large hole and remove the plastic plug coving the hole on the frame channel, (**Fig 13**). And then, Insert the remaining (1) M10 L Bolt Plate with (1) M10 Plastic Washer and (1) M10 T Bolt Plate with (1) Plastic Washer into the holes, (**Fig 13**).

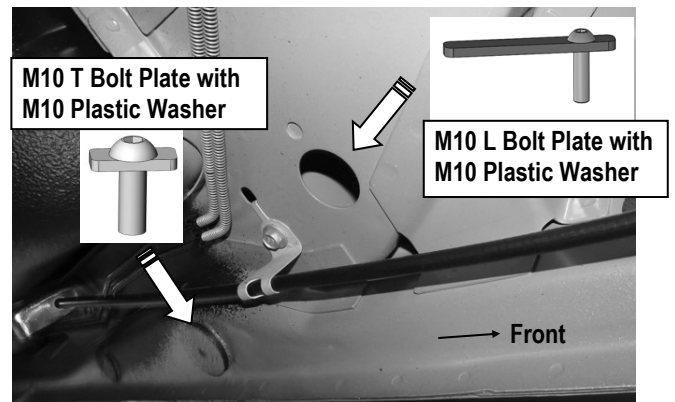

(Fig 13) Driver Side Center Mounting Location

# iBoard®

## STEP 13

Assemble Driver Center Mounting Bracket and Driver Center Support Bracket with (1) M10x1.5-30mm Hex Bolt, (2) M10 Flat Washers, (1) M10 Lock Washer and (1) M10 Hex Nut, (Fig 14). Do not fully tighten hardware at this time.

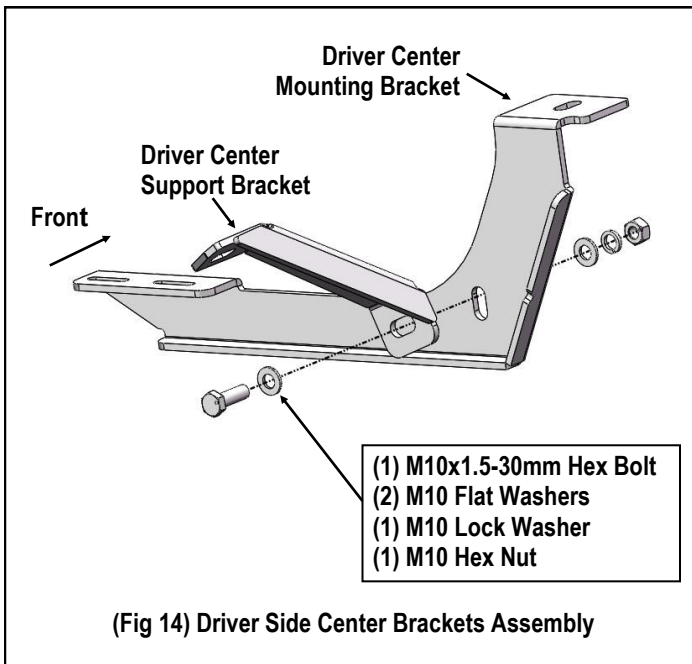

## STEP 14

Next, repeat **Step 5** to install the assembled Driver Center Mounting Bracket to the installed M10 L Bolt Plate, (Fig 15). Attach the Driver Center Support Bracket to the installed M10 T Bolt Plate with (1) M10 Flat Washer, (1) M10 Lock Washer and (1) M10 Hex Nut, (Fig 15). Do not fully tighten hardware at this time.

## STEP 15

Repeat **Steps 7—8** for Driver Rear Mounting Bracket installation.

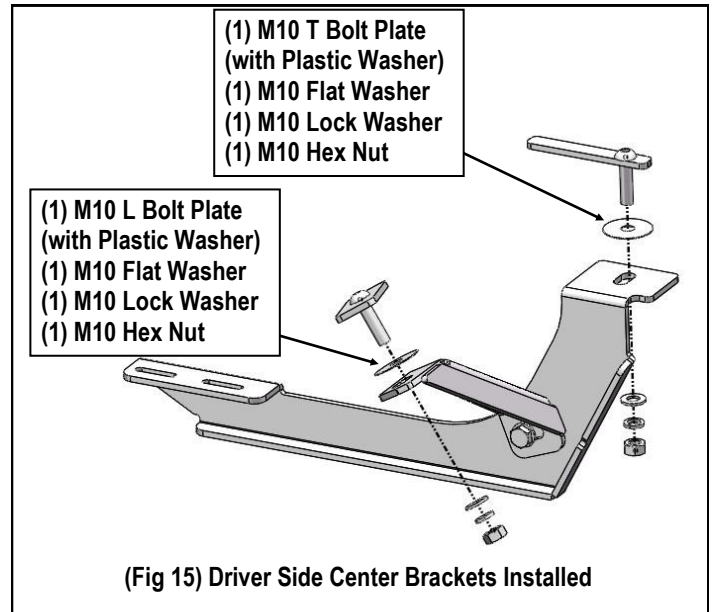

## STEP 16

Repeat **Steps 9-10** for the other side Running Board installation. The installation is completed .

### Attention

Do periodic inspections to the installation to make sure that all hardware is secure and tight.

In order to protect your bars/boards, please use only mild soap/non-abrasive products for cleaning.