

iBoard®

iBoard® by APS

PART#: IB-R178

READ INSTRUCTIONS CAREFULLY BEFORE STARTING INSTALLATION. REMOVE CONTENTS FROM BOX AND VERIFY ALL PARTS ARE PRESENT. ASSISTANCE IS RECOMMENDED.

*ROCKER PANEL MOUNT
*DRILLING MAY BE REQUIRED

| Fastener Size | Tightening Torque (ft-lbs) | Required |
|---------------|----------------------------|----------|
| 6mm | 6-7 | √ |
| 8mm | 16-18 | √ |
| 10mm | 31-32 | √ |
| 12mm | 56-58 | X |
| 14mm | 92-94 | X |

| Item | QTY | Description | Item | QTY | Description |
|------|-----|----------------------------------|------|-----|-----------------------------|
| 1# | 1 | Passenger Front Mounting Bracket | 12# | 10 | M10 Lock Washers |
| 2# | 1 | Passenger Rear Mounting Bracket | 13# | 3 | M10 Hex Nuts |
| 3# | 1 | Driver Rear Mounting Bracket | 14# | 3 | M10 Rivet Nuts |
| 4# | 1 | Driver Front Mounting Bracket | 15# | 8 | M8X1.25-30mm Hex Bolts |
| 5# | 1 | Driver Front Support Bracket | 16# | 9 | M8 Large Flat Washers |
| 6# | 4 | M10 Bolt/Nut Plates | 17# | 7 | M8 Lock Washers |
| 7# | 4 | M10 Plastic Washers | 18# | 1 | M8 Nylon Lock Nut |
| 8# | 3 | M10X1.5-30mm Hex Bolts | 19# | 2 | M6X1-25mm Hex Bolts |
| 9# | 4 | M10X1.5-40mm Hex Bolts | 20# | 8 | M6X1-20mm Square Head Bolts |
| 10# | 7 | M10 Flat Washers | 21# | 12 | M6 Large Flat Washers |
| 11# | 3 | M10 Large Flat Washers | 22# | 10 | M6 Nylon Lock Nuts |

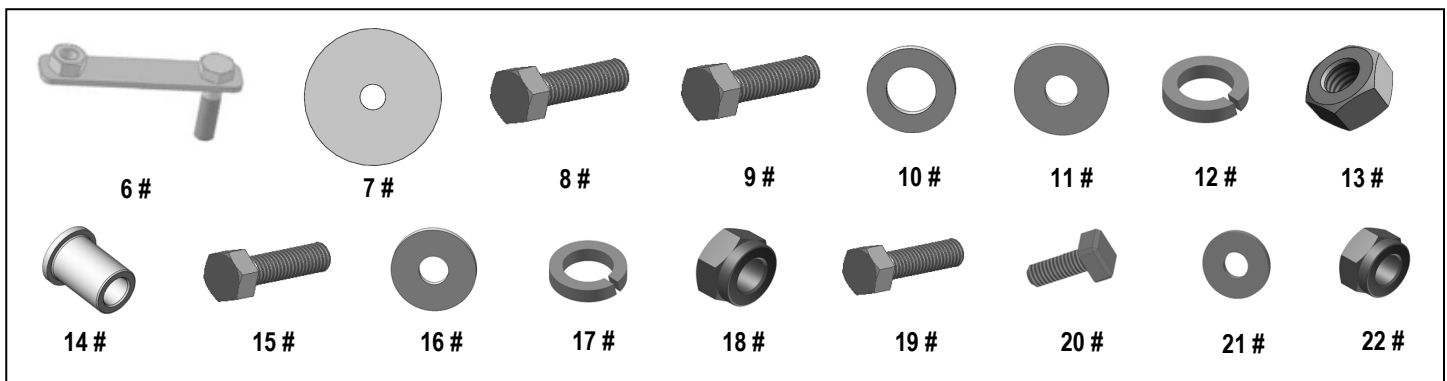

Customer Support: info@iboardauto.com

iBoard®

Driver

Front

Passenger

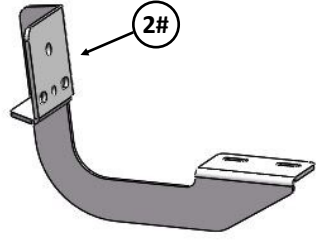
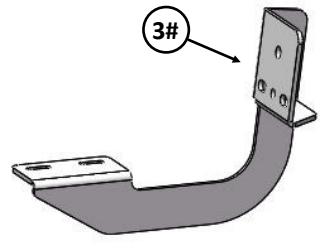
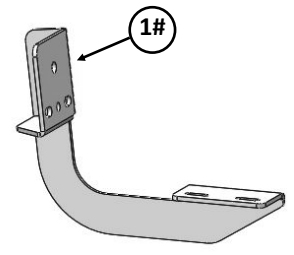
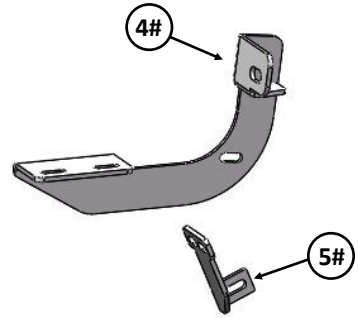
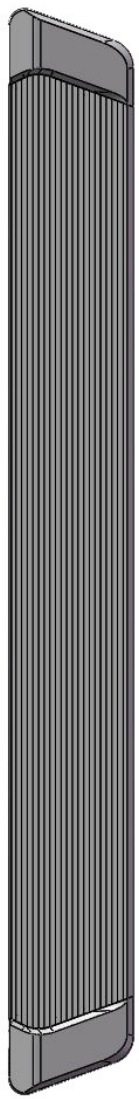
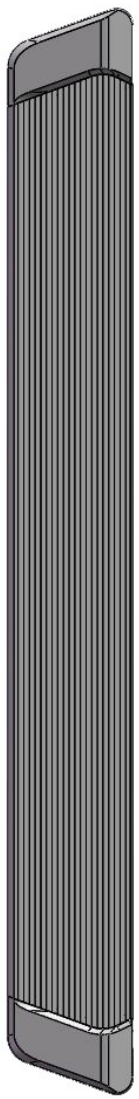

iBoard®

STEP 1

Starting at the driver side front of the vehicle, remove the sealing tape covering the factory holes in the side of the inner panel, (Fig 1).

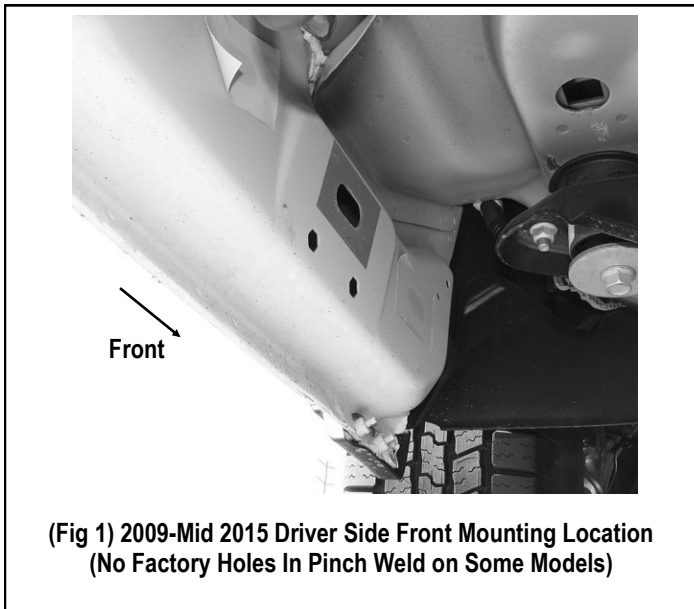

(Fig 1) 2009-Mid 2015 Driver Side Front Mounting Location (No Factory Holes In Pinch Weld on Some Models)

STEP 2

Determine the correct procedure to attach the Driver Front Mounting Bracket for your model/year:

Models without factory threaded inserts in body panel:

- Select (1) M10 Bolt/Nut Plate, insert the M10 Bolt/Nut Plate into the factory oval hole, (Fig 2). Thread (1) M10 Plastic Washer onto the welded bolt until it is flush against the sheet metal, (Fig 2). **NOTE:** The Plastic Washer is designed to keep the Bolt/Nut Plate out of falling into the body panel and to aid in Bracket installation.
- Select (1) Driver Front Mounting Bracket. Attach the Mounting Bracket to the inner panel and rotate the M10 Nut / Bolt Plate until the welded nut end lines up with the hole on the Mounting Bracket. Secure with (1) M10x1.5-40mm Hex Bolt, (1) M10 Lock Washer and (1) M10 Flat Washer, (Fig 7). Do not fully tighten at this time.

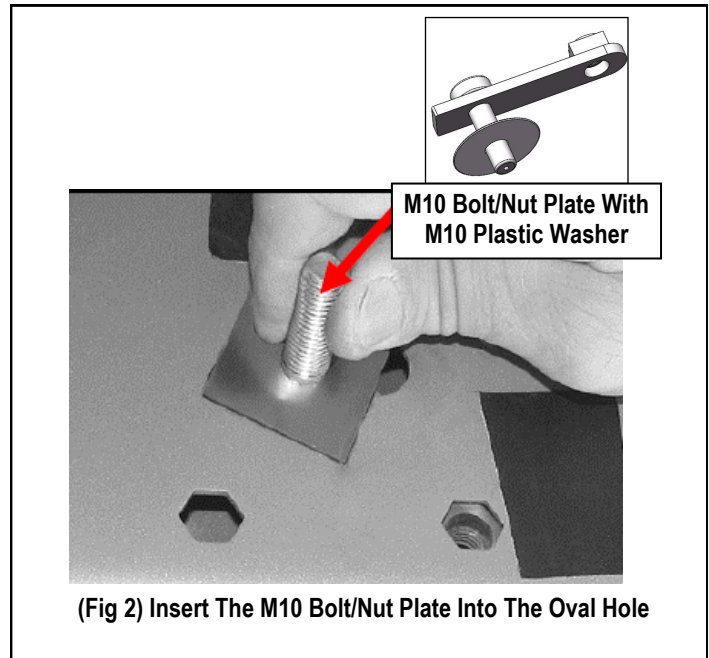

(Fig 2) Insert The M10 Bolt/Nut Plate Into The Oval Hole

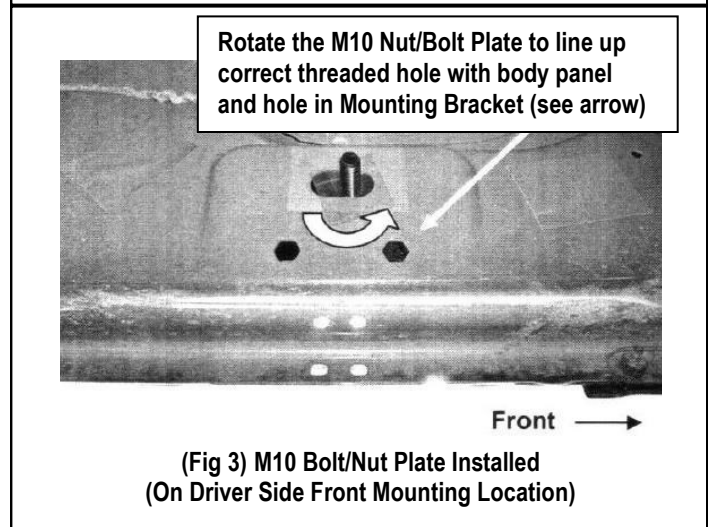

(Fig 3) M10 Bolt/Nut Plate Installed (On Driver Side Front Mounting Location)

STEP 3

Models with factory threaded inserts (Fig 4) :

Attach Driver Front Mounting Bracket to the threaded inserts with (1) M8x1.25-30mm Hex Bolt, (1) M8 Lock Washer and (1) M8 Large Flat Washer, (Fig 7). Do not fully tighten at this time.

iBoard®

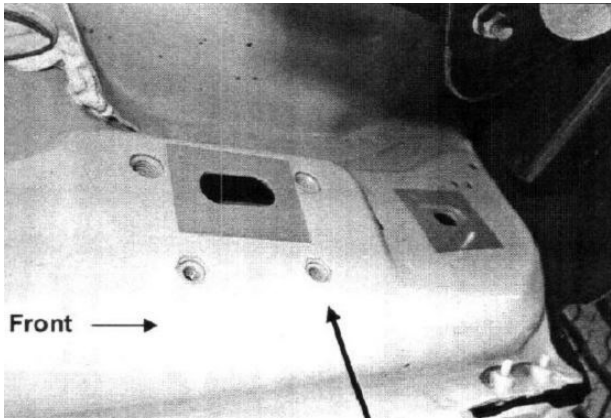

(Fig 4) Driver Side Front Mounting Location mid 15-on (Models With Factory Installed Threaded Inserts)

STEP 4

Attach the Driver Front Support Bracket to the Driver Front Mounting Bracket with (1) M8X1.25-30mm Hex Bolt, (2) M8 Large Flat Washers and (1) M8 Nylon Lock Nut, (Fig 5).

Rotate the support bracket to the back side of the pinch weld with (2) M6x1-25mm Hex Bolts, (4) M6 Large Flat Washers and (2) M6 Nylon Lock Nuts, (Fig 6). Do not fully tighten hardware at this time.

IMPORTANT: Some models are not equipped with factory holes and will **require drilling** through the pinch weld to attach the Support Bracket. Do not drill through pinch weld at this time, (Refer to **Step 7**).

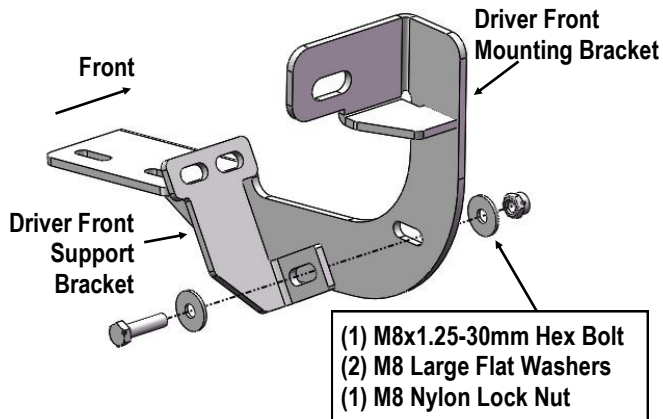

(Fig 5) Driver Front Mounting Bracket Assembly

- (2) M6x1-25mm Hex Bolts
- (4) M6 Large Flat Washers
- (2) M6 Nylon Lock Nuts

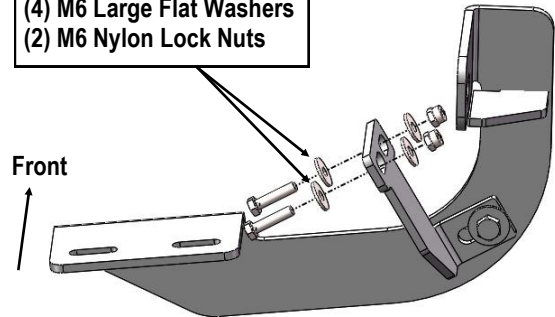

(Fig 6) Driver Front Support Bracket Installed

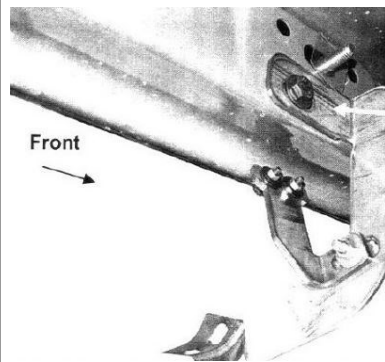

Models without factory threaded inserts in body panel:

- (1) M10X1.5-40 Hex Bolt
- (1) M10 Flat Washer
- (1) M10 Lock Washer

Models with factory threaded inserts:

- (1) M8x1.25-30 Hex Bolt
- (1) M8 Lock Washers
- (1) M8 Large Flat Washer

(Fig 7) Driver Side Front Mounting Bracket Installation

STEP 5

Move along the side of the body panel to the Driver Side Rear Mounting Location.

Models without factory threaded inserts on body panel:

Select (1) M10 Bolt/Nut Plate, repeat **Step 2** to install the M10 Bolt/Nut Plate into the oval hole (Fig 8).

Insert (1) M10 Rivet Nut into the hole on rocker panel, and attach the Rear Bracket onto the installed M10 Bolt/Nut Plate temporarily with (1) M10 Hex Nut, (1) M10 Flat Washer, (1) M10 Lock Washer. And use the mounting bracket as a tool to secure the M10 Rivet Nut onto the rocker panel with (1) M10X1.5-30mm Hex Bolt, (1) M10 Large Flat Washer and (1) M10 Lock Washer, (Fig 9). After the M10 Rivet Nut installed,

iBoard®

remove the M10 hardware from the center hole of the mounting bracket, (Fig 9).

And then Attach the Driver Rear Mounting Bracket on the installed M10 Rivet Nut and M10 Bolt Nut/Plate, (Fig 9).

Models with factory threaded inserts, (Fig 4):

Attach the Driver Rear Mounting Bracket onto the factory threaded insert with (2) M8X1.25-30mm Hex Bolt, (2) M8 Lock Washer, (2) M8 Large Flat Washer (Fig 10). Do not fully tighten hardware at this time.

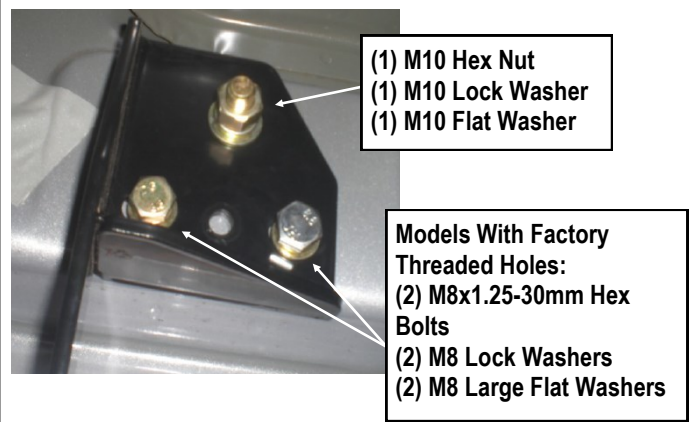

(Fig 10) Driver Rear Mounting Bracket Installed

STEP 6

Select a Running Board. Slip (2) M6x1-20mm Square Head Bolts into each bottom channel (Fig 11). Carefully position the Running Board onto the (2) Mounting Brackets.

IMPORTANT: Do not slide the Running Board on the Brackets or the bottom surface of the board will be damaged. Attach the Running Board to each Mounting Bracket with (2) M6x1-20mm Square Head Bolts, (2) M6 Large Flat Washers and (2) M6 Nylon Lock Nuts (Fig 12). Do not fully tighten at this time.

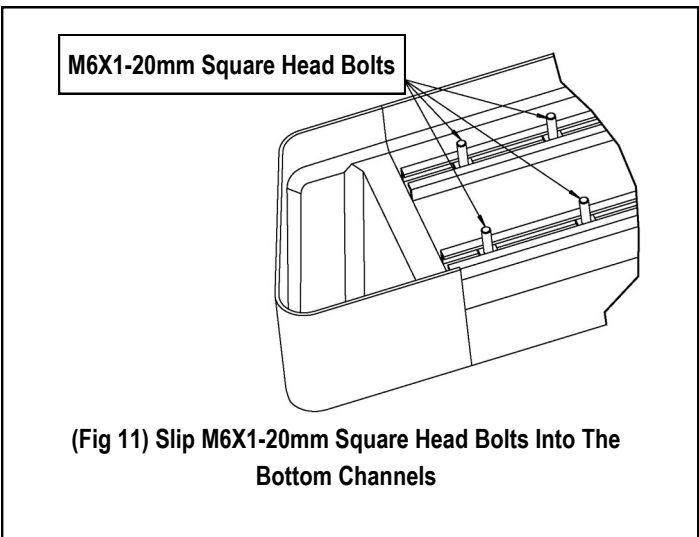

(Fig 11) Slip M6X1-20mm Square Head Bolts Into The Bottom Channels

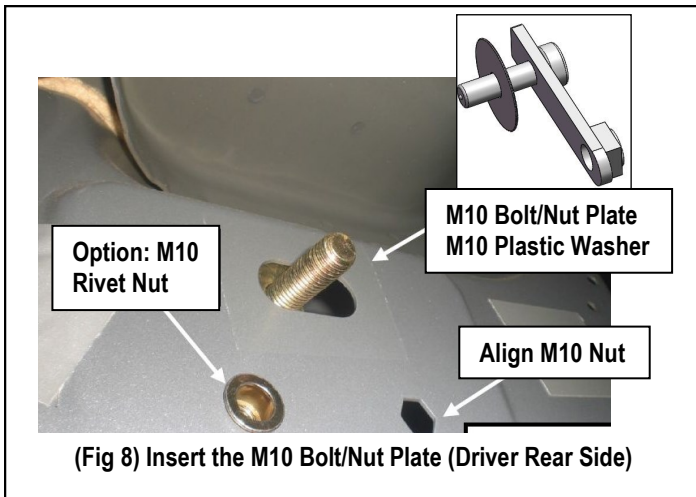

(Fig 8) Insert the M10 Bolt/Nut Plate (Driver Rear Side)

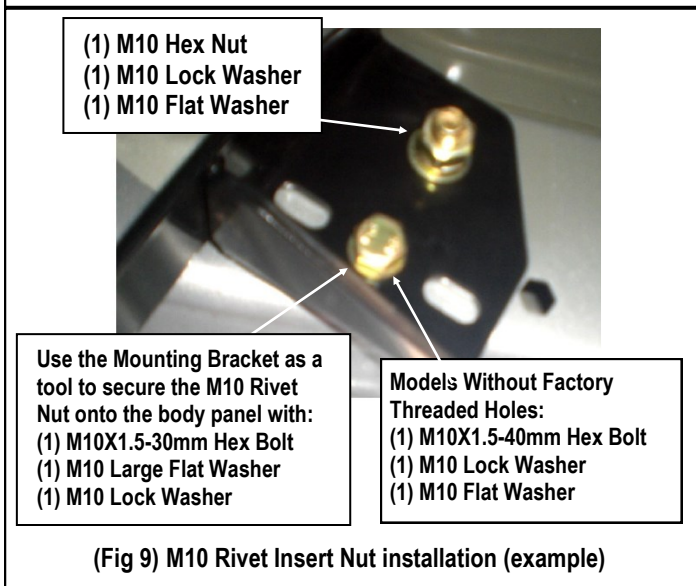

(Fig 9) M10 Rivet Insert Nut installation (example)

iBoard®

- (2) M6X1-20mm Square Head Bolts
- (2) M6 Large Flat Washers
- (2) M6 Nylon Lock Nuts

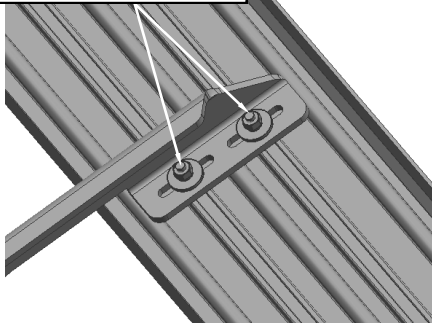

(Fig 12) Running Board Installed Onto Mounting Bracket

STEP 7

Some Models requiring **drilling** for Driver Front Support Bracket:

- Make sure the sidebar is level to the vehicle. Line up the slot on the Support Bracket with the back of the pinch weld. Mark the location of the slot onto the pinch weld.
- Drill (2) $\frac{1}{4}$ " holes through the pinch weld. **Important:** Do not drill too close to the bottom edge of the pinch weld. Drill the holes toward the outside of the marked slot.
- Attach the Support Bracket to the pinch weld with (2) M6 X1-25mm Hex Bolts, (4) M6 Large Flat Washers, (2) M6 nylon Lock Nuts. (Fig 7).
- Check for level then fully tighten all hardware.

STEP 8

Level and adjust the Running Board and fully tighten all hardware.

Important: Please follow the recommended Tightening Torques shown in the table on page 1. Don't over tighten, or the nuts/bolts will be damaged.

STEP 9

Repeat **Steps 1-8** for the other side Running Board installation. The installation is completed .

Attention

Do periodic inspections to the installation to make sure that all hardware is secure and tight.

In order to protect your bars/boards, please use only mild soap/non-abrasive products for cleaning.