

iBoard®



Scan for
Installation Video

iBoard® by APS

PART#: IB-P912C&J

READ INSTRUCTIONS CAREFULLY BEFORE STARTING INSTALLATION. REMOVE CONTENTS FROM BOX AND VERIFY ALL PARTS ARE PRESENT. ASSISTANCE IS RECOMMENDED.

*ROCKER PANEL MOUNT
*NO DRILLING REQUIRED

Fastener Size	Tightening Torque (ft-lbs)	Required
6mm	6-7	X
8mm	16-18	√
10mm	31-32	√
12mm	56-58	X
14mm	92-94	X

PART LIST

Driver Side Step Bar

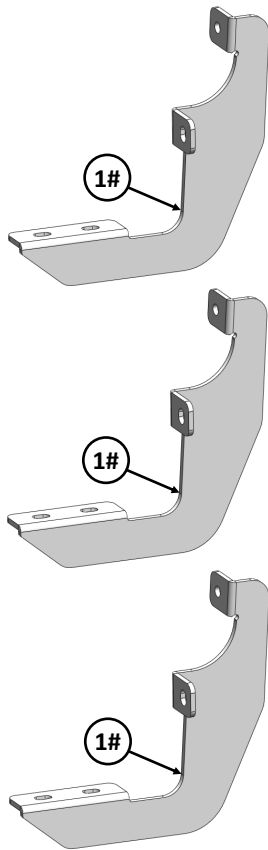

Front



Passenger Side Step Bar

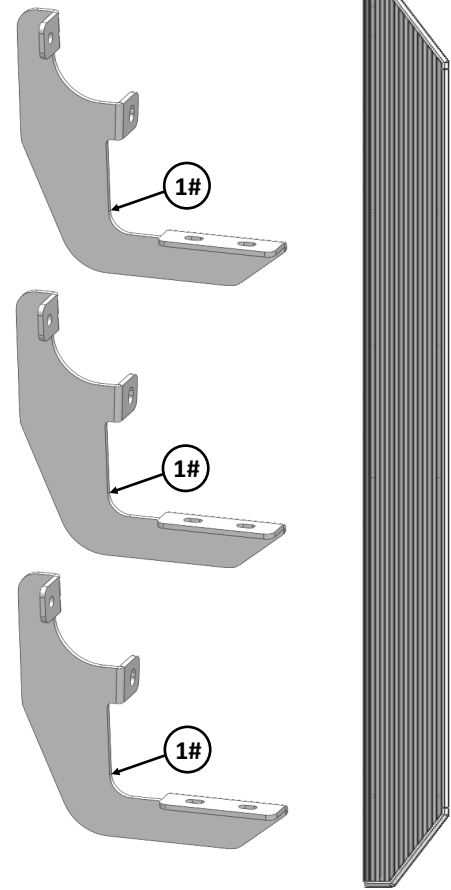





Customer Support: info@iboardauto.com



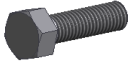



Scan for
Installation Video

Hardware Package A (For Bracket Installation)					
Item	QTY	Description	Item	QTY	Description
1#	6	Mounting Brackets	5#	12	M10 Lock Washers
2#	6	M10X35 Bolt Plates	6#	6	M10 Hex Nuts
3#	6	M10X1.5-25mm Hex Bolts	7#	6	M10 Rivet Nuts
4#	12	M10 Flat Washers			

					
2 #	3 #	4 #	5 #	6 #	7 #

Hardware Package B (For Step Bar Installation)					
Item	QTY	Description	Item	QTY	Description
1#	12	M8X1.25-35mm Carriage Bolts	3#	12	M8 Nylon Lock Nuts
2#	12	M8 Large Flat Washers	4#	6	Sliders (Packed with Mounting Brackets)

			
1 #	2 #	3 #	4 #

iBoard®



Scan for
Installation Video

STEP 1

Start installation from the driver side of the vehicle. Separate trim from rocker panel and insert M10x35 Bolt Plate as shown. Do not fully tighten at this time, **(Fig 1 & 2)**.

Insert M10 Rivet Nuts as shown. **(Fig 2)**.

STEP 2

Attach (1) Mounting Bracket with (1) M10X1.5-25mm Hex Bolt, (2) M10 Flat Washers, (2) M10 Lock Washers and (1) M10 Hex Nut, **(Fig 3)**. Do not fully tighten hardware at this time.

Tighten top bolt to crimp Rivet Nut until increased resistance is felt. Verify M10 Rivet Nut is not loose in hole, otherwise re-tighten. Hole M10x35 Bolt Plate parallel to rocker panel and tighten bottom nut. Re-attach trim panel as shown, **(Fig 4)**.

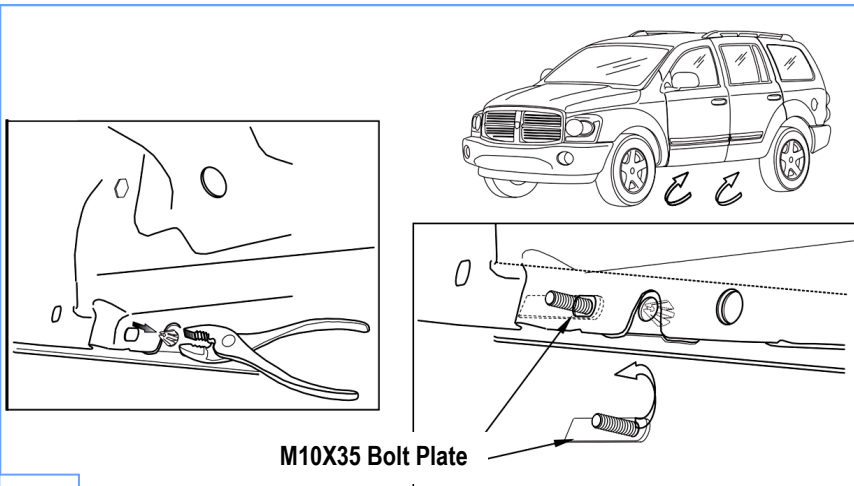

Fig 1

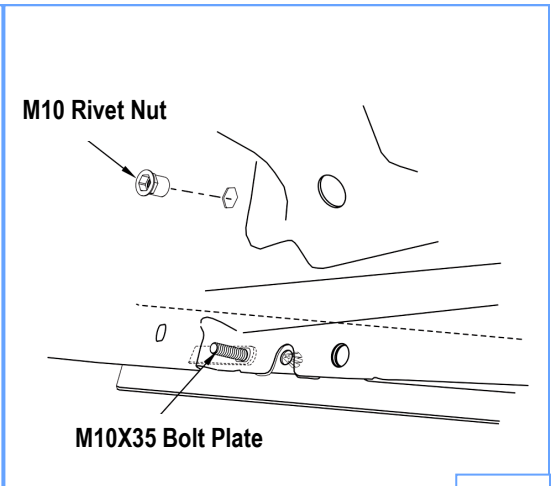
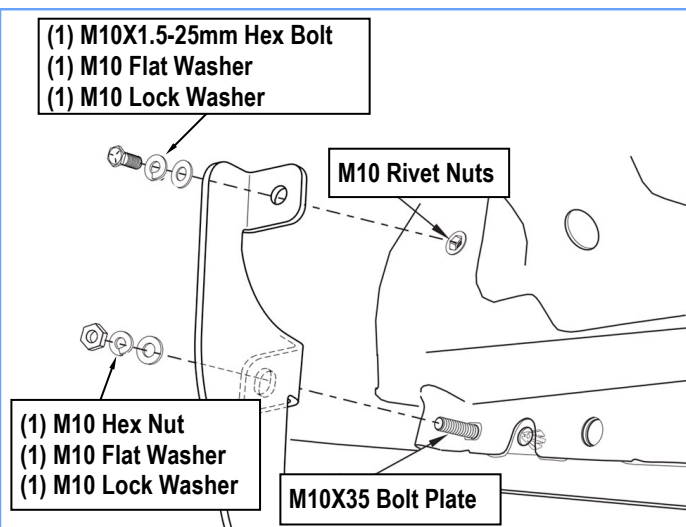
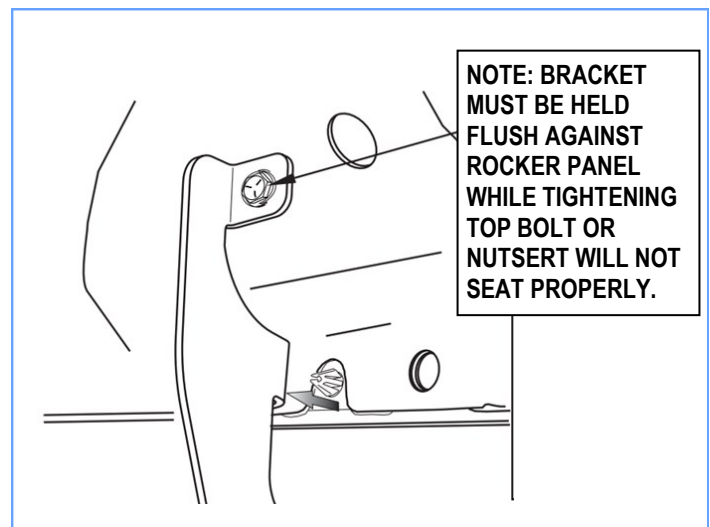

Fig 2



(Fig 3) Driver Front Mounting Bracket Installation



(Fig 4) Re-attach Trim Panel As Shown



STEP 3

Move to the driver side center & rear of the vehicle. Repeat **Steps 1-2** for other (2) Mounting Brackets installation.

Note: (6) Mounting Brackets are universal.

STEP 4

Once all (3) Driver side mounting brackets are assembled, then proceed to the Step Bar installation. (**Figs 5 & 6**)

- (1) Select (1) Slider and (2) M8X1.25-35mm Carriage Bolts;
- (2) Install (2) M8X1.25-35mm Carriage Bolts in (1) Slider.
- (3) Slide the Slider (with carriage bolts) to the **Step Bar**.
- (4) Repeat to install the other (2) sliders to the step bar.
- (5) Attach the Step Bar (with the Sliders) onto the installed

mounting brackets. Position the Sliders to the installed brackets. Secure the Step Bar to the installed Brackets by using (6) M8 Large Flat Washers and (6) M8 Nylon Lock Nuts and (3) Sliders, (**Fig 6**). Do not fully tighten hardware at this time.

Note: The Sliders are packed with the Mounting Brackets.

Level and adjust the Step Bar and fully tighten all hardware.

Repeat **Steps 1-4** for the other side Step Bar installation. **The installation is completed!!!**

Attention

Do periodic inspections to the installation to make sure that all hardware is secure and tight.

In order to protect your bars/boards, please use mild soap/non-abrasive products for cleaning only.

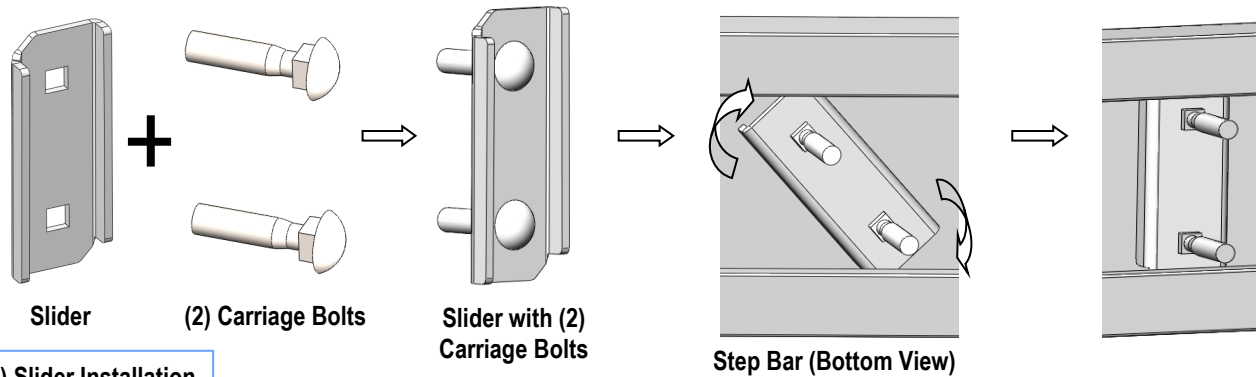

(Fig 5) Slider Installation

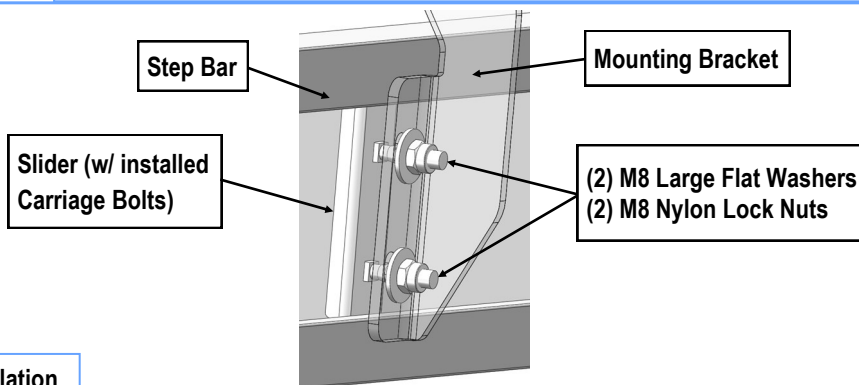

(Fig 6) Step Bar Installation