

iBoard®

iBoard® by APS

PART#: IB-065A-B

READ INSTRUCTIONS CAREFULLY BEFORE STARTING INSTALLATION. REMOVE CONTENTS FROM BOX AND VERIFY ALL PARTS ARE PRESENT. ASSISTANCE IS RECOMMENDED.

*BODY FRAME MOUNT
*NO DRILLING REQUIRED

Fastener Size	Tightening Torque (ft-lbs)
6mm	6-7
8mm	16-18
10mm	31-32
12mm	56-58
14mm	92-94

PART LIST

Front



Driver Front Mounting Bracket (DFM)

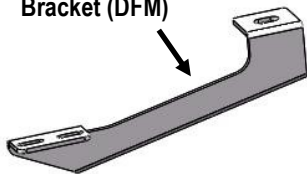

Passenger Front Mounting Bracket (PFM)

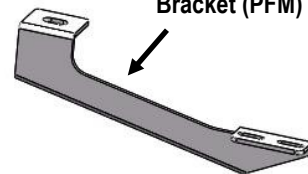

Driver Center Mounting Bracket (DCM)

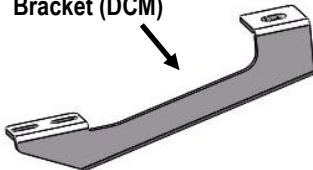

Passenger Center Mounting Bracket (PCM)

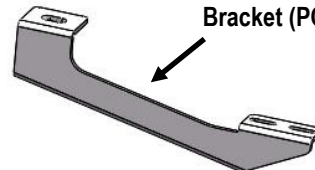

Driver Rear Mounting Bracket (DRM)

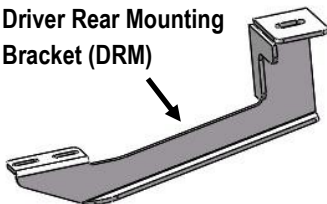

Passenger Rear Mounting Bracket (PRM)

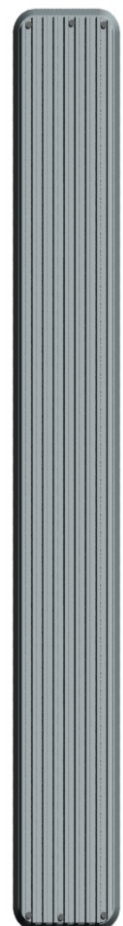
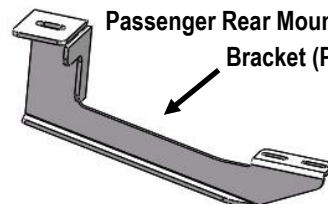

Customer Support: info@iboardauto.com

iBoard®



X6

M12X1.75-120mm Hex Bolt



X6

M12 Flat Washer



X6

M12 Lock Washer



X12

M6X1-20mm Square Head Bolt



X12

M6 Large Flat Washer



X12

M6X1 Nylon Lock Nut

STEP 1

Start installation from the passenger side of the vehicle. Remove the body mount bolts from body mounts.

Select the Passenger Front Mounting Bracket (**PFM**), Passenger Center Mounting Bracket (**PCM**) and Passenger Rear Mounting Bracket (**PRM**). Bolt the (3) mounting brackets to the vehicle with (3) M12X1.75-120mm Hex Bolts, (3) M12 Lock Washers and (3) M12 Flat Washers (**Fig 1**). Do not fully tighten hardware at this time.

STEP 2

Select a Running Board. Slip (3) M6x1-20mm Square Head Bolts into each bottom channel (**Fig 2**). Carefully position the Running Board onto the (3) Mounting Brackets.

IMPORTANT: Do not slide the Running Board on the Brackets or the bottom surface of the board will be damaged. Attach the Running Board to Mounting Bracket with (6) M6x1-20mm Square Head Bolts, (6) M6 Large Flat Washers and (6) M6 X1 Nylon Lock Nuts (**Fig 3**). Do not fully tighten hardware at this time.

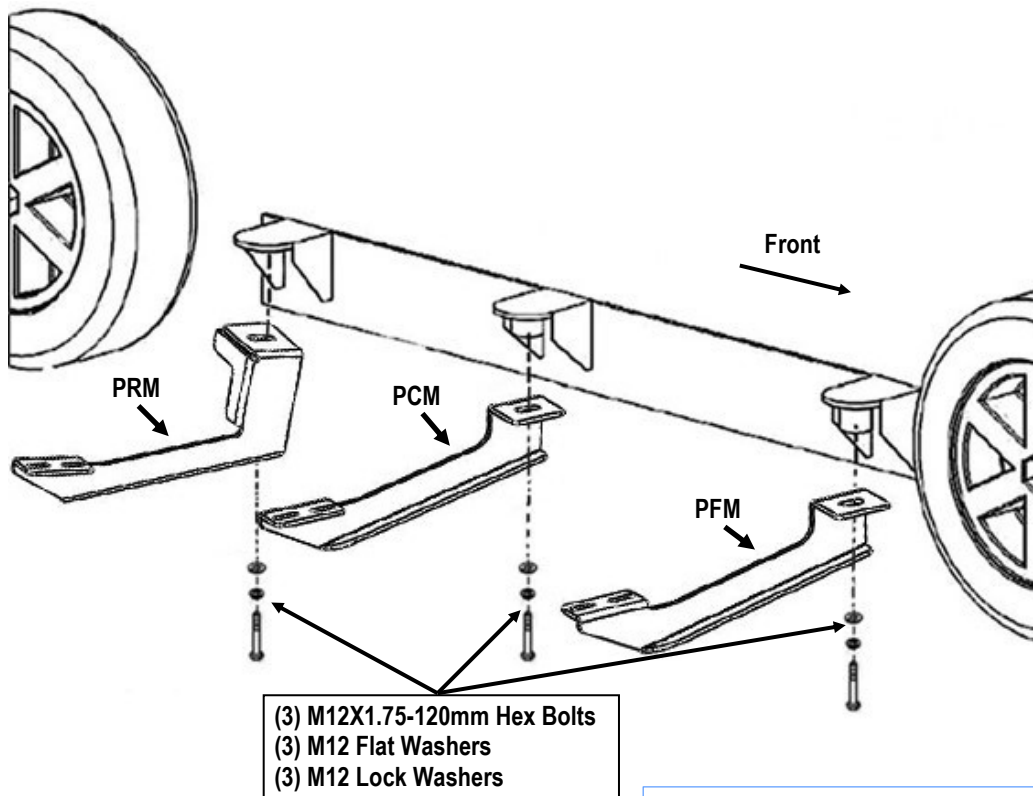

(Fig 1) Passenger Side Mounting Brackets Installation

iBoard®



(Fig 2) Slip M6X1-20mm Square Head Bolts Into The Bottom Channels

- (2) M6X1-20mm Square Head Bolts
- (2) M6 Large Flat Washers
- (2) M6X1 Nylon Lock Nuts

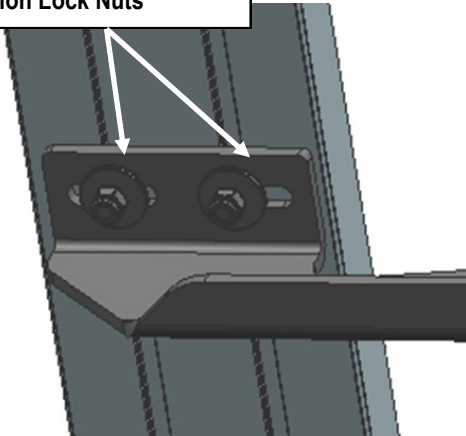

(Fig 3) Running Board Installed Onto the Mounting Bracket (Example)

STEP 3

Level and adjust the Running Board and fully tighten all hardware.

STEP 4

Repeat **Steps 1-3** for the other side Running Board installation. The installation is completed, (Fig 4).



(Fig 4) Installation Completed

Attention

Do periodic inspections to the installation to make sure that all hardware is secure and tight.

In order to protect your bars/boards, please use only mild soap/non-abrasive products for cleaning.