



## iBoard® by APS

PART#: IB-401C&H

READ INSTRUCTIONS CAREFULLY BEFORE STARTING INSTALLATION. REMOVE CONTENTS FROM BOX AND VERIFY ALL PARTS ARE PRESENT. ASSISTANCE IS RECOMMENDED.

\*ROCKER PANEL MOUNT  
\*DRILLING IS REQUIRED

Fastener Size	Tightening Torque (ft-lbs)	Required
6mm	6-7	X
8mm	16-18	√
10mm	31-32	X
12mm	56-58	X
14mm	92-94	X

### PART LIST

#### Driver Side Step Bar

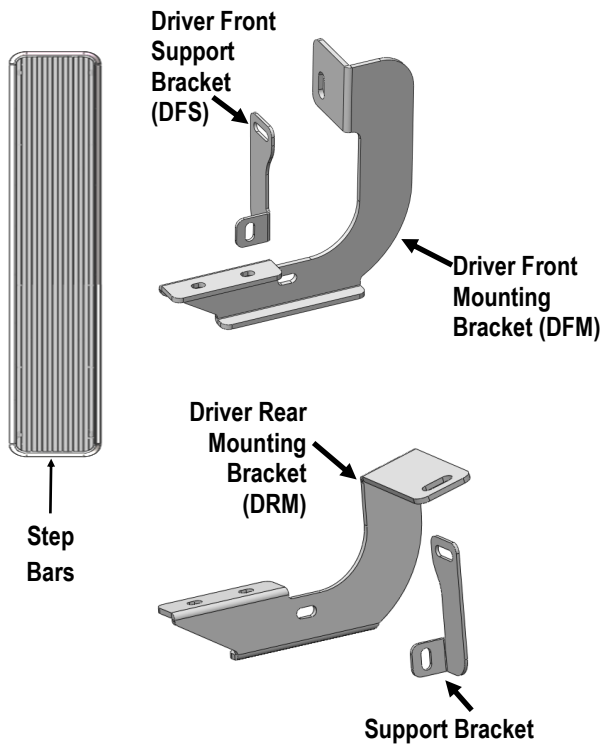

#### Front

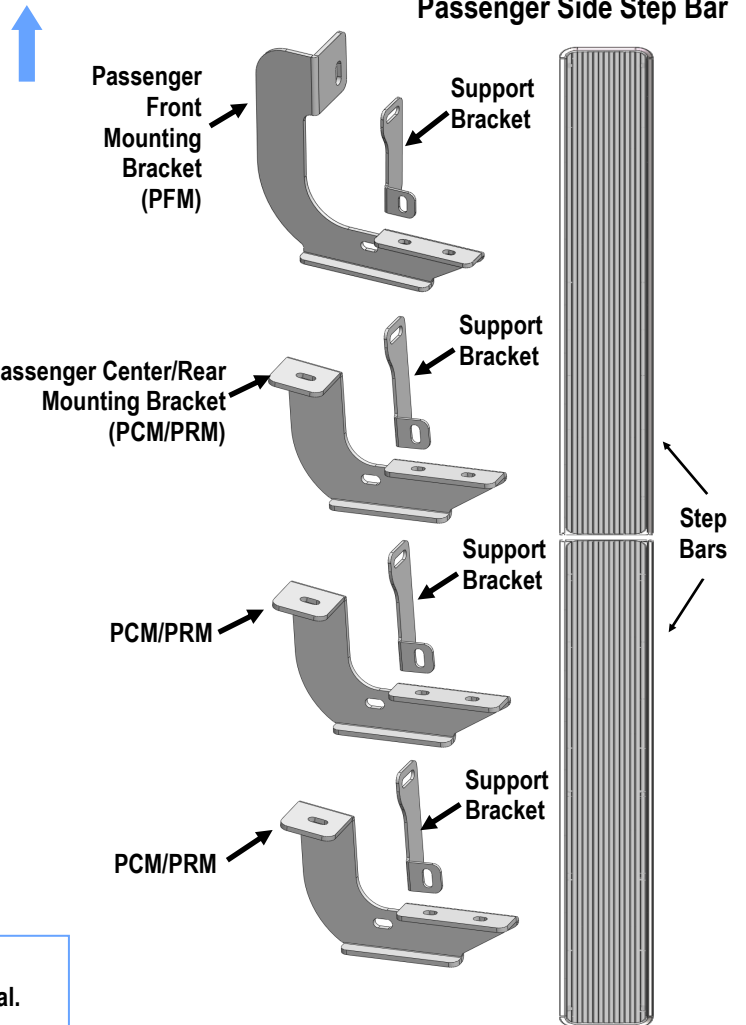

Note: \*(5) Support Brackets are universal.  
\*(3) Passenger Center/Rear Mounting Brackets are universal.





Hardware Package A (For Bracket Installation)					
Item	QTY	Description	Item	QTY	Description
1#	6	M8 Bolt Plates	5#	24	M8 Flat Washers
2#	6	M8 Plastic Washers	6#	6	M8 Lock Washers
3#	12	M8X1.25-25mm Hex Bolts	7#	6	M8 Hex Nuts
4#	6	M8 Large Flat Washers	8#	12	M8X1.25 Nylon Lock Nuts

  
1#

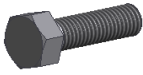
  
2#

  
3#

  
4#

  
5#

  
6#

  
7#

  
8#

Hardware Package B (For Stainless Steel Step Bar Installation)					
Item	QTY	Description	Item	QTY	Description
1#	12	M8X1.25-35mm Carriage Bolts	3#	12	M8 Nylon Lock Nuts
2#	12	M8 Large Flat Washers	4#	6	Sliders (Packed with Step Bars)

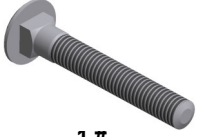
  
1 #

  
2 #

  
3 #

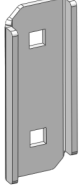
  
4 #

Hardware Package C (For Stainless Steel Step Bar Assembly)					
Item	QTY	Description	Item	QTY	Description
1#	4	Plastic Rivets	5#	2	M8 Hex Nuts
2#	6	M8X1.25-25mm Inner Hex Bolts	6#	1	Plastic Cover (Packed with Step Bars)
3#	8	M8 Flat Washers	7#	1	Back Plate (Packed with Step Bars)
4#	6	M8 Lock Washers			

  
1 #

  
2 #

  
3 #

  
4 #

  
5#

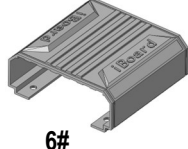
  
6#

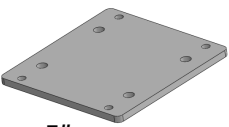
  
7#



## STEP 1

### Passenger Side Step Bar Assembly:

1. Select and assemble (2) Step Bars with (2) M8X1.25-25mm Inner Hex Bolts, (4) M8 Flat Washers, (2) M8 Lock Washers and (2) M8 Hex Nuts, (Fig 1). **NOTE: (2) Step Bars are universal.**
2. Attach (1) Back Plate to the bottom of the installed (2) Step Bars with (4) M8X1.25-25mm Inner Hex Bolts, (4) M8 Flat Washers, (4) M8 Lock Washers, (Fig 2).
3. Install (1) Plastic Cover to cover the joint of (2) Step bars with (4) Plastic Rivets, (Fig 3).

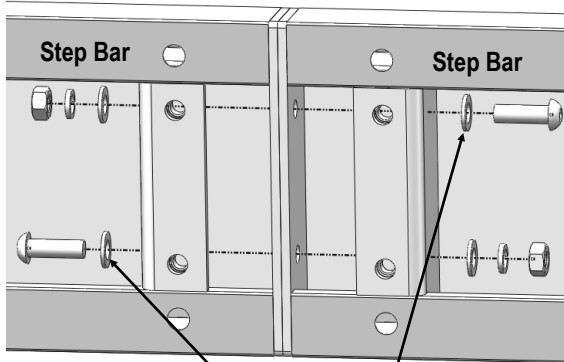

(2) M8X1.25-25mm Inner Hex Bolts  
(4) M8 Flat Washers  
(2) M8 Lock Washers  
(2) M8 Hex Nuts

(Fig 1) Step Bars Assembly

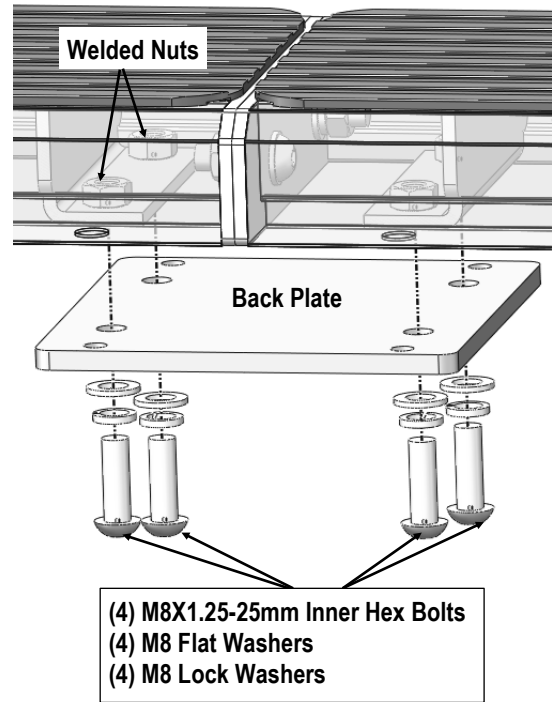

(4) M8X1.25-25mm Inner Hex Bolts  
(4) M8 Flat Washers  
(4) M8 Lock Washers

(Fig 2) Back Plate Installation

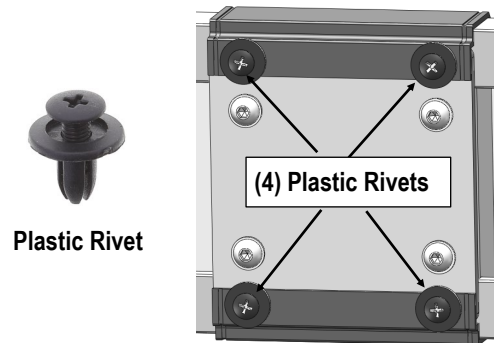

(Fig 3) Plastic Cover Installation (Bottom View)

### Assembled Passenger Side Step Bar





## STEP 2

Starting installation from the driver side front of the vehicle. Locate the factory hole on the inner side of the body panel, (**Fig 4A & 4B**).

**IMPORTANT:** Holes may be covered with rubber plug, sealing tape and/or heavy undercoating. Remove undercoating from all mounting locations so that Brackets can be installed flatly against body panel and pinch weld.

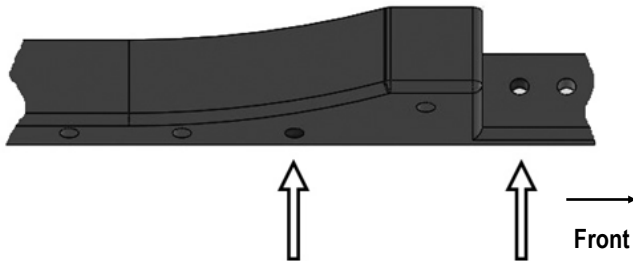

(Fig 4A) Driver Side Front & Rear Mounting Locations

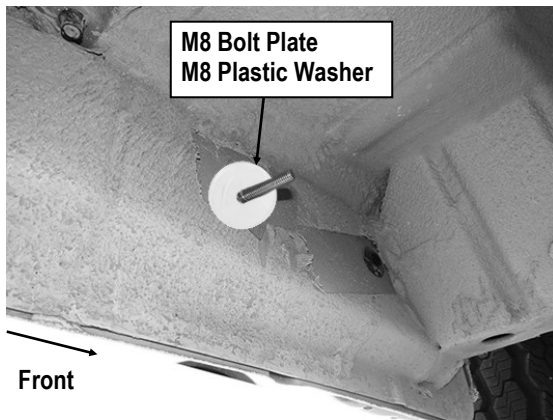

(Fig 4B) Driver Side Front Mounting Location

## STEP 3

Select (1) M8 Bolt Plate and (1) M8 Plastic Washer. Thread the M8 Plastic Washer part way onto the M8 Bolt Plate. Insert the M8 Bolt Plate into the hole and tighten the M8 Plastic Washer against the body panel, (**Fig 4B**).

**IMPORTANT:** The M8 Plastic Washer is designed to hold the M8 Bolt Plate in place during Bracket installation.

## STEP 4

Select the Driver Front Mounting Bracket (**DFM**) and the Driver Front Support Bracket (**DFS**). Attach the Support Bracket to the front of the Mounting Bracket with (1) M8X1.25-25mm Hex Bolt, (2) M8 Flat Washers and (1) M8 Nylon Lock Nut, (**Fig 5**). Do not fully tighten hardware at this time.

**Note:** Driver Front Support Bracket (**DFS**) are different with the other (5) Support Brackets.

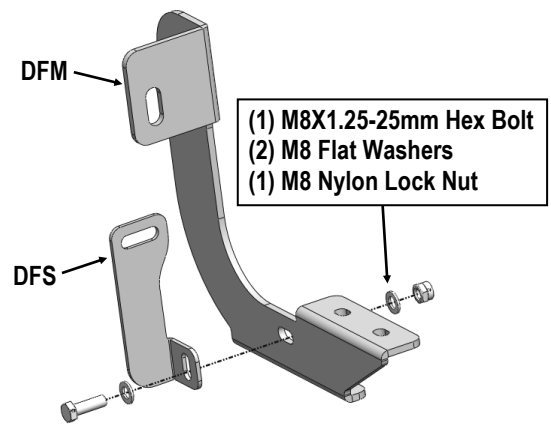

(Fig 5) Driver Front Mounting Brackets Assembly

## STEP 5

Attach the Driver Front Mounting Bracket (**DFM**) to the installed M8 Bolt Plate with (1) M8 Large Flat Washer, (1) M8 Lock Washer and (1) M8 Hex Nut, (**Fig 6**). Do not fully tighten hardware at this time.

Line up the top of the Support Bracket with the outside of the pinch weld.

## STEP 6

Move to the driver side rear mounting location. Locate the factory hole in the bottom of the floor panel, (**Fig 7**). Repeat **Steps 2-5** to assemble and install the Driver Rear Mounting Bracket (**DRM**) and Support Bracket, (**Fig 8**).

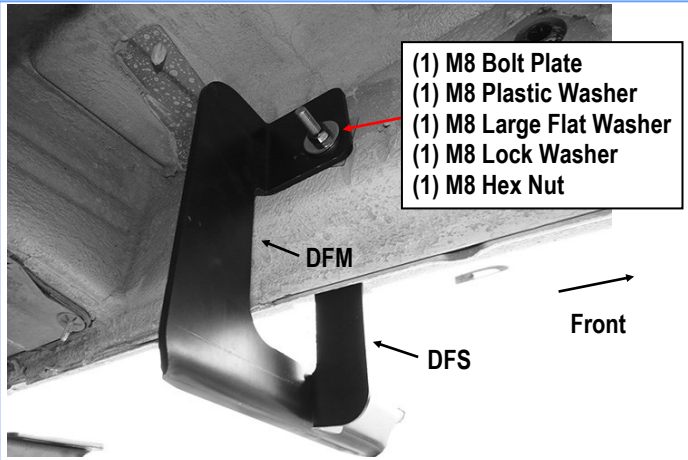

(Fig 6) Driver Front Mounting Bracket (DFM) Installation

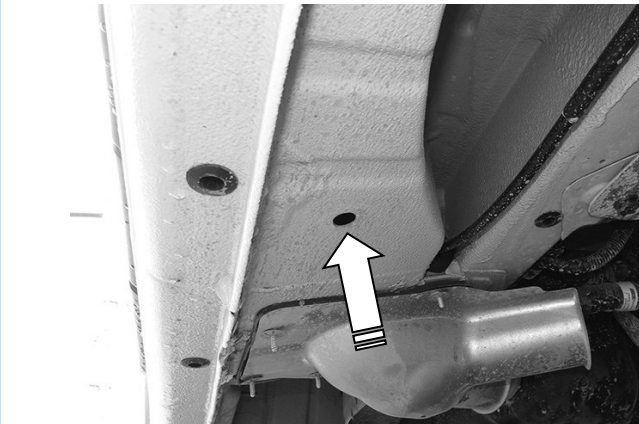

(Fig 7) Driver Side Rear Mounting Location

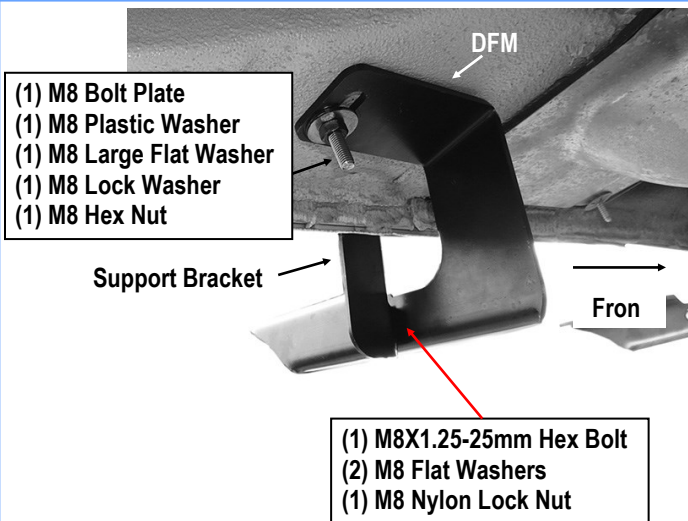

(Fig 8) Driver Rear Mounting Bracket (DRM) Installation

## STEP 7

Once all (2) Driver side mounting brackets are installed, then proceed to the Step Bar installation. (Figs 9 & 10)

- (1) Select (1) Slider and (2) M8X1.25-35mm Carriage Bolts;
- (2) Install (2) M8X1.25-35mm Carriage Bolts in (1) Slider.
- (3) Slide the Slider (with carriage bolts) to the **Step Bar**.
- (4) Repeat to install the other (1) slider to the step bar.
- (5) Attach the Step Bar (with the Sliders) onto the installed mounting brackets. Position the Sliders to the installed brackets. Secure the Step Bar to the installed Brackets by using (4) M8 Large Flat Washers and (4) M8 Nylon Lock Nuts and (2) Sliders, (Fig 10). Do not fully tighten hardware at this time.

**Note:** The Sliders are packed with the Step Bars.

## STEP 8

Adjust the (2) Support Brackets, attach the Brackets to the outside of the pinch weld. Mark the location of the (2) slots in the Support Brackets onto the pinch weld, (Fig 11). Drill (2) 5/16" through holes on the pinch weld for the front and rear Support Brackets, (Fig 11).

**NOTE:** Drill the holes as far away from the bottom edge of the pinch weld as possible. **IMPORTANT:** Do not drill on the welds on the pinch weld if possible.

**IMPORTANT!** Any cutting or drilling tool may break or shatter. Government regulations require safety glasses & equipment at all times when cutting or drilling.

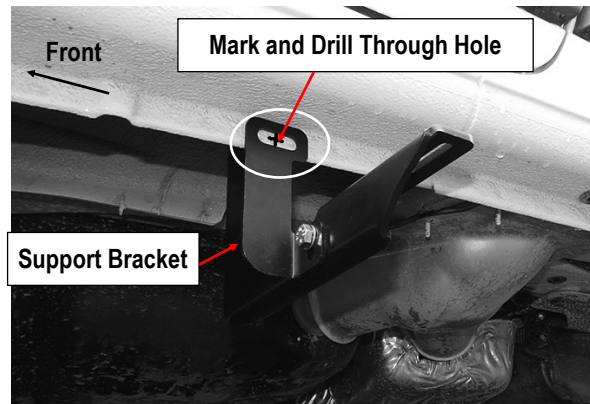

(Fig 11) Mark and Drill Through Holes on Pinch Weld



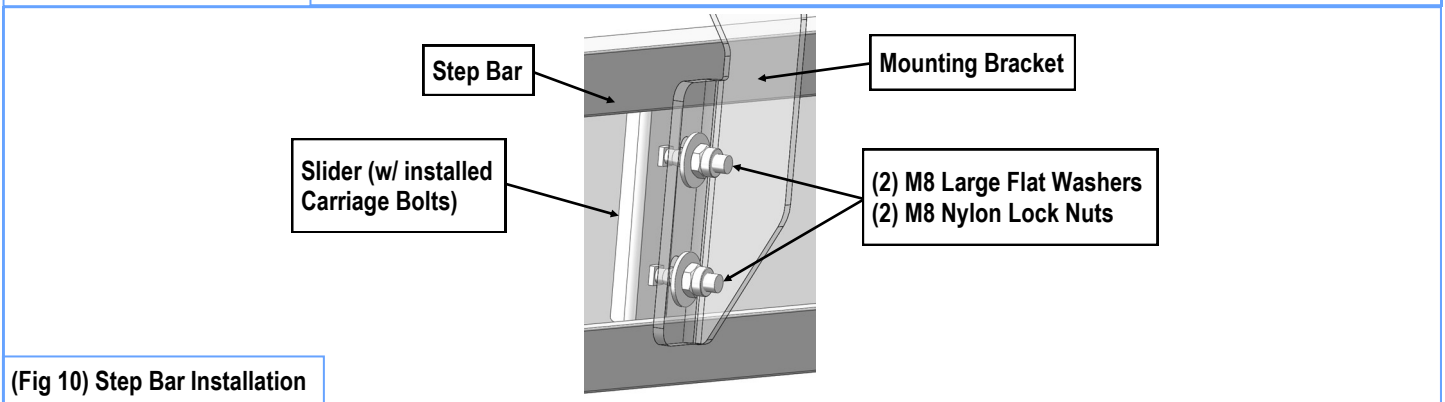
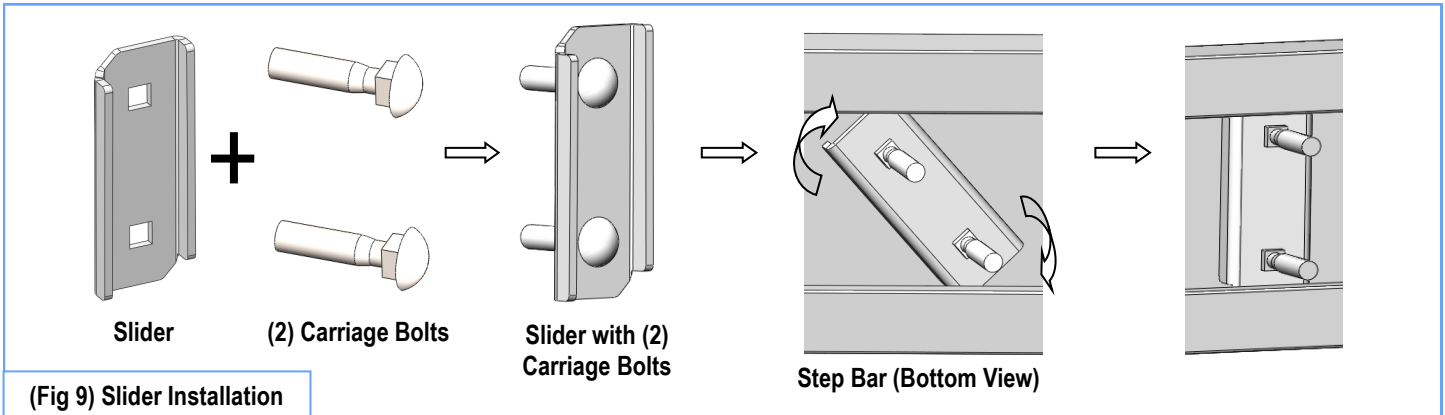

## STEP 9

Secure the each Support Bracket to the outside of the pinch weld with (1) M8X1.25-25mm Hex Bolt, (2) M8 Flat Washers and (1) M8 Nylon Lock Nut, (Fig 12). Reinstall the Running Board. Level, adjust and tighten all hardware.

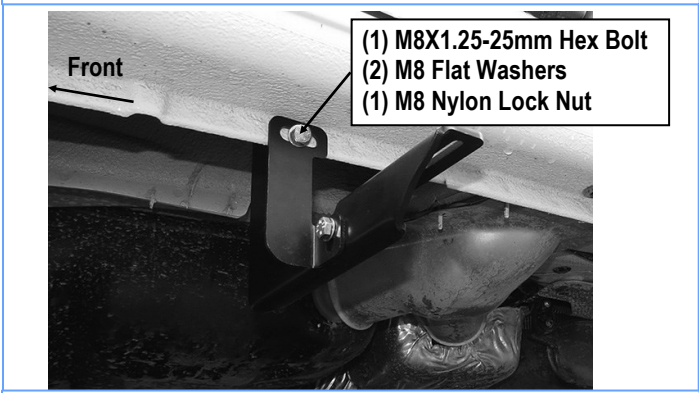

(Fig 12) Driver Side Support Bracket Installed on Pinch Weld

## STEP 10

Move to the passenger side front of the vehicle, (Fig 13A & 13B). Repeat Steps 2-5 to assemble and install the Passenger Front Mounting Bracket (PFM) and the Support Bracket, (Fig 14).

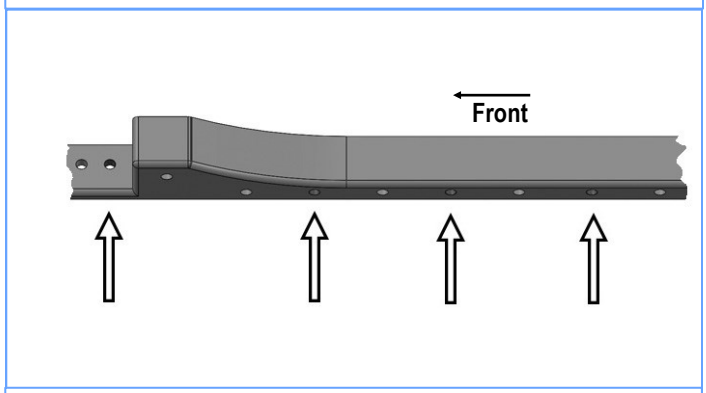

(Fig 13A) Passenger Side Mounting Bracket Locations

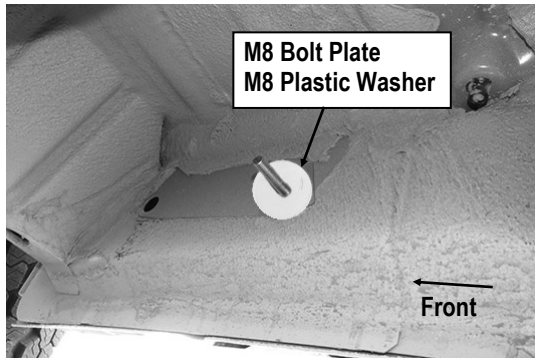

(Fig 13B) Passenger Side Front Mounting Location

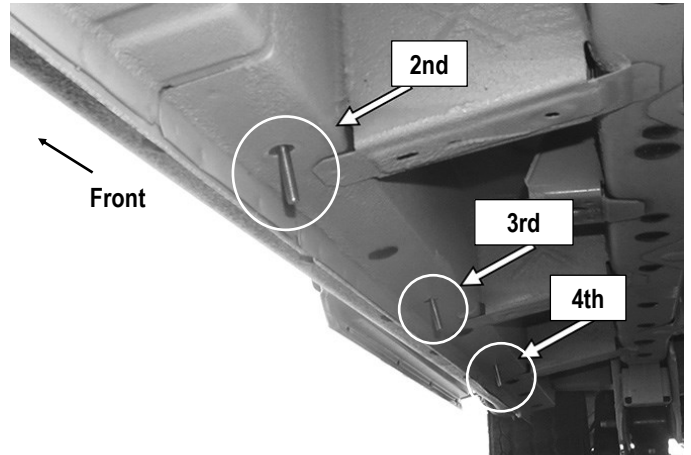

(Fig 15) Passenger Side 2nd & 3rd & 4th Mounting Locations

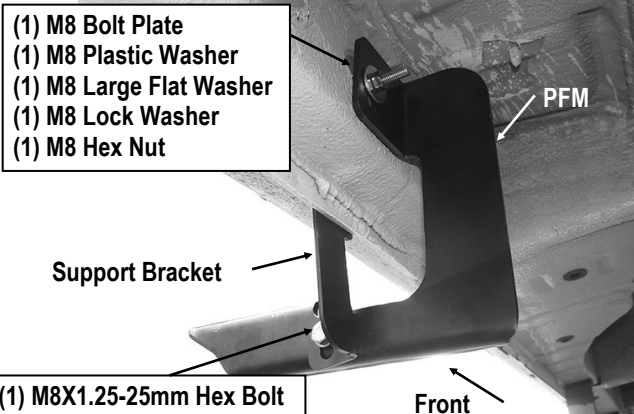

(Fig 14) Passenger Side Front Brackets Installation

## STEP 11

Continue to the 2nd & 3rd & 4th mounting locations, (Fig15). Repeat **Steps 2-5** to install and assemble the Mounting Brackets and the Support Brackets.

**Note:** Passenger Side 2nd & 3rd & 4th Mounting Bracket are universal.

## STEP 12

Select the Passenger Side Step Bar. Repeat **Step 7** to attach the Step Bar to (4) Mounting Brackets. Do not fully tighten hardware at this time.

## STEP 13

Adjust the locations of (4) support brackets, repeat **Step 8** to mark and drill holes on pinch weld. Repeat **step 9** to secure the (4) Support Brackets to the outside of pinch weld, (Figs 16-17).

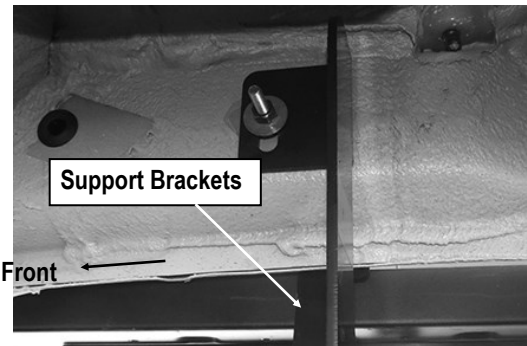

(Fig 16) Passenger Front Support Bracket Location on Pinch Weld

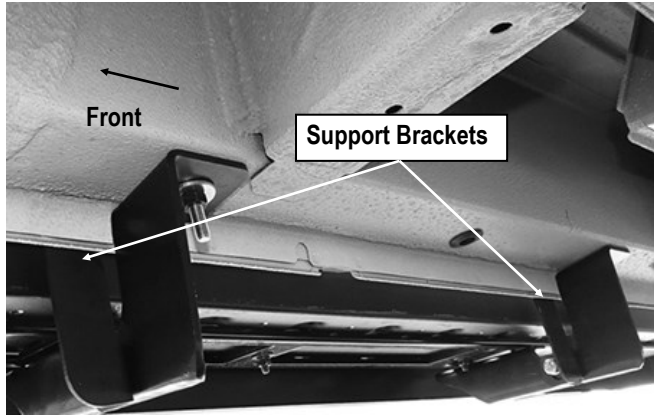

(Fig 17) Passenger 2nd & 3rd Support Brackets Locations on Pinch Weld

## STEP 14

Level and adjust the Step Bar and fully tighten all hardware.  
**Installation completed!**

### Attention

Do periodic inspections to the installation to make sure that all hardware is secure and tight.

In order to protect your bars/boards, please use mild soap/non-abrasive products for cleaning only.