



iBoard® by APS

PART#: IB-361C&H

READ INSTRUCTIONS CAREFULLY BEFORE STARTING INSTALLATION. REMOVE CONTENTS FROM BOX AND VERIFY ALL PARTS ARE PRESENT. ASSISTANCE IS RECOMMENDED.

*ROCKER PANEL MOUNT
*NO DRILLING REQUIRED

Fastener Size	Tightening Torque (ft-lbs)	Required
6mm	6-7	X
8mm	16-18	√
10mm	31-32	√
12mm	56-58	X
14mm	92-94	X

PART LIST

Driver Side Step Bar

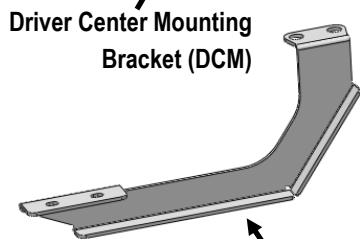
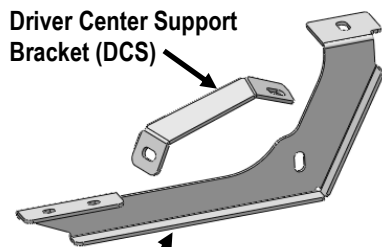
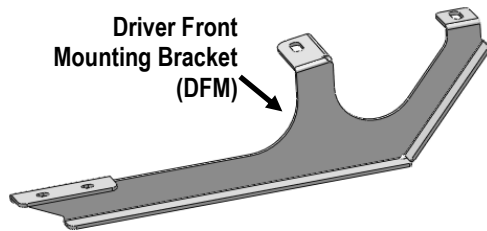
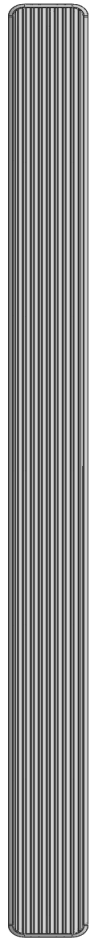

Front



Passenger Side Step Bar

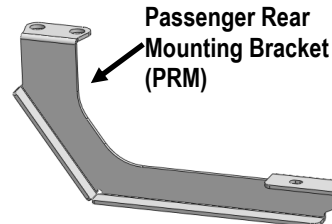
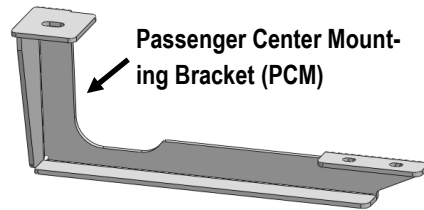
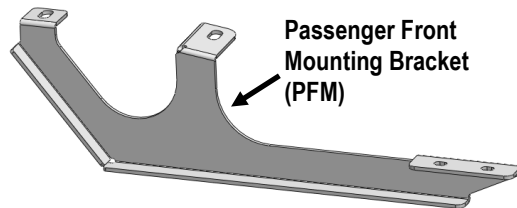
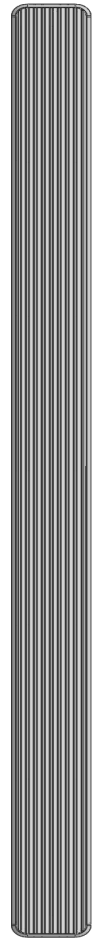



Hardware Package A (For Bracket Installation)

Item	QTY	Description	Item	QTY	Description
1#	5	M10 L Bolt Plates	5#	9	M10 Flat Washers
2#	2	M10 T Bolt Plates	6#	8	M10 Lock Washers
3#	7	M10 Plastic Washers	7#	8	M10 Hex Nuts
4#	1	M10X1.5-30mm Hex Bolts			

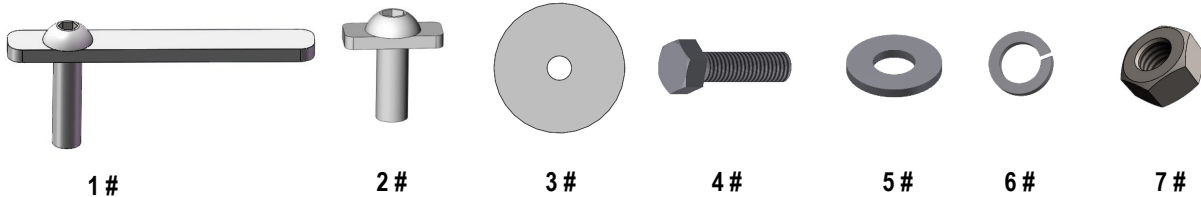

Hardware Package B (For Stainless Steel Step Bar Installation)

Item	QTY	Description	Item	QTY	Description
1#	12	M8X1.25-35mm Carriage Bolts	3#	12	M8 Nylon Lock Nuts
2#	12	M8 Large Flat Washers	4#	6	Sliders (Packed with Step Bars)

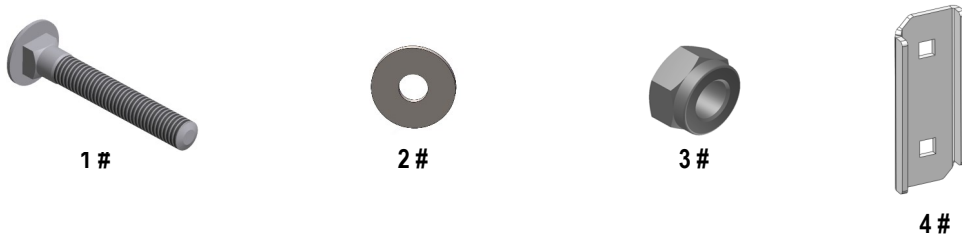



STEP 1

Start installation from the passenger side front of the vehicle. Locate the factory holes at the bottom of the floor panel, (**Fig 1**). **NOTE:** The mounting locations may be covered by sealant or undercoating. Use a small screwdriver to poke through the sealant to uncover the hole.

IMPORTANT: Brackets must sit flat against sheet metal. If necessary, remove the sealant or undercoating covering the mounting locations on body panel before installing Brackets.

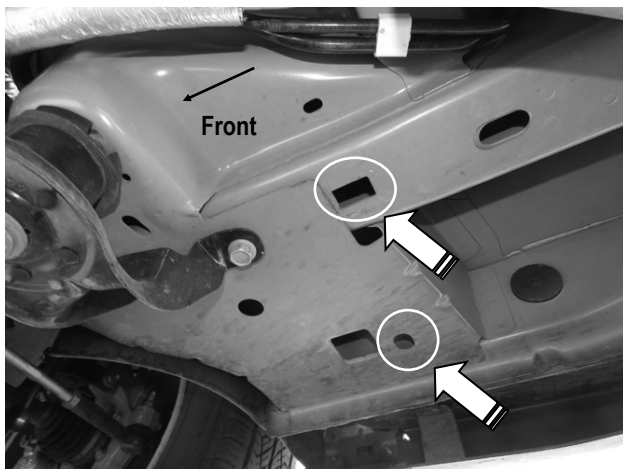

(Fig 1) Passenger Side Front Mounting Location

STEP 2

Select (2) M10 L Bolt Plates (2) M10 Plastic Washers. Partially thread the Plastic Washers onto the M10 L Bolt Plates. Insert the M10 L Bolt Plates with Plastic Washers into the front mounting holes, (**Fig 2**). Thread the Plastic Washer down tight against the floor panel. The Plastic Washer is designed to hold the Bolt Plate in place during Bracket installation.

NOTE: Hold the Passenger Front Mounting Bracket (PFM) up to the front mounting location to help determine the correct mounting holes.

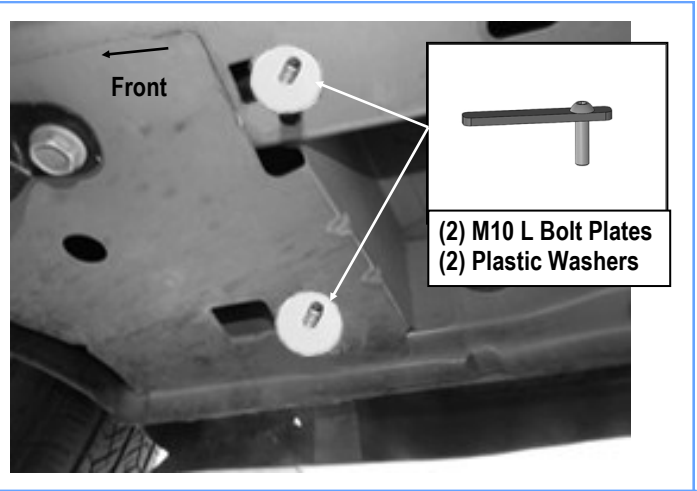

(Fig 2) M10 L Bolt Plates Installed
(On Passenger Side Front Mounting Location)

STEP 3

Attach the Passenger Front Mounting Bracket (PFM) to the installed (2) M10 L Bolt Plates with (2) M10 Flat Washers, (2) M10 Lock Washers and (2) M10 Hex Nuts, (**Fig 3 & 4**). Do not fully tighten hardware at this time.

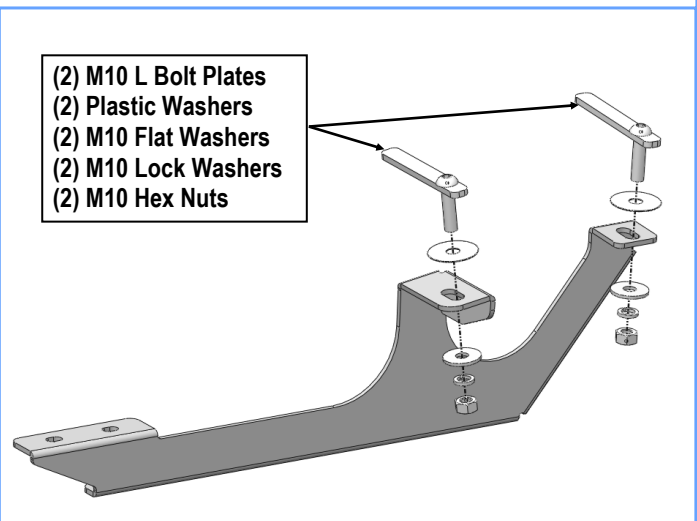

(Fig 3) Passenger Front Mounting Bracket Installation



(Fig 4) Passenger Front Mounting Bracket Installed

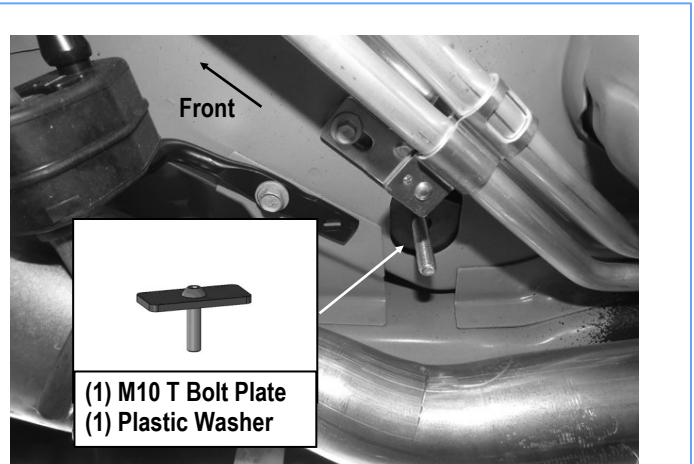

(Fig 6) M10 T Bolt Plate Installed
(On Passenger Side Center Mounting Location)

STEP 4

Move to the Passenger Side Center Mounting Location, (Fig 5). Locate the large slot above the passenger side exhaust pipe, (Fig 5).

Next, select (1) M10 T Bolt Plate and (1) Plastic Washer. Partially thread the Plastic Washer onto the M10 T Bolt Plate. Insert the M10 T Bolt Plate with Plastic Washer into the front mounting hole, (Fig 6). Thread the Plastic Washer down tight against the floor panel. The Plastic Washer is designed to hold the M10 T Bolt Plate in place during Bracket installation.

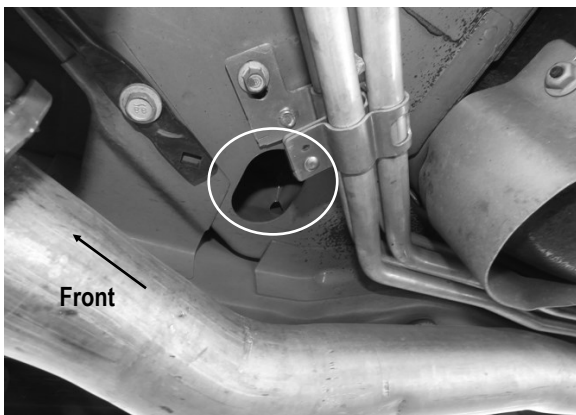

(Fig 5) Passenger Side Center Mounting Location

STEP 5

Attach the Passenger Center Mounting Bracket (PCM) to the installed M10 T Bolt Plate with (1) M10 Flat Washer, (1) M10 Lock Washer and (1) M10 Hex Nut, (Fig 7). Do not fully tighten hardware at this time.

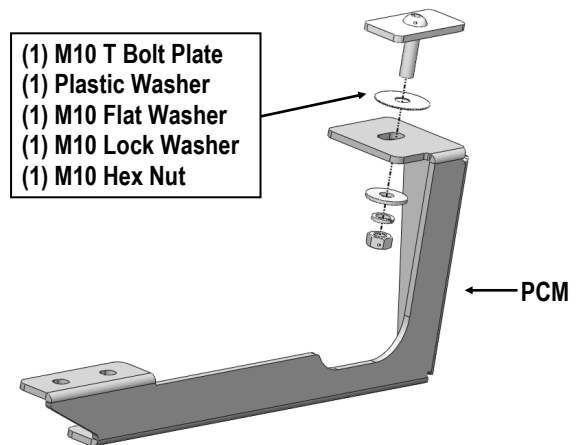

(Fig 7) Passenger Center Mounting Bracket (PCM) Installation



STEP 6

Move to the Passenger Side Rear Mounting Location, (Fig 8). Remove the (2) factory hex bolts (Fig 8).

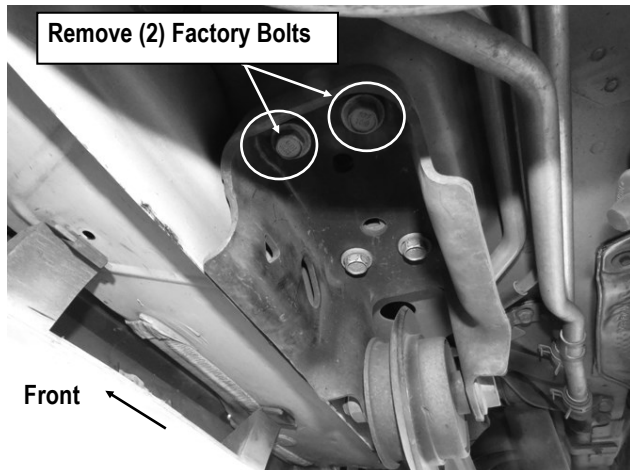

(Fig 8) Passenger Side Rear Mounting Location

STEP 7

Reuse the (2) factory hex bolts to attach the Passenger Rear Mounting Bracket (PRM) to the rear mounting location, (Fig 9). Do not fully tighten hardware at this time.

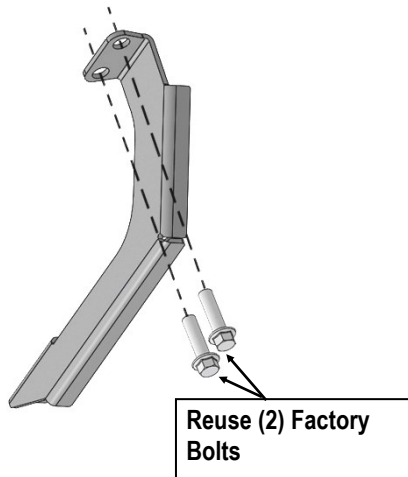

(Fig 9) Passenger Rear Mounting Bracket (PRM) Installation

STEP 8

Once all (3) Passenger side mounting brackets are installed, then proceed to the Step Bar installation. (Figs 10 & 11)

- (1) Select (1) Slider and (2) M8X1.25-35mm Carriage Bolts;
- (2) Install (2) M8X1.25-35mm Carriage Bolts in (1) Slider.
- (3) Slide the Slider (with carriage bolts) to the **Step Bar**.
- (4) Repeat to install the other (2) sliders to the step bar.
- (5) Attach the Step Bar (with the Sliders) onto the installed mounting brackets. Position the Sliders to the installed brackets. Secure the Step Bar to the installed Brackets by using (6) M8 Large Flat Washers and (6) M8 Nylon Lock Nuts and (3) Sliders, (Fig 11). Do not fully tighten hardware at this time.

Note: The Sliders are packed with the Step Bars.

Level and adjust the Step Bar and fully tighten all hardware.

STEP 9

Move to Driver side of the vehicle. Start installation from the driver side front of the vehicle. Repeat **Steps 1-3** for Driver Front Mounting Bracket (DFM) installation.

STEP 10

Move to the Driver Center Mounting Location, (Fig 12). Locate the large hole and remove the plastic plug coving the hole on the frame channel, (Fig 12). And then, Insert the remaining (1) M10 L Bolt Plate with (1) Plastic Washer and (1) M10 T Bolt Plate with (1) Plastic Washer into the holes, (Fig 12).

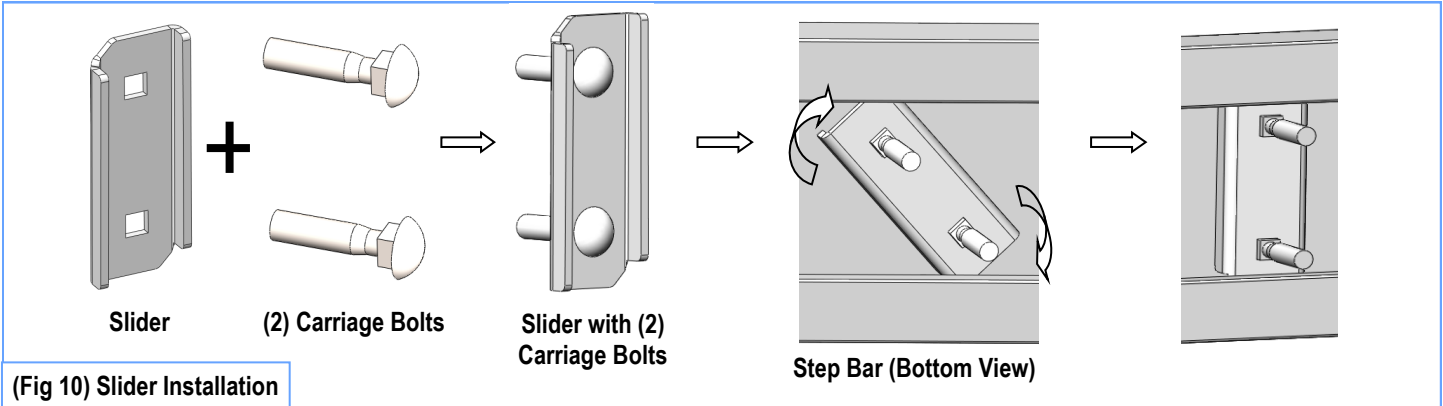

(Fig 10) Slider Installation

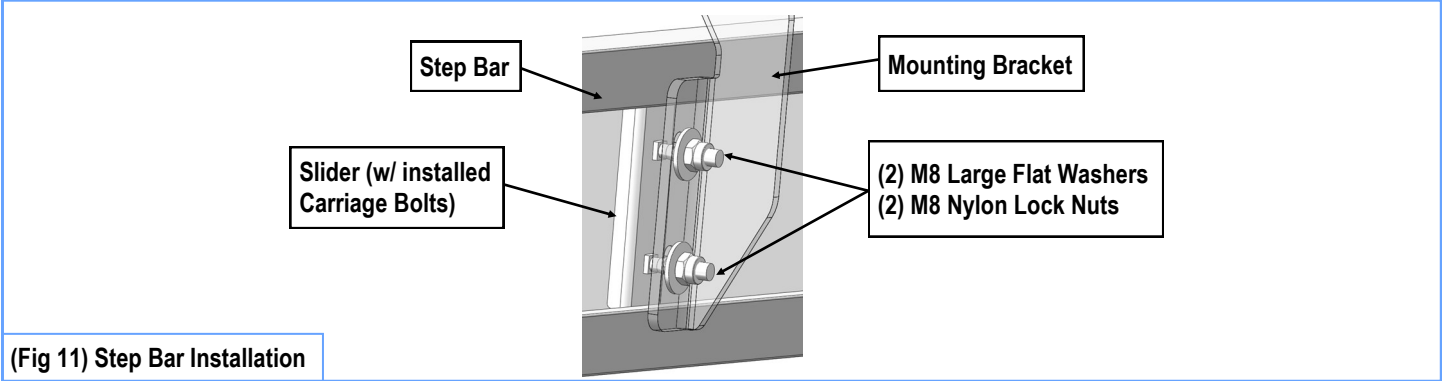

(Fig 11) Step Bar Installation

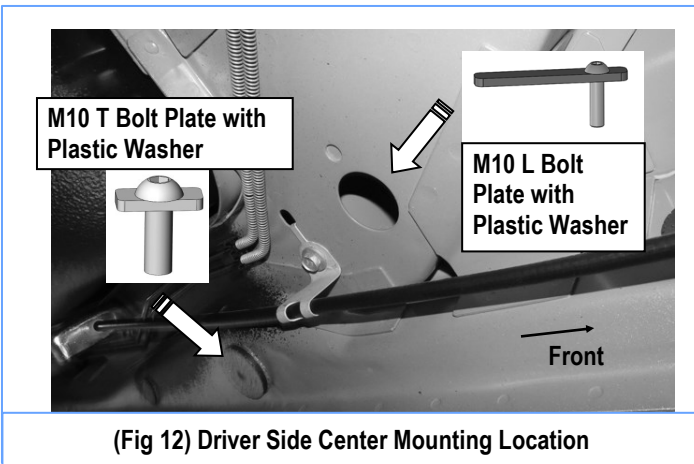

(Fig 12) Driver Side Center Mounting Location

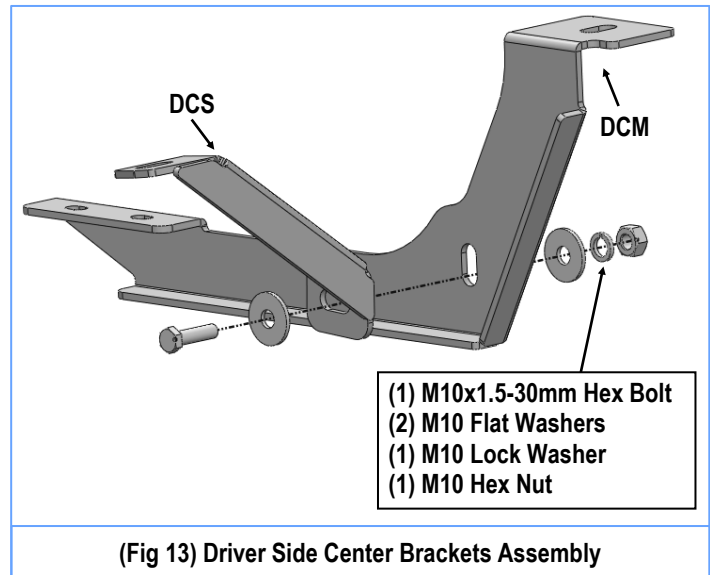

(Fig 13) Driver Side Center Brackets Assembly

STEP 11

Assemble Driver Center Mounting Bracket (**DCM**) and Driver Center Support Bracket (**DCS**) with (1) M10x1.5-30mm Hex Bolt, (2) M10 Flat Washers, (1) M10 Lock Washer and (1) M10 Hex Nut, (**Fig 13**). Do not fully tighten hardware at this time.



STEP 12

Next, repeat **Steps 4-5** to install the assembled Driver Center Mounting Bracket (**DCM**) to the installed M10 L Bolt Plate, (**Fig 14**). Attach the Driver Center Support Bracket (**DCS**) to the installed M10 T Bolt Plate with (1) M10 Flat Washer, (1) M10 Lock Washer and (1) M10 x 1.5 Hex Nut, (**Fig 14**). Do not fully tighten hardware at this time.

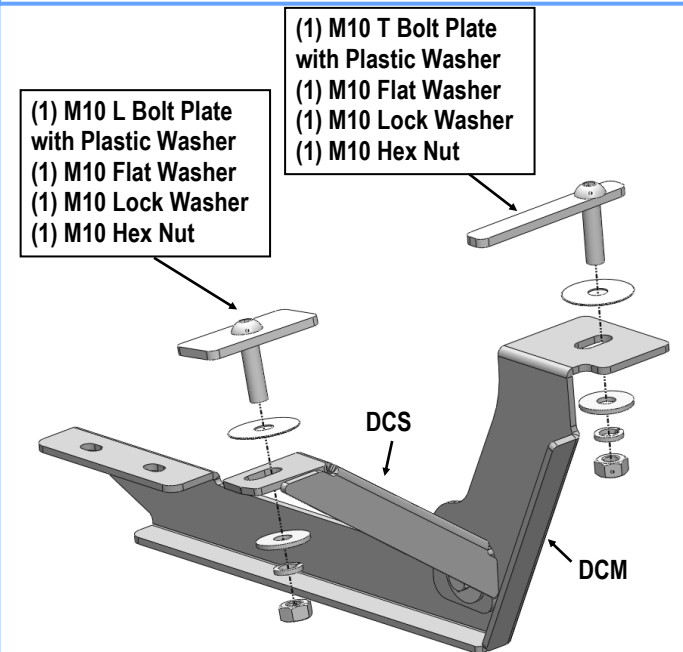

(Fig 14) Driver Side Center Brackets Installed

STEP 13

Repeat **Steps 6-7** for Driver Rear Mounting Bracket (**DRM**) installation.

STEP 14

Repeat **Steps 8-10** for driver side Step Bar installation. **The installation is completed.**

Attention

Do periodic inspections to the installation to make sure that all hardware is secure and tight.

In order to protect your bars/boards, please use mild soap/non-abrasive products for cleaning only.