

# iBoard®



Scan for  
Installation Video

## iBoard® by APS

PART#: IB-252C&H

READ INSTRUCTIONS CAREFULLY BEFORE STARTING INSTALLATION. REMOVE CONTENTS FROM BOX AND VERIFY ALL PARTS ARE PRESENT. ASSISTANCE IS RECOMMENDED.

\*ROCKER PANEL MOUNT  
\*NO DRILLING REQUIRED

Fastener Size	Tightening Torque (ft-lbs)	Required
6mm	6-7	√
8mm	16-18	√
10mm	31-32	√
12mm	56-58	X
14mm	92-94	X

### PART LIST

Driver Side Step Bar

Front

Passenger Side Step Bar

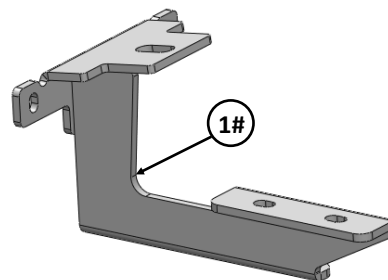
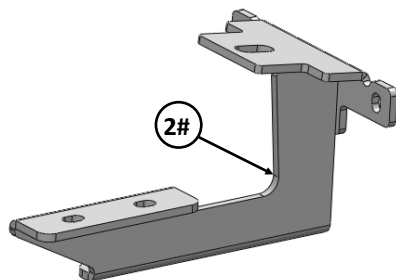
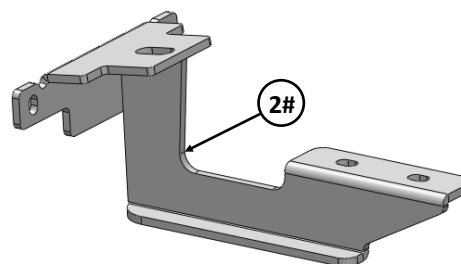
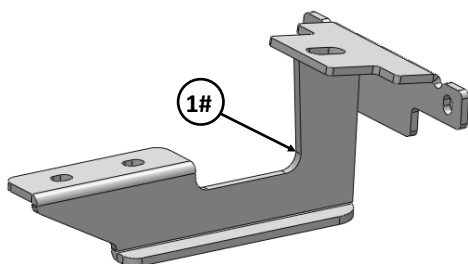
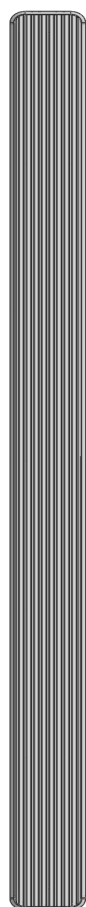

Customer Support: [info@iboardauto.com](mailto:info@iboardauto.com)



Mounting Bracket List					
Item	QTY	Description	Item	QTY	Description
1#	2	Driver Front / Passenger Rear Mounting Brackets	2#	2	Passenger Front / Driver Rear Mounting Brackets

Hardware Package A (For Bracket Installation)					
Item	QTY	Description	Item	QTY	Description
1#	4	M10 Bolt Plates	5#	8	M6X1-25mm Hex Bolts
2#	4	M10 Plastic Washers	6#	8	M6 Large Flat Washers
3#	4	M10 Flat Washers	7#	8	M6 Flat Washers
4#	4	M10X1.5 Hex Flange Nuts	8#	8	M6X1 Nylon Lock Nuts

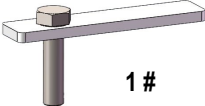

1 #



2 #



3 #



4 #

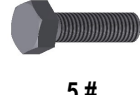

5 #



6 #



7 #



8 #

Hardware Package B (For Stainless Steel Step Bar Installation)					
Item	QTY	Description	Item	QTY	Description
1#	8	M8X1.25-35mm Carriage Bolts	3#	8	M8 Nylon Lock Nuts
2#	8	M8 Large Flat Washers	4#	4	Sliders (Packed with Step Bars)

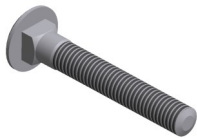

1 #



2 #



3 #

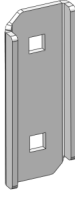

4 #



## STEP 1

Starting at the driver side, locate the (2) pairs of factory holes on the pinch weld, **(Fig 1 & 2)**. Remove the rubber plug covering the oval hole at the bottom of the rocker panel, **(Fig 3)**.

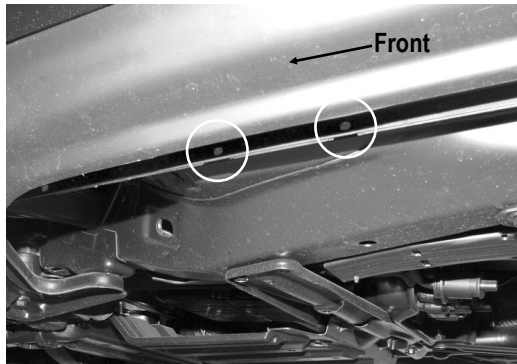

**(Fig 1) Driver Side Front Mounting Location**

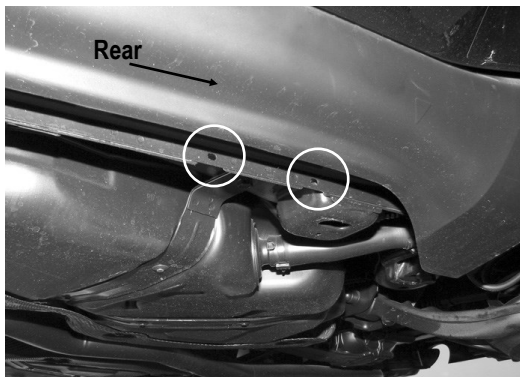

**(Fig 2) Driver Side Rear Mounting Location**

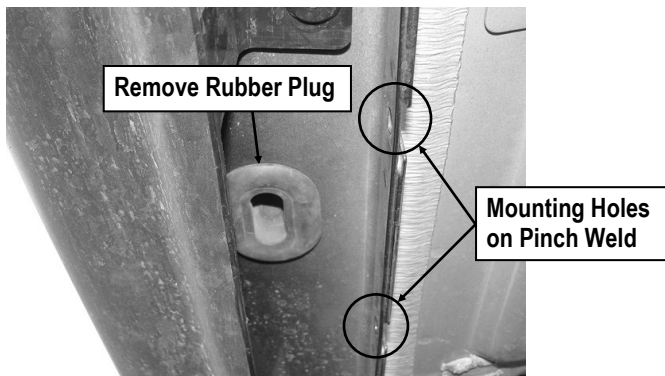

**(Fig 3) Driver Side Front Mounting Location**

## STEP 2

Select (1) M10 Bolt Plate and (1) M10 Plastic Washer. Partially thread the M10 Plastic Washer onto the Welded Bolt. Insert the M10 Bolt Plate into the oval hole and rotate across the slot, **(Fig 4)**. Thread the M10 Plastic Washer all the way down the Welded Bolt and tight against the body panel.

**NOTE:** The M10 Plastic Washer is designed to prevent the Bolt Plate from falling into the body panel and hold the bolt plate in place within the bracket installation.

After inserting, rotate M10 Bolt Plate across the slot or until M10 Bolt Plate stopped.

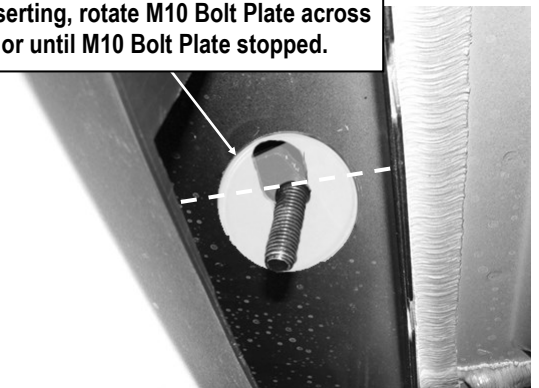

**(Fig 4) M10 Bolt Plate Installed  
(on Driver Side Front Mounting Location)**

## STEP 3

Attach the Driver Front Mounting Bracket to the installed M10 Bolt Plate with (1) M10 Flat Washer and (1) M10x1.5 Hex Flange Nut, **(Figs 5-7)**.

Line up the (2) small slots on the Driver Front Mounting Bracket with the (2) holes on the pinch weld. Bolt the Driver Front Mounting Bracket to the outside of the pinch weld with (2) M6x1-25mm Hex Bolts, (2) M6 Large Flat Washers (outside against Bracket) , (2) M6 Flat Washers (inside against pinch weld) and (2) M6x1 Nylon Lock Nuts, **(Figs 5 –7)**. Do not fully tighten hardware at this time.

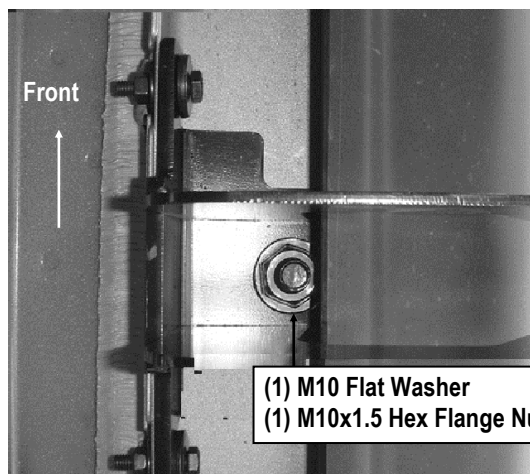

(Fig 5) Driver Front Mounting Bracket Installation

- (2) M6x1-25mm Hex Bolts
- (2) M6 Large Flat Washer (outside)
- (2) M6 Flat Washer (inside)
- (2) M6x1 Nylon Lock Nuts

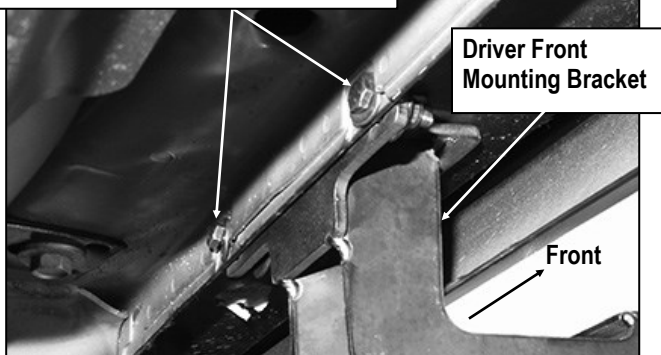

(Fig 6) Driver Front Mounting Bracket Installation

## STEP 4

Repeat **Steps 2-3** to install the Driver Rear Mounting Bracket. Do not fully tighten hardware at this time.

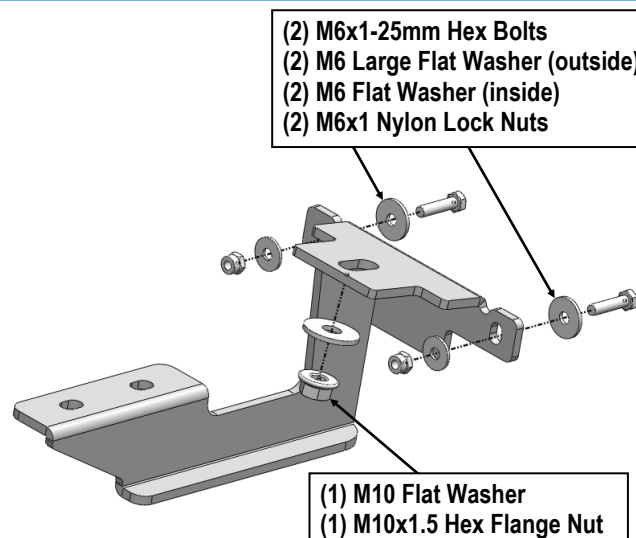

(Fig 7) Driver Front Mounting Bracket Installation

## STEP 5

Once all (2) Driver side mounting brackets are installed, then proceed to the Step Bar installation. (**Figs 8 & 9**)

- (1) Select (1) Slider and (2) M8X1.25-35mm Carriage Bolts;
- (2) Install (2) M8X1.25-35mm Carriage Bolts in (1) Slider.
- (3) Slide the Slider (with carriage bolts) to the **Step Bar**.
- (4) Repeat to install the other (1) slider to the step bar.
- (5) Attach the Step Bar (with the Sliders) onto the installed mounting brackets. Position the Sliders to the installed brackets. Secure the Step Bar to the installed Brackets by using (4) M8 Large Flat Washers and (4) M8 Nylon Lock Nuts and (2) Sliders, (**Fig 9**). Do not fully tighten hardware at this time.

**Note:** The Sliders are packed with the Step Bars.

Level and adjust the Step Bar and fully tighten all hardware.

Repeat **Steps 1-5** for the other side Step Bar installation. **The installation is completed!!!**

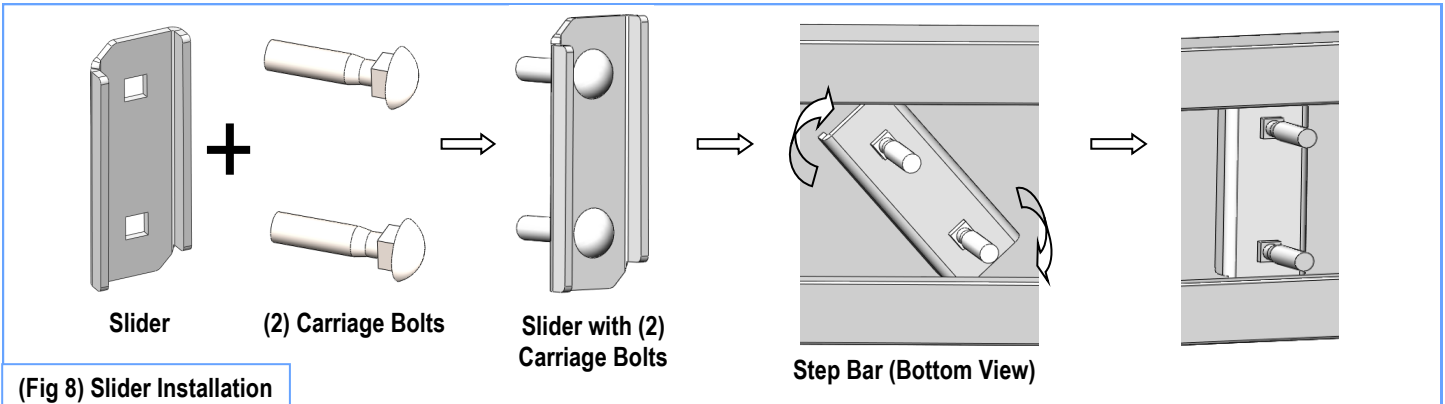

(Fig 8) Slider Installation

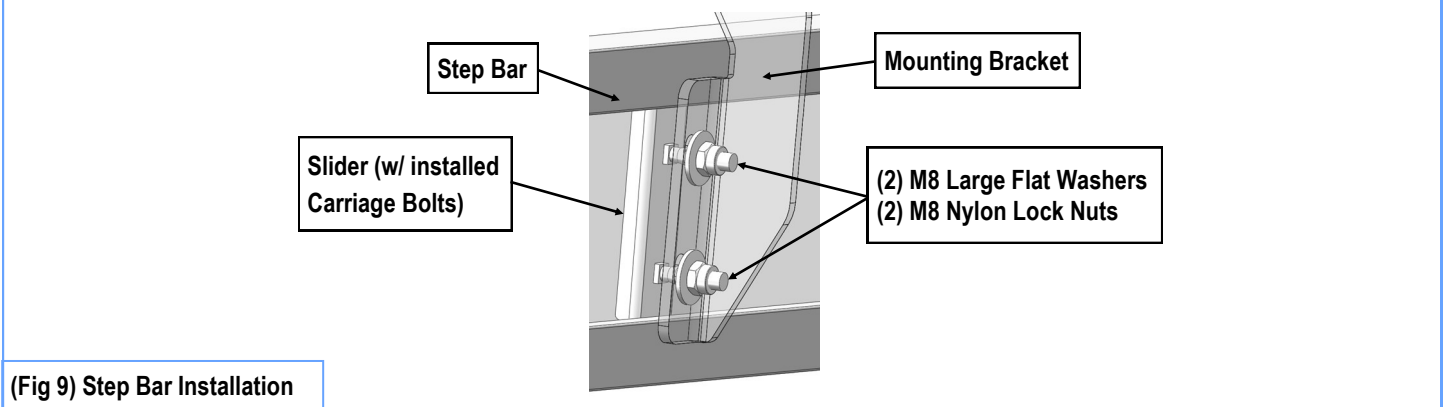

(Fig 9) Step Bar Installation

### Attention

Do periodic inspections to the installation to make sure that all hardware is secure and tight.  
In order to protect your bars/boards, please use mild soap/non-abrasive products for cleaning only.