

iBoard®

iBoard® by APS

PART#: IB-048

READ INSTRUCTIONS CAREFULLY BEFORE STARTING INSTALLATION. REMOVE CONTENTS FROM BOX AND VERIFY ALL PARTS ARE PRESENT. ASSISTANCE IS RECOMMENDED.

*ROCKER PANEL MOUNT
*NO DRILLING REQUIRED

Fastener Size	Tightening Torque (ft-lbs)	Required
6mm	6-7	√
8mm	16-18	√
10mm	31-32	√
12mm	56-58	√
14mm	92-94	X

PART LIST

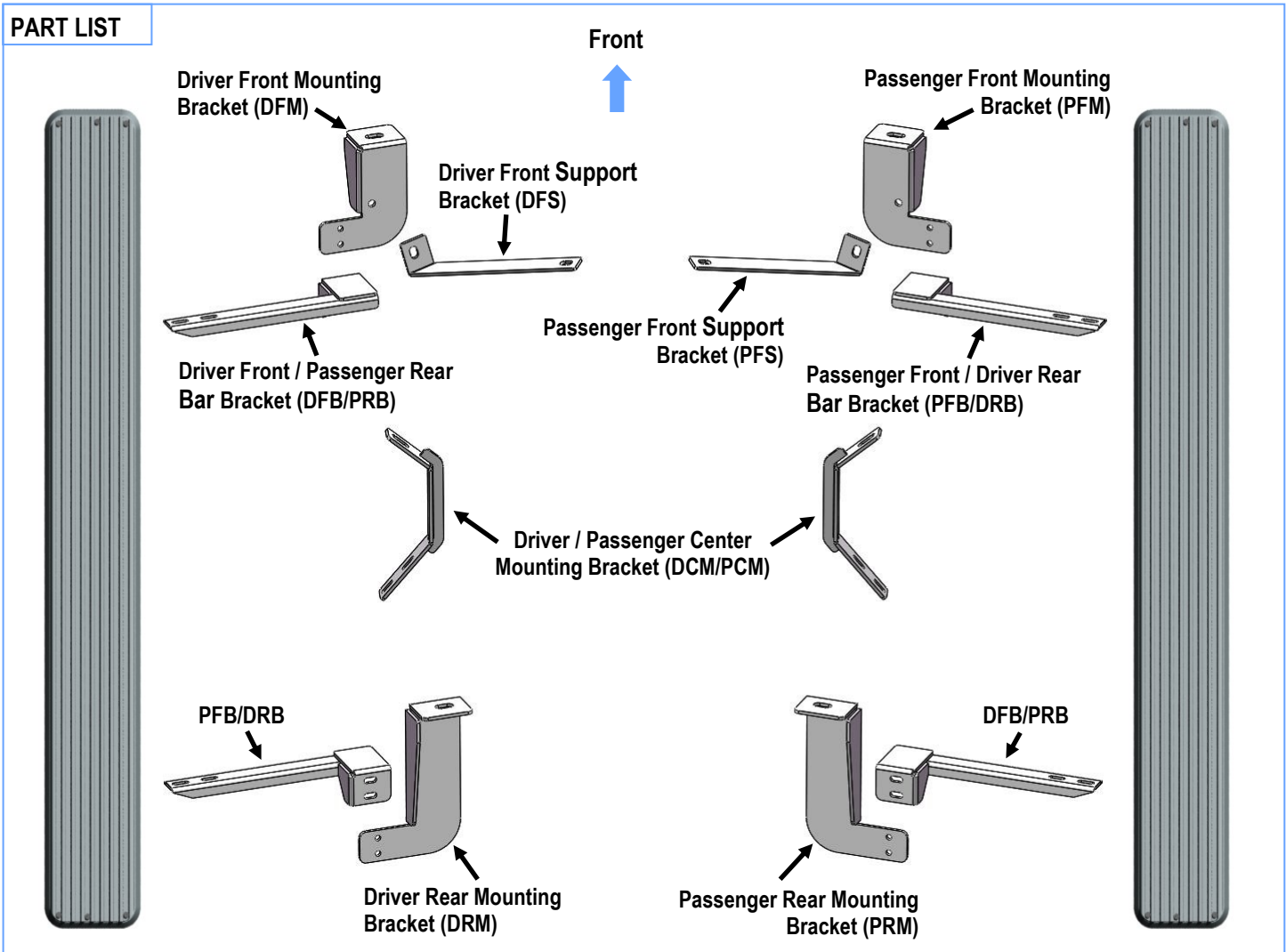

Customer Support: info@iboardauto.com

iBoard®

Hardware Package A (For Bracket Installation)

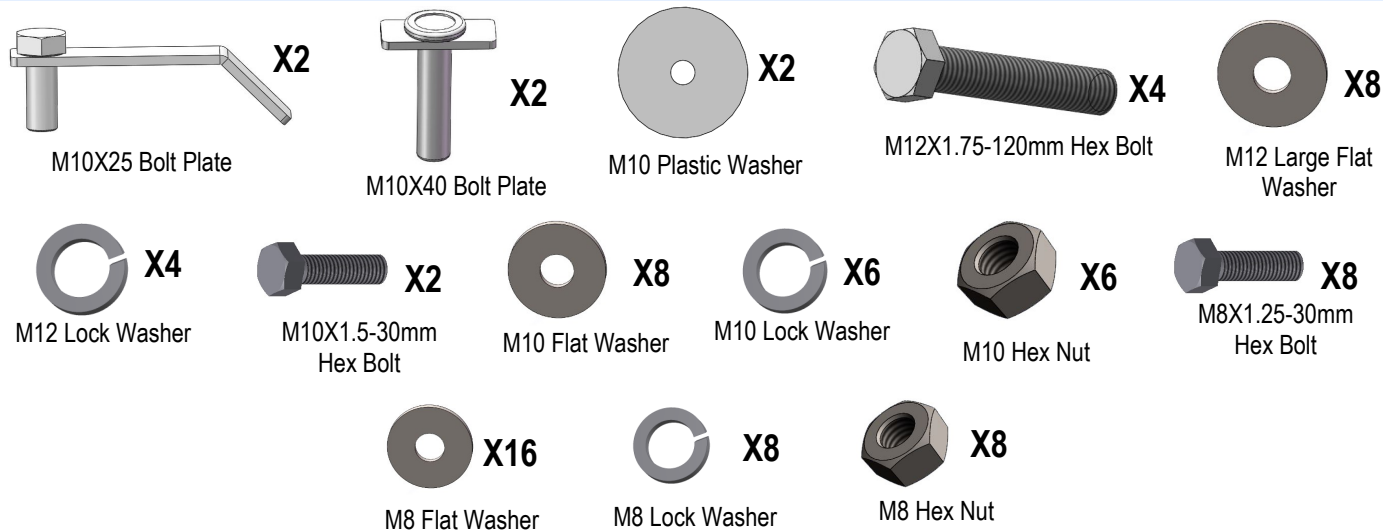

Hardware Package B (For Aluminum Step Bar Installation Only, Not Supply to Stainless Steel Step Bar)



Hardware Package C (For Stainless Steel Step Bar Installation Only, Not Supply to Aluminum Step Bar)



STEP 1

Start the installation from the passenger side of the vehicle. Remove the passenger side front body mount bolts.

STEP 2

Select the Passenger Front Mounting Bracket (**PFM**). Insert (1) M12X1.75-120mm Hex Bolt with (1) M12 Large Flat Washer and (1) M12 Lock Washer through the Mounting Bracket. Place (1) M12 Large Flat Washer onto the Bolt, then slide the rubber bushing onto the Hex Bolt against the Washer. Make sure that the M12 Large Flat Washer is between the Bracket and the factory rubber bushing, (**Fig 1A**).

iBoard®

Hold the Bracket and hardware up in place and attach to the factory body mount. Do not tighten hardware at this time.
IMPORTANT: Depending on model year, the M12 Large Flat Washer on the factory body mount bolt may be removable, (do not discard-must reinstall), and the bolt is long enough to go through the Mounting Bracket and properly thread into the body mount. It is the installer's responsibility to check length and to determine whether to reuse the factory body bolt or the included replacement M12X1.75-120mm Hex Bolt, (Fig 1B).

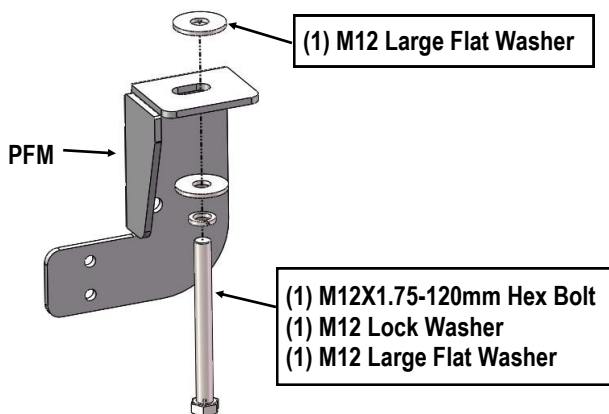

(Fig 1A) Passenger Side Front Mounting Bracket Installed

(1) M12X1.75-120mm Hex Bolt
(1) M12 Lock Washer
(1) M12 Large Flat Washer
(or use factory hardware)



(Fig 1B) Passenger Side Front Mounting Bracket Installed (example only)

STEP 3

Insert (1) M10X40 Bolt Plate into the slotted hole in the bottom of frame rail located near the front body mount, (Fig 2).

Select the Passenger Front Support Bracket (PFS) and hang it to the installed M10X40 Bolt Plate with the included (1) M10 Flat Washer, (1) M10 Lock Washer and (1) M10 Hex Nut, (Fig 3). Do not fully tighten hardware at this time.

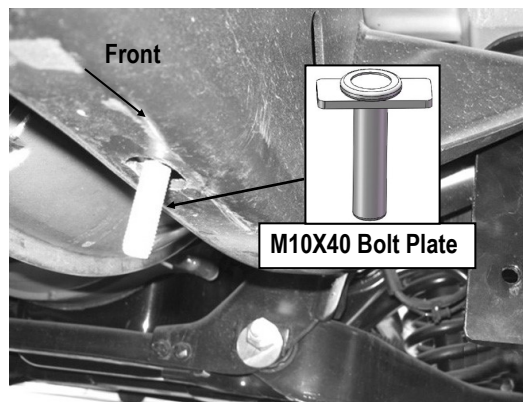

(Fig 2) Insert (1) M10X25 Bolt Plate

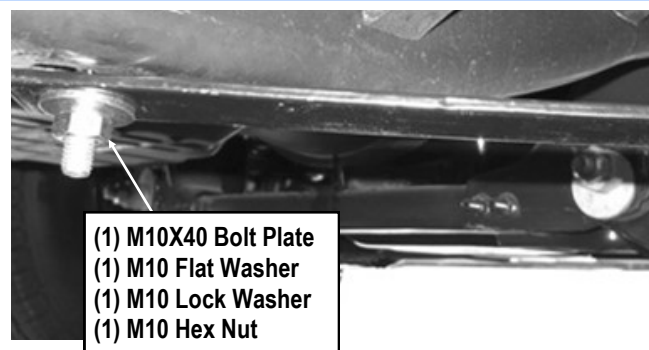

(Fig 3) Passenger Front Support Bracket Installation

STEP 4

Attach the opposite end of the Support Bracket to the mounting hole on the side of the Passenger Front Mounting Bracket using the included (1) M10X1.5-30mm Hex Bolt, (2) M10 Flat Washer, (1) M10 Lock Washer and (1) M10 Hex Nut, (Fig 4). Do not fully tighten hardware at this time.

iBoard®

Select the Passenger Front Bar Bracket (**PFB/DRB**) and attach the bracket to the Passenger Front Mounting Bracket with (2) M8X1.25-30mm Hex Bolts, (4) M8 Flat Washers, (2) M8 Lock Washers and (2) M8 Hex Nuts, (**Fig 4**). Do not fully tighten hardware at this time.

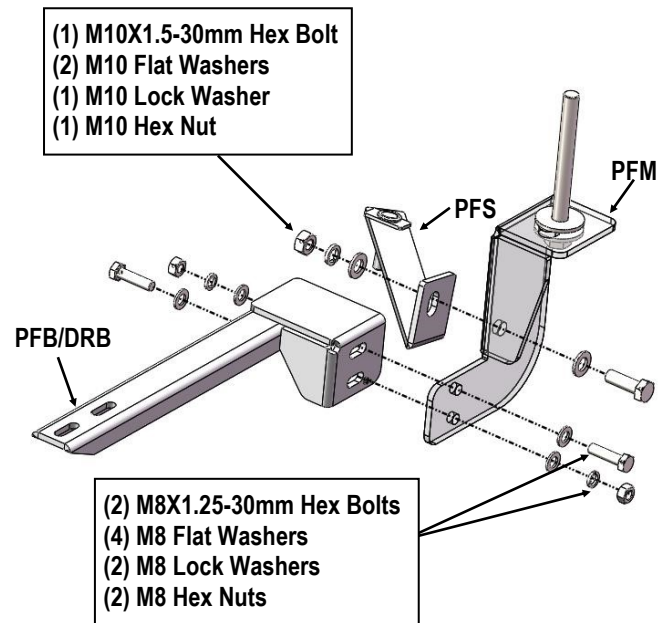

(Fig 4) Passenger Side Front Brackets Assembly

STEP 5

Move to the passenger side center location. Locate the holes in the side panel (remove sealing tape as necessary) for the Passenger Center Mounting Bracket, (typically one slot and two round holes).

Insert (1) M10X25 Bolt Plate with (1) M10 Plastic Washer into the slotted hole and exit the M10X25 Bolt Plate through the round hole, (**Figs 5 & 6**). **NOTE:** Some vehicles may have several holes in the side panel. To determine the correct mounting location, position the Passenger Center Mounting Bracket up and attach to the threaded insert.

Attach the Passenger Center Mounting Bracket (**DCM/PCM**) with (1) M10 Flat Washer, (1) M10 Lock Washer and (1) M10 Hex Nut, (**Fig 7**). Do not fully tighten hardware at this time.

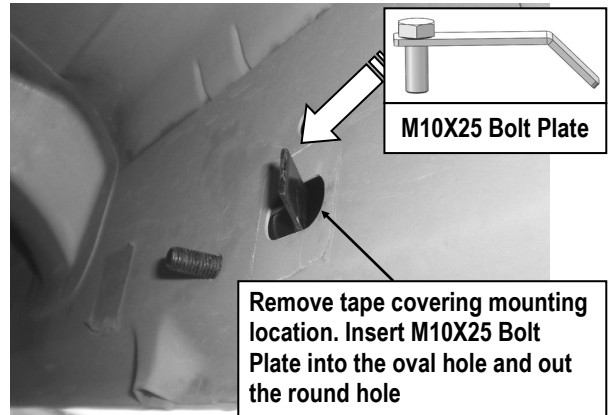

(Fig 5) Passenger Side Front Mounting Location

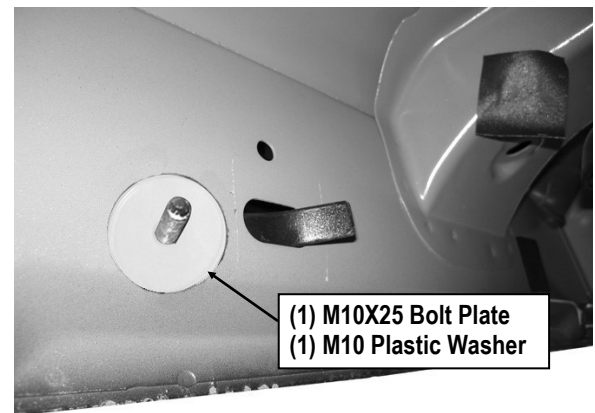

(Fig 6) Insert (1) M10X25 Bolt Plate With (1) M10 Plastic Washer

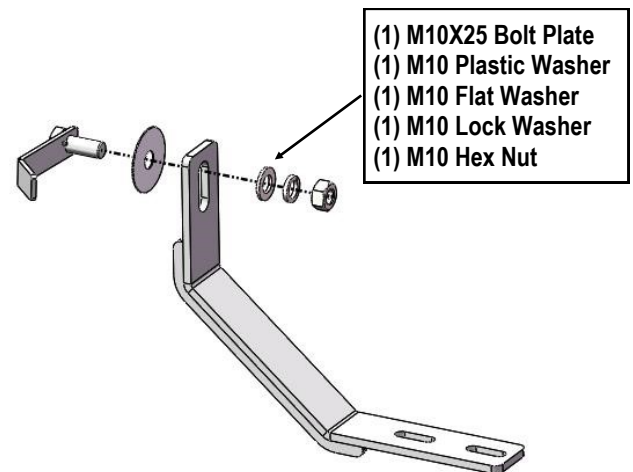

(Fig 7) Passenger Side Center Mounting Bracket Installed

iBoard®

STEP 6

Move to the passenger side rear mounting location (at the back of the cab). Select the Passenger Rear Mounting Bracket (PRM) and (1) M12 Large Flat Washer. Repeat **Steps 1—2** for Passenger Rear Mounting Bracket installation, (Fig 8).

Select the Passenger Rear Bar Bracket (DFB/PRB), repeat **Steps 4** for Passenger Rear Bar Bracket installation, (Fig 8). Do not fully tighten hardware at this time.

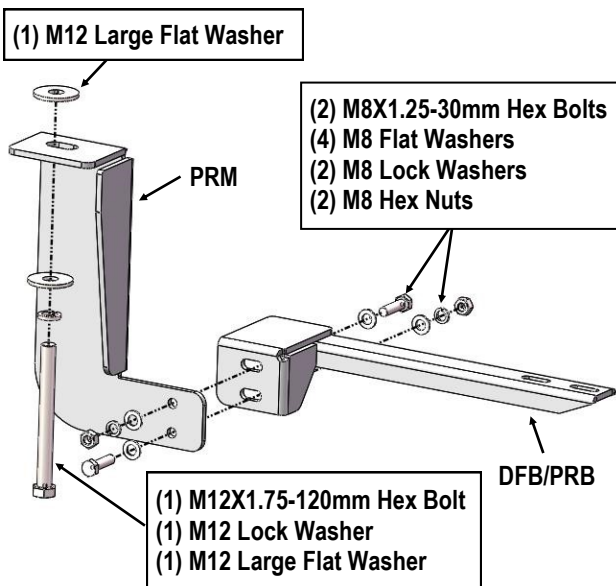

(Fig 8) Passenger Side Rear Brackets Assembly

STEP 7

Once all (3) mounting brackets are installed, then proceed to the Step Bar installation. According to the style of Step Bar proceed to the correct installation STEPS.

Note: Aluminum Step Bar refer to STEP 8; Stainless Steel Step Bar skip to STEP 9.

STEP 8

Aluminum Step Bar Installation:

Select a **Aluminum Step Bar**. Slip (3) M6x1-20mm Square Head Bolts into each bottom channel (Fig 9). Carefully position the Step Bar onto the (3) Mounting Brackets.

IMPORTANT: Do not slide the Step Bar on the Brackets or the bottom surface of the board will be damaged. Attach the Step Bar to each Mounting Brackets with (2) M6x1-20mm Square Head Bolts, (2) M6 Large Flat Washers and (2) M6 Nylon Lock Nuts, (Fig 10). Do not fully tighten at this time.

Level and adjust the Step Bar and fully tighten all hardware. Repeat **Steps 1-8** for the other side Step Bar installation. **The installation is completed!!!**



(Fig 9) Slip M6X1-20mm Square Head Bolts Into The Bottom Channels

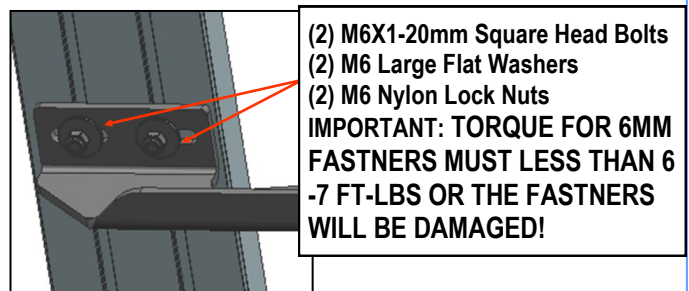

(Fig 10) Running Board Installed Onto Mounting Bracket

iBoard®

STEP 9

Stainless Steel Step Bar Installation:

Select a **Stainless Steel Step Bar** (with the U-Sliders installed on the Bar). Loose the U-Sliders, reposition the U-Sliders onto the board according to the (3) Installed Mounting Brackets location, (**Fig 11**). Re-secure the U-Sliders on the Step Bar. Attach the Step Bar to the installed Mounting Brackets with (6) M6X1-20mm Hex Bolts, (6) M6 Large Flat Washers & (6) M6 Lock Washers, (**Fig 12**). Do not fully tighten hardware at this time. Level and adjust the Step Bar and fully tighten all hardware. Repeat **Steps 1-7 and 9** for the other side Step Bar installation. **The installation is completed!!!**



(Fig 11) Slide & line up the U-Slider with the installed mounting brackets along bottom channel

- (2) M6X1-20mm Hex Bolts
- (2) M6 Large Flat Washers
- (2) M6 Lock Washers

IMPORTANT: TORQUE FOR 6MM FASTNERS MUST LESS THAN 6-7 FT-LBS OR THE FASTNERS WILL BE DAMAGED!

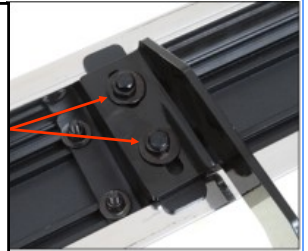

(Fig 12) Step Bar Installed on Bracket Installed (Example)

Attention

Do periodic inspections to the installation to make sure that all hardware is secure and tight.

In order to protect your bars/boards, please use only mild soap/non-abrasive products for cleaning.